

|| JAI SRI GURUDEV ||



Sri Adichunchanagiri Shikshana  
Trust[R]

**S J C INSTITUTE OF TECHNOLOGY**

**CHICKBALLAPUR – 562101**

**DEPARTMENT OF ELECTRONICS &  
COMMUNICATION ENGINEERING**

**COMMUNICATION LAB MANUAL (18ECL67)  
VI SEMESTER**

**PREPARED BY**

**Dr. B.N. Shobha**, Professor &  
Head

**Nirmala Devi A C**, Assistant  
Professor

**Veena S**, Assistant Professor

# **S J C INSTITUTE OF TECHNOLOGY**

## **VISION OF THE INSTITUTE**

S.J.C.I.T is committed to Quality Education, Training and Research.

## **MISSION OF THE INSTITUTE**

- Augmenting the supply of competent Engineers and Managers
- Building Engineers and Managers with Value, Vision and Versatility
- Developing and dissemination of new Knowledge and Insights

## **DEPARTMENT OF ELECTRONICS & COMMUNICATION**

### **ENGINEERING VISION OF DEPARTMENT**

To Achieve Academic Excellence in Electronics and Communication Engineering by Imparting quality Technical Education and facilitating Research Activities

### **MISSION OF DEPARTMENT**

- Establishing State of the Art Laboratory facilities and Infrastructure to develop the spirit of Innovation and Entrepreneurship
- Nurturing the Students with Technical Expertise along with Professional Ethics to provide solutions for Societal Needs
- Encourage Life Long Learning And Research among the Students and Faculty

### **PROGRAM EDUCATIONAL OBJECTIVES**

After successful completion of the program, the Graduates of the program will :

**PEO1:** Have successful technical and professional career in Engineering, Technology and multidisciplinary environments.

**PEO2:** Utilize their knowledge, technical and communication Skills to propose optimal solutions to problems related to society in the field of Electronics and Communication.

**PEO3:** Exhibit good interpersonal skills, leadership qualities and adapt themselves for lifelong learning.

**PROGRAM SPECIFIC OUTCOMES**

**PSO1: Professional Skills:** Ability to absorb and apply fundamental knowledge of core Electronics and Communication Engineering in the analysis, design and development of Electronics Systems as well as to interpret and synthesize experimental data leading to valid conclusions

**PSO2: Problem-solving skills:** Ability to solve complex Electronics and Communication Engineering problems, using latest hardware and software tools, along with analytical and managerial skills to arrive at appropriate solutions, either independently or in team

**TABLE OF CONTENTS**

<b>Experiment No</b>	<b>PART-A</b>	<b>Page. No</b>
i.	COURSE SYLLABUS	<b>5</b>
1.	Amplitude Modulation And Demodulation	6-10
2.	Frequency Modulation And Demodulation	11-12
3.	Pulse Sampling, Flat Top Sampling	13-15
4.	TDM	16-17
5.	FSK And PSK	18-22
6.	Micro Wave Test Bench	23-25
7.	Radiation Pattern Of Yagi Antenna	26-30
8.	Characteristics Of Micro Strip Directional Coupler, Ring Resonator And Power Divider	31-38
<b>PART-B</b>		
1.	Simulate NRZ, RZ, half-sinusoid and raised cosine pulses and generate eye diagram for binary polar signaling.	40-46
2.	Simulate the Pulse code modulation and demodulation system and display the waveforms.	47-49
3.	ComputationsoftheProbabilityofbiterrorforcoherentbinaryASKFSKand PSK for an AWGN Channel and Compare them with their Performance curves.	50
4.	Digital Modulation schemes: DPSK Transmitter and Receiver.	51
5.	Digital Modulation schemes: DPSK Transmitter and Receiver.	52

## Course syllabus

### **PART-A: Experiments No. 1 to 5 has to be performed using discrete components.**

1. Amplitude Modulation and Demodulation: i) Standard AM, ii) DSBSC (LM741 and LF398 ICs can be used)
2. Frequency modulation and demodulation ( IC 8038/2206 can be used)
3. Pulse sampling, flat top sampling and reconstruction
4. Time Division Multiplexing and Demultiplexing of two band limited signals.
5. FSK and PSK generation and detection
6. Measurement of frequency, guide wavelength, power, VSWR and attenuation in microwave test bench.
7. Obtain the Radiation Pattern and Measurement of directivity and gain of micro strip dipole and Yagi antennas.
8. Determination of
  - a. Coupling and isolation characteristics of microstrip directional coupler.
  - b. Resonance characteristics of microstrip ring resonator and computation of dielectric constant of the substrate.
  - c. Power division and isolation of microstrip power divider.

### **PART-B: Simulation Experiments using SCILAB/MATLAB/Simulink or LabVIEW**

1. Simulate NRZ, RZ, half-sinusoid and raised cosine pulses and generate eye diagram for binary polar signaling.
2. Pulse code modulation and demodulation system.
3. Computations of the Probability of bit error for coherent binary ASK, FSK and PSK for an AWGN Channel and Compare them with their Performance curves.
4. Digital Modulation Schemes i) DPSK Transmitter and receiver, ii) QPSK Transmitter and Receiver.

### **Course Outcomes:**

<b>C315.1</b>	Determine the characteristics and response of microwave waveguide.
<b>C315.2</b>	Determine the characteristics of microstrip antennas and devices and compute the parameters associated with it.
<b>C315.3</b>	Design and test the digital and analog modulation circuits and display the waveforms.
<b>C315.4</b>	Simulate the digital modulation systems and compare the error performance of basic digital modulation schemes.

<b>EXPT. NO: 1.</b>	<b>AMPLITUDE MODULATION AND DEMODULATION</b>
---------------------	--

**AIM:**

- To generate amplitude modulated wave and determine the percentage modulation.
- To demodulate the modulated wave using envelope detector.

**Apparatus Required:**

Name of the Component/Equipment	Specifications/Range	Quantity
Transistor(BC 107)	$f_T = 300 \text{ MHz}$ $P_d = 1 \text{ W}$ $I_{c(\text{max})} = 100 \text{ mA}$	1
Diode(0A79)	Max Current 35mA	1
Resistors	1K , 2K , 6.8K , 10K	1 each
Capacitor	0.01 F	1
Inductor	130mH	1
CRO	20MHz	1
Function Generator	1MHz	2
Regulated Power Supply	0-30V, 1A	1

**Theory:** Amplitude modulation (AM) is a modulation technique used in electronic communication, most commonly for transmitting information via a radio carrier wave. In amplitude modulation, the amplitude (signal strength) of the carrier wave is varied in proportion to the waveform being transmitted. For instance the waveform may correspond to the sounds to be reproduced by a loudspeaker, or the light intensity of television pixels. This technique contrasts with frequency modulation, in which the frequency of the carrier signal is varied and phase modulation, in which its phase is varied.

One disadvantage of all amplitude modulation techniques (not only standard AM) is that the receiver amplifies and detects noise and electromagnetic interference in equal proportion to the signal. Increasing the received signal to noise ratio, say, by a factor

of 10 (a 10 decibel improvement), thus would require increasing the transmitter power by a factor of 10.

This is in contrast to frequency modulation (FM) and digital radio where the effect of such noise following demodulation is strongly reduced so long as the received signal is well above the threshold for reception.

For this reason AM broadcast is not favored for music and high fidelity broadcasting, but rather for voice communications and broadcasts (sports, news, talk radio etc.). Another disadvantage of AM is that it is inefficient in power usage; at least two-thirds of the power is concentrated in the carrier signal. The carrier signal contains none of the original information being transmitted (voice, video, data, etc.). However its presence provides a simple means of demodulation using envelope detection, providing a frequency and phase reference to extract the modulation from the sidebands. In some modulation systems based on AM, a lower transmitter power is required through The demodulation circuit is used to recover the message signal from the incoming AM wave at the receiver. An envelope detector is a simple and yet highly effective device that is well suited for the demodulation of AM wave, for which the percentage modulation is less than 100%. Ideally, an envelop detector produces an output signal that follows the envelop of the input signal wave form exactly; hence, the name. Some version of this circuit is used in almost all commercial AM radio receivers.

**Circuit Diagram: Amplitude Modulator and Demodulator**

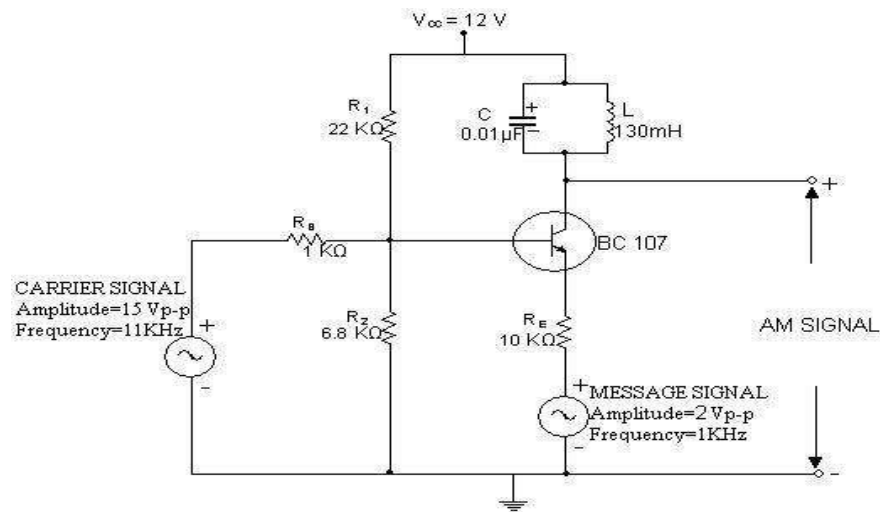

Fig.1. AM modulator

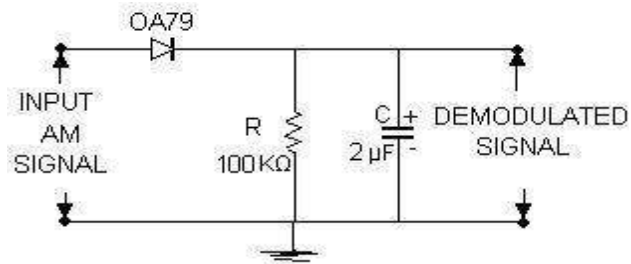
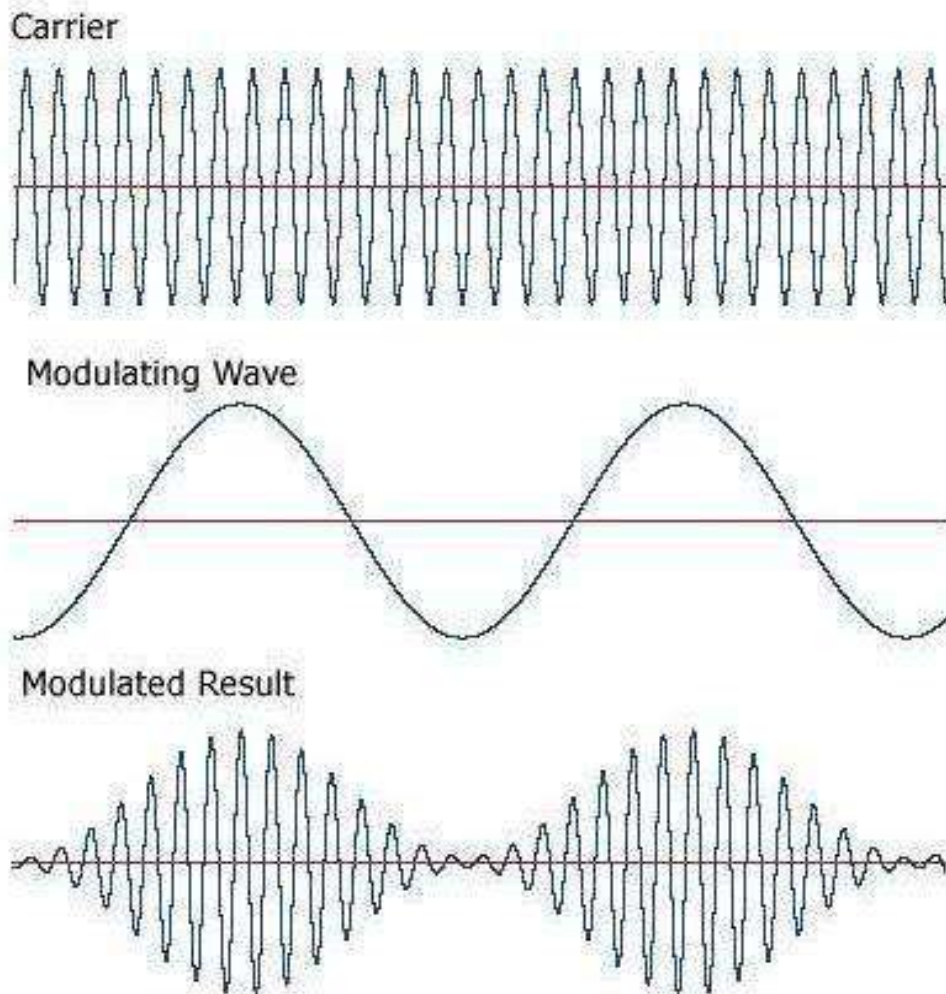

Fig.2. AM demodulator

**Ideal Waveforms:**

**Transfer Characteristic Curve :**



The Modulation Index is defined  
as,  $m =$

$$\frac{(E_{\max} - E_{\min})}{(E_{\max} + E_{\min})}$$

Where  $E_{\max}$  and  $E_{\min}$  are the  
maximum and minimum amplitudes of  
the modulated wave.

---

**Procedure :**

1. The circuit is connected as per the circuit diagram shown in Fig.1.
2. Switch on + 12 volts  $V_{cc}$  supply.
3. Apply sinusoidal signal of 1 KHz frequency and amplitude 2 Vp-p as modulating signal, and carrier signal of frequency 11 KHz and amplitude 15 Vp-p.
4. Now slowly increase the amplitude of the modulating signal up to 7V and note down values of  $E_{max}$  and  $E_{min}$ .
5. Calculate modulation index using equation
6. Repeat step 5 by varying frequency of the modulating signal.
7. Plot the graphs: Modulation index vs Amplitude & Frequency
8. Find the value of R from  $f_m \approx \frac{1}{2RC}$  taking C = 0.01
9. Connect the circuit diagram as shown in Fig.2.
10. Feed the AM wave to the demodulator circuit and observe the output
11. Note down frequency and amplitude of the demodulated output waveform.
12. Draw the demodulated wave form .,m=1

**Observations**

Table 1:  $f_m= 1\text{KHz}$ ,  $f_c=11\text{KHz}$ ,  $A_c=15\text{ V p-p}$ .

S.No.	$V_m(\text{Volts})$	$E_{max}(\text{volts})$	$E_{min}(\text{Volts})$	m	%m (m x100)

Table 2:  $A_m= 4\text{ Vp-p}$   $f_c=11\text{KHz}$ ,  $A_c=15\text{ V p-p}$ .

S.No.	$f_m(\text{KHz})$	$E_{max}(\text{volts})$	$E_{min}(\text{Volts})$	m	%m (m x100)

<b>EXPT. NO:</b> <b>2.</b>	<b>FM Modulation using IC 8038 &amp; Demodulation using slope detector</b>
-------------------------------	--

**AIM:** To generate FM Wave using IC 8038.

**Components:**

Sl.No.	Particulars	Specification	Quantity
1.	Function Generator IC	IC 8038	1
2.	Resistors	as per design	as per design
3.	Capacitors	as per design	as per design

**Theory:**

In telecommunications and signal processing, **frequency modulation (FM)** is the encoding of information in a carrier wave by varying the instantaneous frequency of the wave. This contrasts with amplitude modulation, in which the amplitude of the carrier wave varies, while the frequency remains constant. In analog frequency modulation, such as FM radio broadcasting of an audio signal representing voice or music, the instantaneous frequency deviation, the difference between the frequency of the carrier and its center frequency, is proportional to the modulating signal.

Frequency modulation is widely used for FM radio broadcasting. It is also used in telemetry, radar, seismic prospecting, and monitoring newborns for seizures via EEG, two-way radio systems, music synthesis, magnetic tape-recording systems and some video-transmission systems. In radio transmission, an advantage of frequency modulation is that it has a larger signal-to-noise ratio and therefore rejects radio frequency interference better than an equal power amplitude modulation (AM) signal. For this reason, most music is broadcast over FM radio.

**Procedure:**

- 1) Set 10 V at  $V_{cc}$  to IC 8038 and shorting pin numbers 7 and 8 observe output at 9, 3 and 2 on CRO  
i.e. Square, Triangle and Sine Wave respectively.
- 2) Connect modulating signal of  $V_m=5 V_{p-p}$  and Frequency of 800 Hz to 1.5 KHz between pin 7 and 8 through R-C
- 3) Observe FM output at pin 2.

**Tabular column**

$f_1$	$f_2$	Theoretical o/p $f_2-f_1$	Practical o/p

**Circuit**

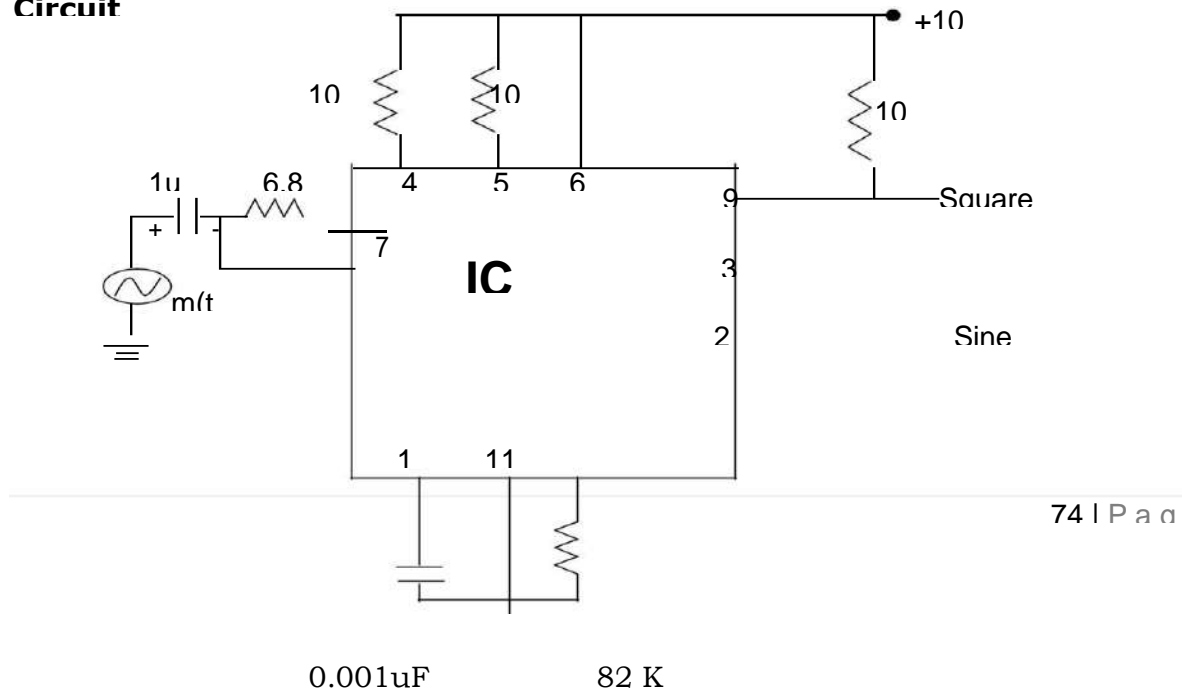

**Waveforms**

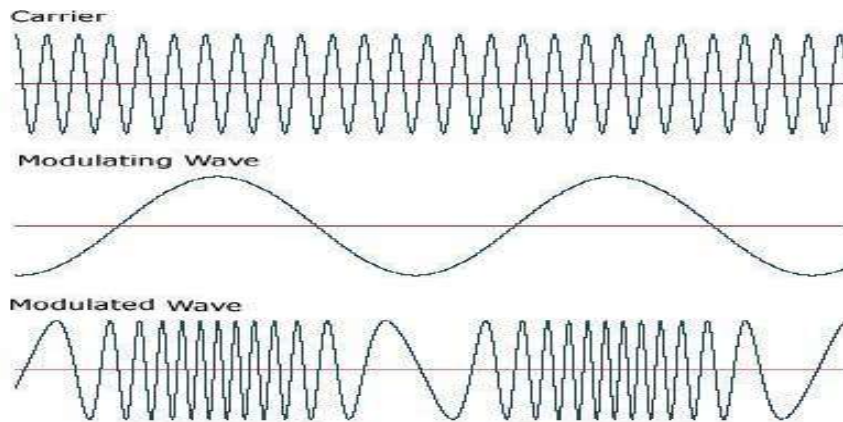

<b>EXPT. NO:</b> <b>3.</b>	<b>PULSE SAMPLING, FLAT TOP SAMPLING AND RECONSTRUCTION</b>
-------------------------------	---

**Aim:** Demonstrate Pulse Sampling, Flat top sampling and reconstruction

**Components :**

<b>Sl.No.</b>	<b>Particulars</b>	<b>Specificat ion</b>	<b>Quantity</b>
1.	SL 100	-	01
2.	Resistors	as per design	as per design
3.	Capacitors	as per design	as per design

**Theory:**

PAM is the simplest of all pulse modulation technique. In PAM the amplitude of the message or modulating signal is mapped to a series of pulses with two possible variant:

- 1) **Flat Top PAM**:- The amplitude of each pulse is directly proportional to instantaneous modulating signal amplitude at the time of pulse occurrence and then keeps the amplitude of the pulse for the rest of the half cycle.
- 2) **Natural PAM**:- The amplitude of each pulse is directly proportional to the instantaneous modulating signal amplitude at the time of pulse occurrence and then follows the amplitude of the modulating signal for the rest of the half cycle. the transmission pulse which can be easily removed if the pulse is in the form of flat top. Here, the top of the samples are flat i.e. they have constant amplitude. Hence, it is called as flat top sampling or practical sampling.. The most common sampler is the sample-and-hold device. The analog signal  $x(t)$  is sampled every seconds. The sampler output holds steady at the last sample value, until a new sample is available. In this way, the sampler output is a staircase approximation to  $x(t)$ .

**Circuit:**

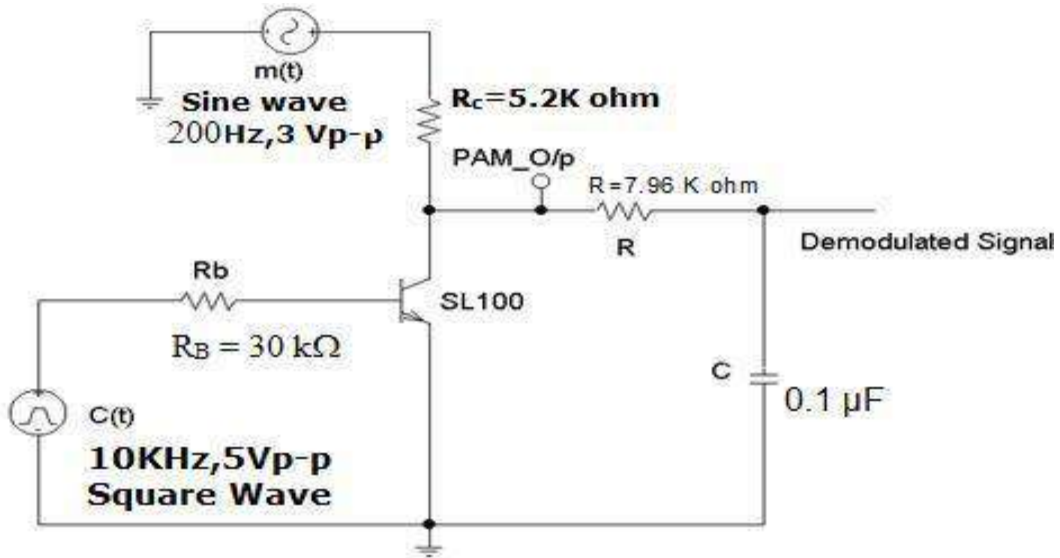

**Demodulator:**

$f = 1/(2\pi RC)$  Assume  $f = 200\text{Hz}$ ,  $C = 0.1 \mu\text{F}$  Hence  $R = 8 \text{ K ohm}$

**Ideal Waveforms:**

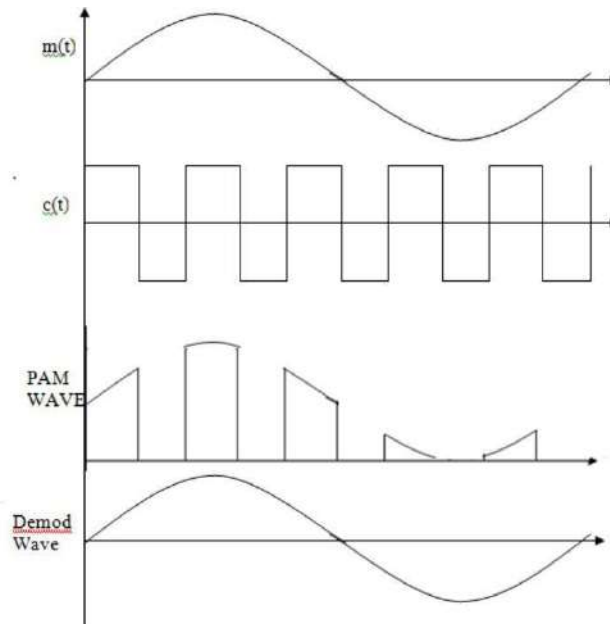

**Procedure:**

- 1) Connections are made as per the Circuit Diagram.
- 2) Adjust  $c(t)$  frequency to 3 KHz and amplitude to 4 Vp-p
- 3) Adjust  $m(t)$  frequency to 300 Hz and Amplitude to 2 Vp-p
- 4) Check the PAM o/p at the emitter by varying the  $c(t)$  and  $m(t)$  amplitude if necessary.
- 5) Rig up the Demodulator Circuit.
- 6) To get Undistorted  $m(t)$  change the  $c(t)$  frequency to higher value i.e. to 10 KHZ.

**Result:**

Pulse Amplitude Modulation and Demodulation o/p is verified

<b>EXPT. NO:</b> 4.	<b>TIME DIVISION MULTIPLEXING (TDM)</b>
------------------------	---

**Aim:** To study Time Division Multiplexing for 2 waves.

**Components:**

Sl No	Apparatus	Range	Quantity
1.	Transistor SL 100 SK 100		2 2
2.	Resistors	10KΩ 1.5KΩ 10KΩ	4 2 4
3.	Capacitor	0.1μF	2

**Theory:**

Time-Division Multiplexing (TDM) is a type of digital or (rarely) analog multiplexing in which two or more signals or bit streams are transferred apparently simultaneously as sub-channels in one communication channel, but are physically taking turns on the channel. The time domain is divided into several recurrent timeslots of fixed length, one for each sub-channel. A sample byte or data block of sub-channel 1 is transmitted during timeslot 1, sub-channel 2 during timeslot 2, etc. TDM is a convenient method for combining various digital signals onto a single transmission media such as wires, fiber optics or even radio.

**CIRCUIT DIAGRAM**

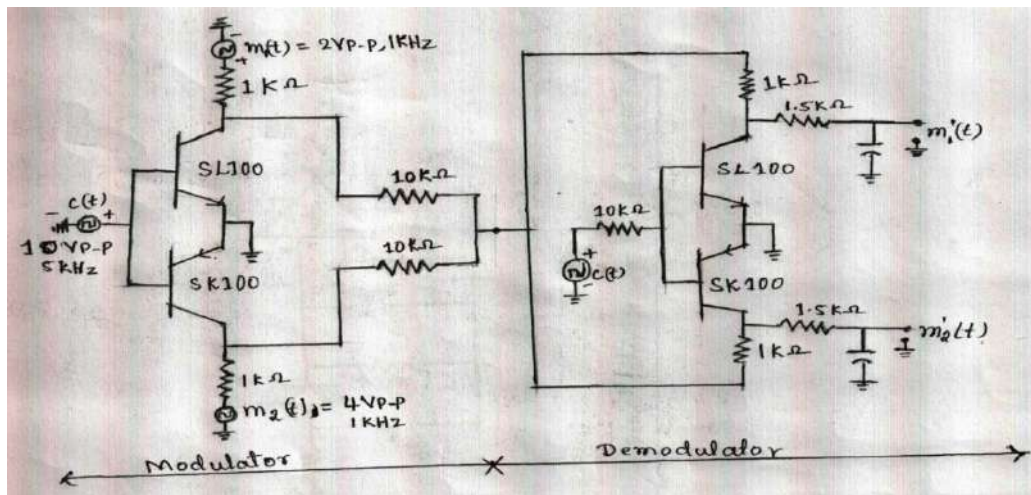

**Design:**

$$f_c = \frac{1}{2\pi RC}, \text{ Let } f_c = 1\text{KHz, and } C_1 = C_2 = 0.1\mu\text{F, } R_1 = R_2 = R =$$

$$1/(2\pi \times 1 \times 10^3 \times 0.1 \times 10^{-6})$$

$$R = 1.591 \text{ K}\Omega \approx 1.5 \text{ K}\Omega$$

**Procedure:**

1. Connections are made as shown in the circuit diagram.
2. Three signals (message and carrier signals) from the signal generator is given to the base and collector of transistor as shown.
3. Observe the TDM output.
4. Complete the demodulation part of the circuit.
5. Observe the demodulation output.

**Waveforms**

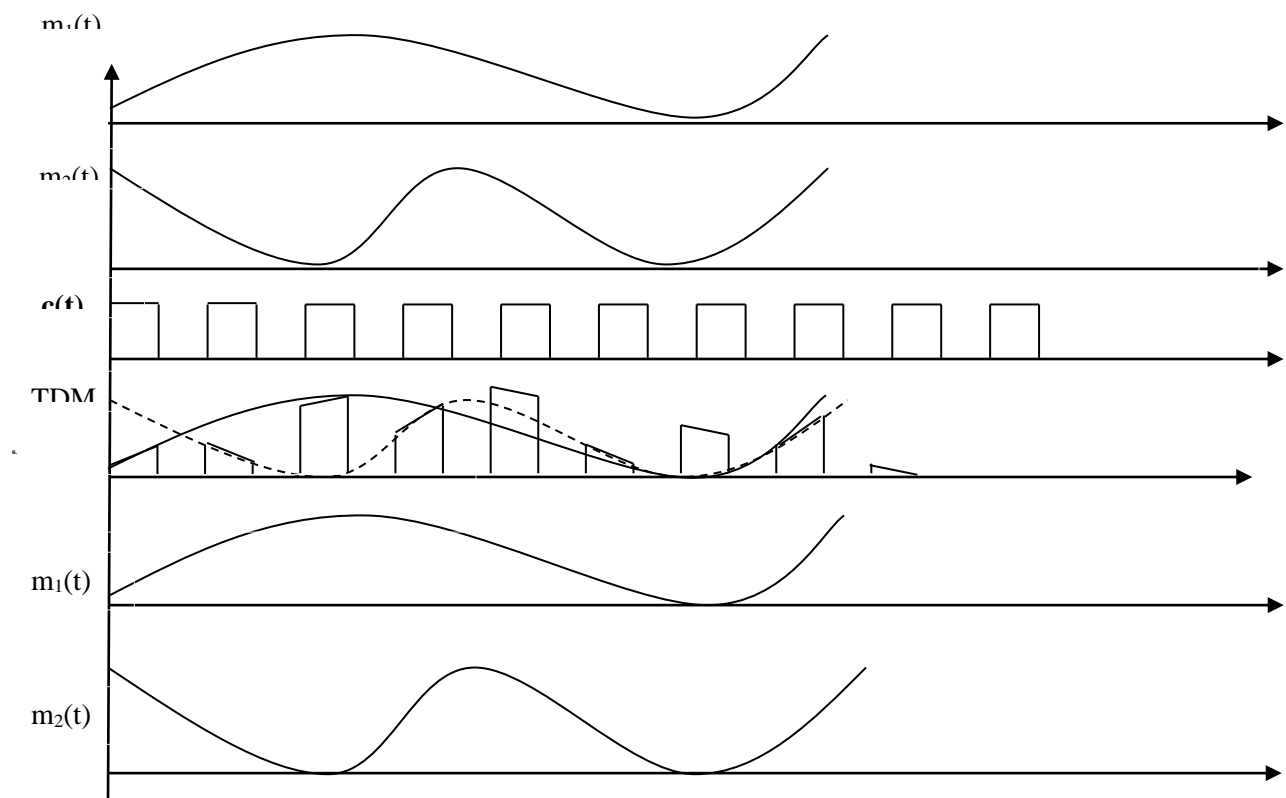

Demodulated Waveforms

**Result:** Time division multiplexed and De-multiplexed waveforms are verified

<b>EXPT. NO:</b> 5.	<b>FSK and PSK generation and detection</b>
------------------------	---

a) **FREQUENCY SHIFT KEYING ( FSK )**b) **Aim:** To generate FSK signal and to demodulate the FSK signal.**Components:**

<b>Sl.No</b>	<b>Apparatus</b>	<b>Range</b>	<b>Quantity</b>
1.	IC $\mu$ A741		3
2.	Transistor	SL100, SK100	1
3.	Diode	OA 79	1
4.	Resistors	1.5K $\Omega$ ,4.7K $\Omega$ ,10K $\Omega$	1,2,4
5.	Potentiometer	20K $\Omega$	1
6.	Capacitor	0.1 $\mu$ F	2

**Theory: Frequency-shift keying (FSK)** is a frequency modulation scheme in which digital information is transmitted through discrete frequency changes of a carrier wave. The simplest FSK is *binary FSK* (BFSK). BFSK literally implies using a couple of discrete frequencies to transmit binary (0s and 1s) information. With this scheme, the "1" is called the mark frequency and the "0" is called the space frequency. The time domain of an FSK modulated carrier is illustrated in the figures to the right. *Minimum frequency-shift keying* or *minimum-shift keying* (MSK) is a particularly spectrally efficient form of coherent FSK. In MSK the difference between the higher and lower frequency is identical to half the bit rate. Consequently, the waveforms used to represent a 0 and a 1 bit differ by exactly half a carrier period. This is the smallest FSK modulation index that can be chosen such that the waveforms for 0 and 1 are orthogonal. A variant of MSK called GMSK is used in the GSM mobile phone standard.

**Circuit Diagram:**

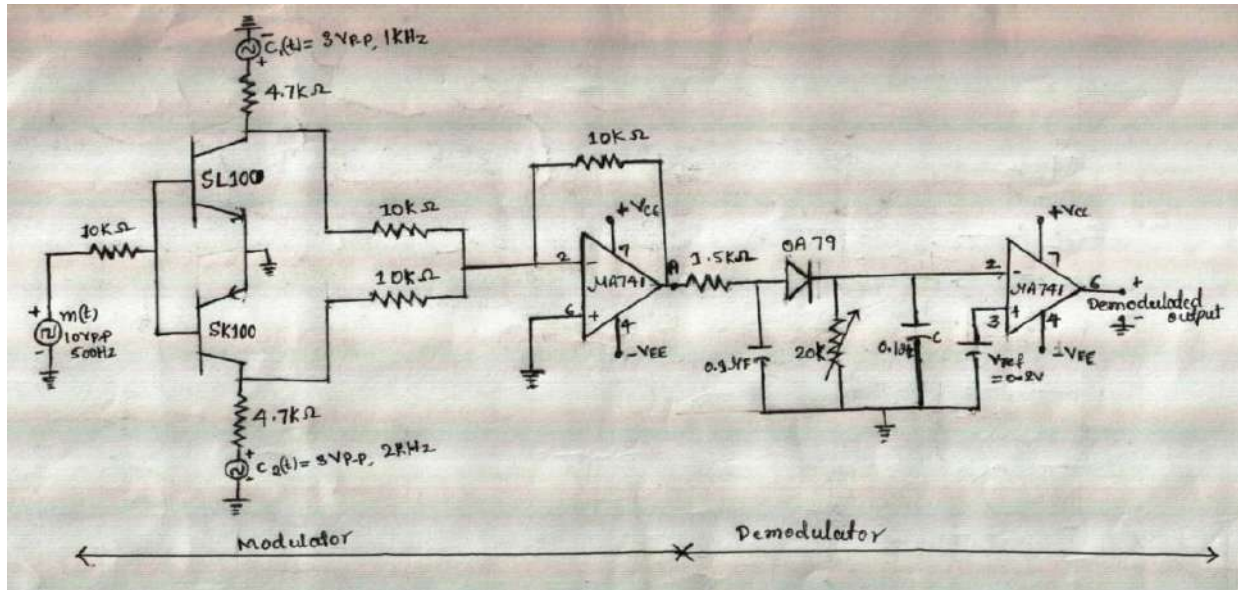

**Design:**

$$f_c = \frac{1}{2\pi RC}$$

**$f_c = 1 \text{ KHz}$ , Assume  $C = 0.1 \mu\text{F}$**

$$T_c < RC < T_m, \quad \frac{1}{f_c} < RC < \frac{1}{f_m}$$

$$\frac{1}{1K} < RC < \frac{1}{500}$$

$$10K\Omega < R < 20K\Omega$$

**Procedure:**

1. Connections are made as shown in circuit diagram.
2. Two sinusoidal carrier signals of 3Vp-p amplitude and one signal is having frequency 1KHz is applied across the collector(SL 100) terminal and the other wave having frequency 2KHz is applied across collector (SK 100) terminal.
3. A message signal having an amplitude 10Vp-p and frequency 500Hz is applied across the base terminal of both the transistors.
4. Observe the FSK output.
5. Demodulate the FSK signal using the envelope detector and comparator.

**Result:**

The Modulated and Demodulated Waves are observed.

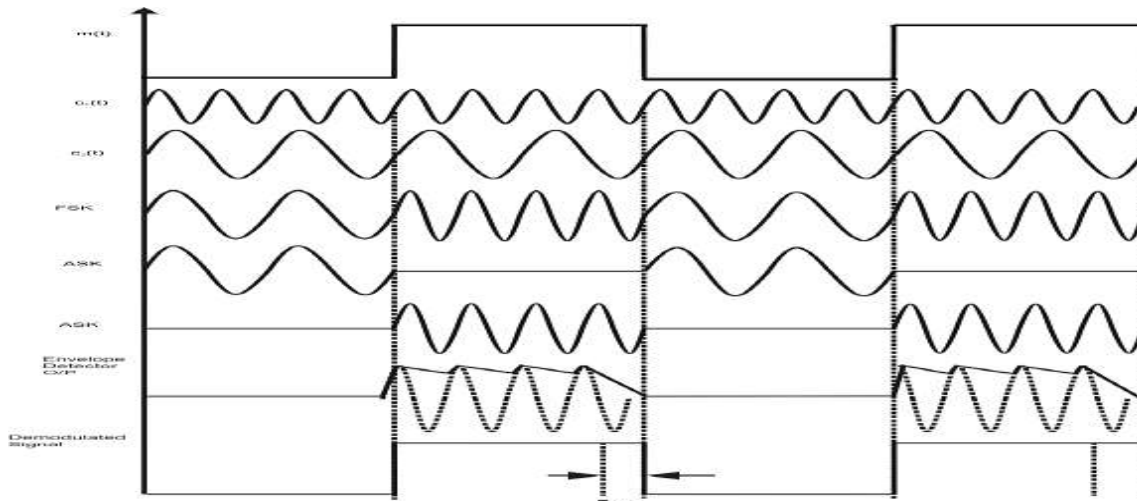
**Waveforms:****c) Binary Phase Shift Keying (BPSK)**

**Aim:** To generate PSK signal and to demodulate the PSK signal.

**Components:**

Sl.No	Apparatus	Range	Quantity
1.	IC s		2
2.	Transistor	SL 100 SK 100	1 1
3.	Diode	OA 79	1
4.	Resistors	100K $\Omega$ 22K $\Omega$ 10K $\Omega$ 2.2K $\Omega$	2 2 10 2
5.	Potentiometer	10K $\Omega$	1
6.	Capacitor	0.01 $\mu$ F 0.1 $\mu$ F	1 2

**Theory: Phase-shift keying (PSK)** is a digital modulation scheme that conveys data by changing, or modulating, the phase of a reference signal (the carrier wave). PSK uses a finite number of phases, each assigned a unique pattern of binary bits. Usually, each phase encodes an equal number of bits. Each pattern of bits forms the symbol that is represented by the particular phase. The demodulator, which is designed specifically for the symbol-set used by the modulator, determines the phase

of the received signal and maps it back to the symbol it represents, thus recovering the original data. "Binary phase-shift keying" (BPSK) uses two phases.

**Circuit Diagram:**

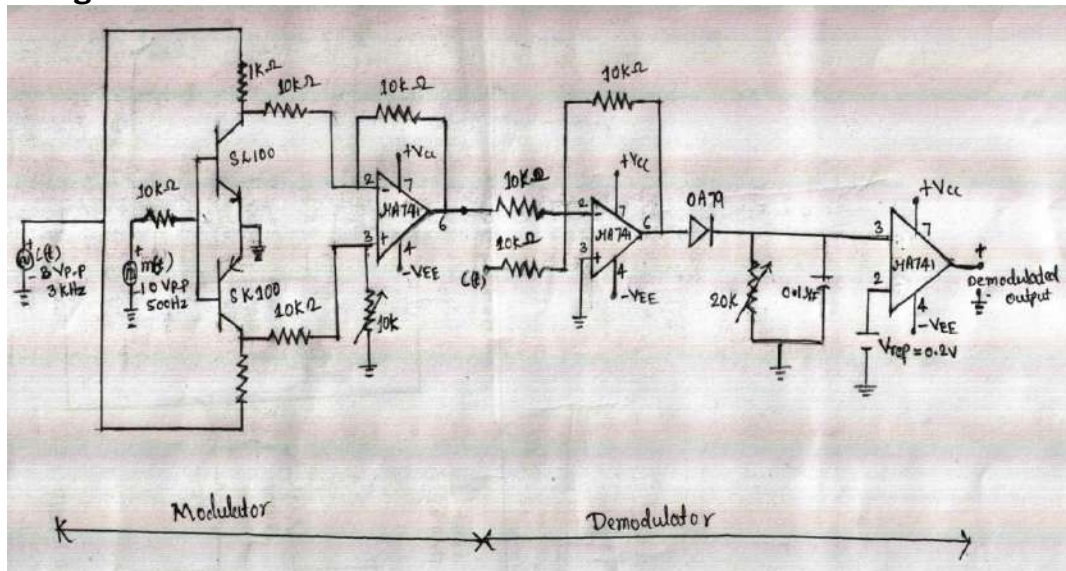

**Design :**

$$T_c < RC < T_m$$

$$RC < \frac{1}{f_m}$$

$$RC < \frac{1}{500}$$

Assume  $c = 0.1\mu F$

$$R < \frac{1}{500 \times 0.1 \times 10^{-6}}$$

$$R < 20K\Omega$$

$$RC > T_c$$

$$RC > \frac{1}{f_c}$$

$$R > \frac{1}{3 \times 10^3 \times 0.1 \times 10^{-6}}$$

$$R > 3.3K\Omega$$

Assume  $3.3K\Omega < R < 20K\Omega$

**Procedure:**

1. Connections are made as shown in the circuit diagram.
2. Apply square wave modulating signal of 500Hz (1000bits/sec) of 10Vp-p.
3. Apply a sine wave carrier signal of 3 KHz of 3Vp-p.

4. Observe BPSK waveform at point A.
5. Demodulate the BPSK signal using Adder, Envelope Detector and Comparator.

**Result:**

The Modulated and Demodulated Waves are observed.

**Waveforms**

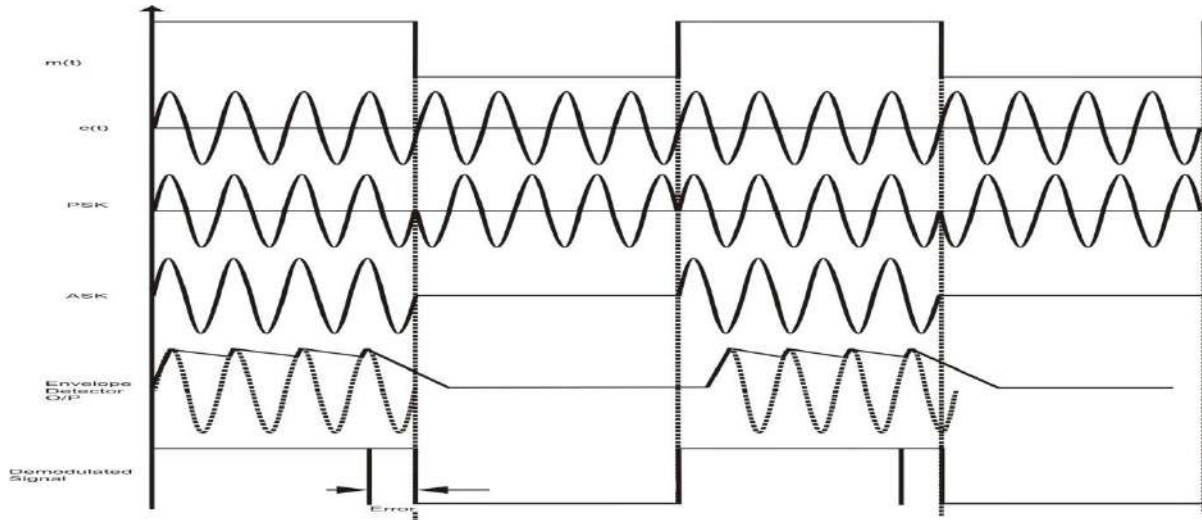

<b>EXPT. NO:</b> <b>6.</b>	<b>Measurement Of Frequency, <math>\lambda_g</math>, Power , VSWR and Attenuation in micro wave test bench</b>
-------------------------------	--

**Aim:** To measure the frequency, guide wavelength, power and VSWR of a microwave guide.

**Components:**

<b>Sl No</b>	<b>Apparatus</b>
1.	Klystron power supply
2.	Klystron Oscillator
3.	Isolator
4.	Frequency meter
5.	Slotted Line Carriage
6.	Movable Short
7.	Crystal detector
8.	CRO

**Theory:** The electromagnetic field at any point of transmission line may be considered as the sum of two traveling waves the incident waves will propagate from the source to the load and the reflected wave which propagates towards the generator. The reflected wave is set up by deflection of incident wave from a discontinuity in the line or from the load impedance. The superposition of the two traveling waves gives rise to a standing wave along the line. The maximum field strength is found where the waves are in phase and minimum where the two waves add in opposite phase. The distance between two successive minimum(or maximum) is half the guide wavelength on the line. The ratio of electrical fields strength of reflected and incident wave is called reflection coefficient. The voltage standing wave ratio (VSWR) is defined as ratio between maximum and minimum field strength along the line.

**Block Diagram:**

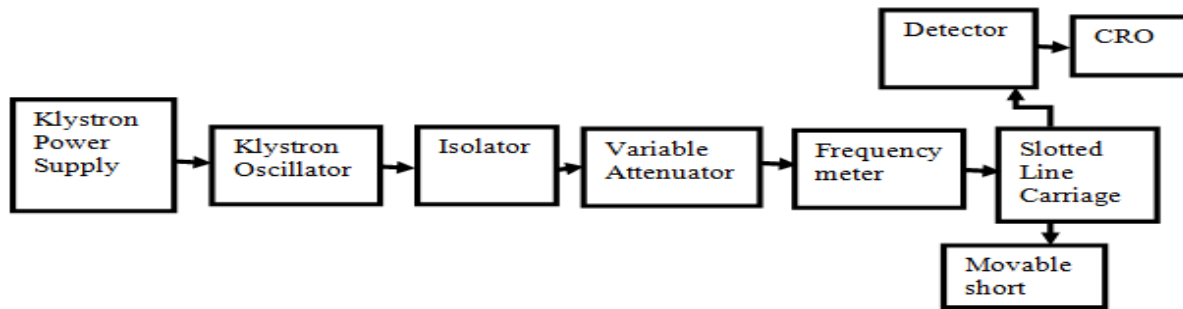

**Calculations:**

$$VSWR = \frac{V_{max}}{V_{min}}$$

$$X_2 - X_1 = MSR + CVD \times LC \text{ cm}$$

$$LC = 0.01$$

$$\lambda_g = \text{Guide wave length} = 2(X_1 - X_2) \text{ cm.}$$

$$\lambda_c = \text{Cut off wavelength} = \frac{2a}{m} \text{ cm}$$

where  $m=1$ ,  $a = 2.3 \text{ cm.}$

$$\lambda_0 = \sqrt{\frac{(\lambda_g \times \lambda_c)^2}{(\lambda_g^2 + \lambda_c^2)}}$$

$$f_0 = \frac{c}{\lambda_0}$$

Where  $c = 3 \times 10^8 \text{ m/s.}$

**Basic Precautions:**

1. During the operation of Klystron, reflector does not carry any current and as such it may severely be damaged by electron bombardment, therefore the negative reflector voltage is always applied before anode voltage. The reflector voltage should never be positive with respect to cavity and should be less than 60V.
2. The reflector voltage should be varied in one direction to avoid hysteresis while doing experiment.
3. The heater voltage should be applied first and external cooling with a fan should be provided simultaneously.
4. While measuring the output the frequency meter should be detuned because there is a power absorption by the meter in its tuned condition.

5. An isolator might be used between Klystron and rest of the setup to avoid loading of the Klystron.

**Procedure:**

1. Set up the microwave bench as shown in block diagram. Switch on cooling fan
2. With Reflector voltage in maximum position and beam voltage in minimum position switch on the Klystron power supply (Both main and HT switch) wait until current reaches 10 to 12mA.
3. Slowly reduce the reflector voltage until we get an undistorted square wave of maximum voltage on the CRO.
4. Measure the frequency of the Klystron oscillator say  $f^1$  using frequency meter. Move the movable short from extreme right until to get maximum voltage on the CRO and note down the corresponding voltage  $V_{max}$ .
5. Again move the movable short to get next minimum voltage on CRO and note down the voltage  $V_{min}$  and displacement ( $X_1$ ) On the carriage and calculate the  $VSWR \frac{V_{max}}{V_{min}}$
6. Again move the movable short to next immediate voltage position and note down displacement ( $X_2$ ).
7. Calculate  $\lambda_g, \lambda_c, \lambda_0$  and  $f_0$  and ensure that  $f_0=f^1$  with  $\pm 0.2 \times 10^9$  difference.
8. Before switching on select AM mode, keep the frequency (AM) to center value and amplitude Knob to maximum.

**Result:**  $\lambda_g=....., f_0=....., VSWR=.....,$

<b>EXPT. NO:</b> 7.	<b>Measurement of directivity and gain of Yagi antenna.</b>
------------------------	---

**Aim:** To conduct an experiment to obtain radiation pattern and to measure the directivity and gain of the Yagi antenna.

**Theory:** If a transmission line, propagating energy is left open with one end there will be radiation from this end. In case of rectangular waveguide this antenna presents a mismatch of about 2 and it radiates in many directions. The match will improve if the open waveguide is horn shape.

The radiation pattern of an antenna is a plot of field strength of the power intensity as a function of the aspect angle at a constant distance from the radiating antenna. The antenna pattern is of course three dimensional but for practical reasons it is normally presented as a two dimensional pattern in one or several planes. An antenna pattern consists of several lobes, the main lobe, side lobes and the back lobes. The major power is concentrated in main lobes and it is required to keep the power in the side lobes and the back lobes as low as possible. The power intensity at the maximum in the main lobe compared to the power intensity achieved from an imaginary Omni directional antenna with the same power fed to the antenna is defined as the gain of an the antenna.

In most of the cases antenna pattern is determined in the far-field region and is represented as a function of the directional co-ordinates.

#### Block Diagram

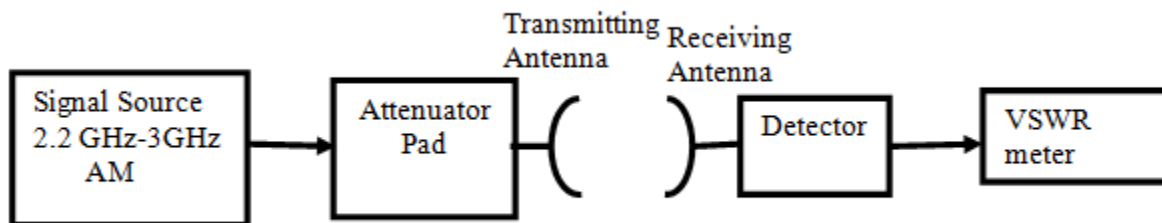

#### Procedure:

1. Set up the system as shown in figure.
2. Mount the two identical Yagi antennas on the two stands.

#### Procedure for switching on the microwave signal source:

1. Keep RF power level knob to minimum position and connect a 3dB attenuator at the RF output (To avoid damage to signal source).
2. First switch on the power supply and then the RF power supply.

**Procedure for switching on the VSWR meter:**

1. Connect a coaxial detector as shown in the figure and keep the range switch to 40dB range and keep the gain knob to maximum position. Range selection is according to our convenience.
2. Switch on the VSWR meter and ensure that distance between transmitting and receiving antenna should satisfy the relation.  $R > \frac{2D^2}{\lambda_0} \approx 50 \text{ cm}$

Where R: Distance between transmitting antenna and receiving antenna.

**Procedure for measurement of RF power input to transmitter antenna:**

1. Connect all 3 attenuator pads (3dB, 6dB, 10dB) at the source output and then connect detector and VSWR meter.
2. Switch on the RF power with source in AM 1 KHz modulation and frequency of 2.4GHz. Set the VSWR range switch to 40 dB and variable gain knob to maximum position.
3. Increase the RF power so that the VSWR meter shows maximum reading in 40 dB range and do not vary this RF power output reading throughout the experiment
4. Switch OFF the RF power output and disconnect and VSWR meter from the source.
5. Connect the equipment as shown in the figure with a distance align the two antennas for the vertical polarization with minimum distance  $R \geq \frac{2D^2}{\lambda_0}$ .
6. Switch ON the RF source if VSWR meter reading does not show any reading. Do not change the RF power level setting at the source.

**Measurement of Gain:**

**Tabular Column:**

R (cm)	$P_{ref}$ (dB)	$P_{ref}$ (dB) (Corrected)	Attenuat or pad removed A(dB)	$P_t$ (dB)	$P_{recv}$ (dB)	$P_t - P_{recv}$ (dB)	$\frac{P_t}{P_r}$	antilog $\left(\frac{P_t}{P_r}\right)$	$\sqrt{\text{antilog}\left(\frac{P_t}{P_r}\right)}$

**Calculation**

$$f=2.4 \text{ GHz} \quad \lambda_0 = \frac{c}{f} \quad \text{Slope} = \frac{y}{x}$$

$$G=10 \log_{10}\left(\frac{4\pi\lambda_0}{\text{slope}}\right) \text{ dB}$$

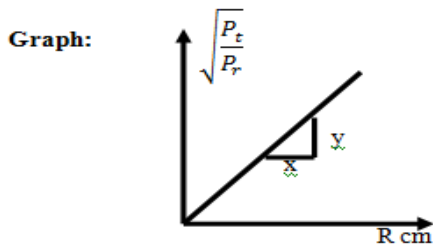

**Procedure for E-plane pattern:**

1. Align the two Yagi antenna along their main beam peaks for horizontal position and set the receiving point at 0°.
2. Set the frequency of the source 2.4 GHz.
3. Adjust the power output of the RF source to indicate high power in dB on the VSWR meter.
4. Rotate the receiving antenna in the clockwise direction in step of 5° till 90° (till meter reading falls to -70dB) and tabulate the readings.
5. Return the receiving antenna to 0° position and ensure the VSWR meter reading is same as before at the beginning.
6. Rotate the receiving antenna in anticlockwise direction in steps of 5° till 90° and tabulate the readings.

**Procedure for H-plane pattern:**

1. Turn both the antennas by 90° and align for maximum response. Set the receiving pointer at 0°.
2. Repeat the steps 3, 4, 5 and 6 of the E-plane and tabulate the readings.
3. Refer the Calibration graph and locate the VSWR meter on the x-axis and find out the corrected value on the y-axis and tabulate the readings.
4. Normalize all the corrected values and tabulate.

5. Plot the E and H pattern on a polar plot showing normalized values in dB Vs the angle.
6. Determine the HPBW for the E and H plane  $\Delta\theta^{\circ}_E$  and  $\Delta\theta^{\circ}_H$  respectively.
7. Calculate the directivity using the formula.

$$D = \frac{32400}{\Delta\theta^{\circ}_E \Delta\theta^{\circ}_H}$$

$$D_{in \text{ dB}} = 10 \log_{10} \frac{32400}{\Delta\theta^{\circ}_E \Delta\theta^{\circ}_H}$$

7. Record R in cm and  $P_{ref}$  in dB value of the attenuator pads removed (A dB) and  $P_{recv}$  (dB).
8. You may remove the attenuator pads to raise the power to transmitter antenna  $P_{recv}$  (dB) , A (dB) for 4 different values of R.

**Tabulation: Measured data for E-plane pattern:**

Angle in Degree	Relative power levels (CW)			Angle in Degree	Relative power levels (ACW)		
	VSWR Reading (dB)	Corrected Value (dB)	Normalized Value (dB)		VSWR Reading (dB)	Corrected Value (dB)	Normalized Value (dB)
0°				0°			
5°				5°			
10°				10°			
15°				15°			
20°				20°			
25°				25°			
30°				30°			
35°				35°			
40°				40°			
45°				45°			
				50°			

**Measured data for H-plane pattern:**

Angle in Degree	Relative power levels (CW)			Angle in Degree	Relative power levels (ACW)		
	VSWR Reading (dB)	Corrected Value (dB)	Normalized Value (dB)		VSWR Reading (dB)	Corrected Value (dB)	Normalized Value (dB)
0°				0°			
5°				5°			
10°				10°			
15°				15°			
20°				20°			
25°				25°			

**COMMUNICATION LAB(18ECL67)**

---

---

30°				30°			
35°				35°			
40°							

D: Maximum size of the antenna.  $\lambda_0$ : Free space wavelength.

**RESULT:** Radiation pattern of Standard dipole, Micro strip patch antenna and Yagi antenna are plotted and also calculated directivity and gain of the antennas.

<b>EXPT NO. 8A</b>	<b>Determination of coupling and isolation characteristics of a stripline (or microstrip) directional coupler</b>
--------------------	---

**Aim:** To conduct an experiment to measure the coupling factor, isolation characteristics of the directional coupler.

**Components required:**

Power supply, VCO, 50  $\Omega$  transmission line, Branch line coupler, parallel line in coupler, 50  $\Omega$  terminations, cables with SMA connector, oscilloscope / VSWR meter.

**Theory:** A directional coupler is a device with which it is possible to measure the incident and reflected wave separately. It consists of two transmission lines the main arm and Auxiliary arm, electromagnetically coupled to each other. The power entering in the main arm gets divided between port 2 and port 3, almost no power comes out in port 4. Power entering at port 2 is divided between port 1 and 4.

**Block Diagram for Directional Coupler:**

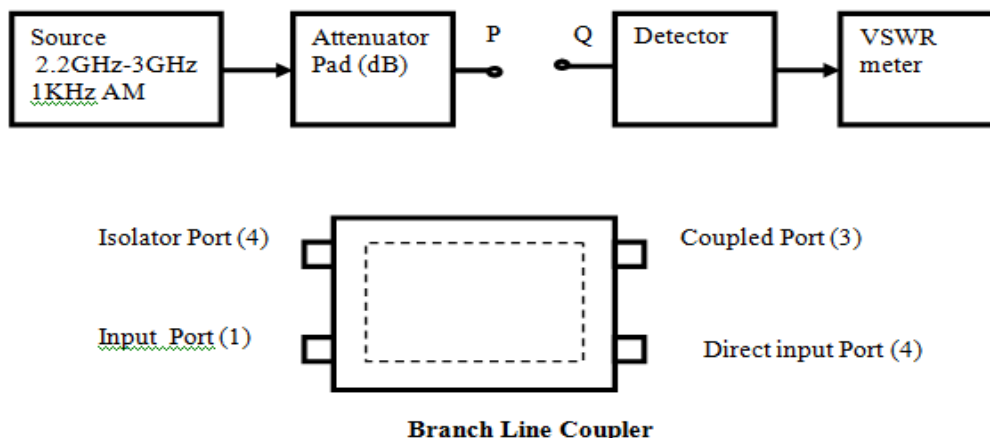

**Procedure for coupling:**

1. Set up the system as shown in block diagram.
2. By connecting 6dB or 10dB attenuator pad, switch on the microwave source using the procedure.
3. Keep the gain knob to maximum and range switch to 60dB, switch ON VSWR meter.
4. Set frequency of microwave to 2 GHz and short ports 3 and 4.

5. Increase the frequency of microwave in 2.2 GHz to 2.8 GHz, note down the VSWR meter reading.
6. Tabulate reading in column 1 and column 2 of the table.
7. Insert the coupler (branch line and parallel coupler) between P<sub>3</sub>, P<sub>1</sub> with input port (P<sub>1</sub>) to P, coupled port (P<sub>3</sub>) to Q and terminate P<sub>2</sub> and P<sub>4</sub> using 500Ω matched load.
8. Record the VSWR meter reading at same frequency on column 2 of table 1

**Procedure for isolation:**

1. Set up the system as shown in block diagram.
2. By connecting 6dB or 10dB attenuator pad, switch on the microwave source using the procedure.
3. Keep the gain knob to maximum and range switch to 60dB, switch ON VSWR meter.
4. Set frequency of microwave to 2 GHz and short ports 3 and 4.
5. Increase the frequency of microwave in 2.2 GHz to 2.8 GHz, note down the VSWR meter reading.
6. Tabulate reading in column 1 and column 2 of the table.
7. Insert the coupler (branch line or parallel coupler) between P and Q and with input port to P and isolated port (port 4) to Q and terminate the ports 2 and 3 using 50Ω natural load.
8. Record the VSWR meter reading at same frequency in column 3 of table 2.

**Tabulation:**

**Coupling Characteristics**

Frequency (GHz)	VSWR Reading		Corrected Reading		Coupling Loss (dB) =P <sub>11</sub> -P <sub>33</sub>
	P <sub>11</sub> (dB)	P <sub>33</sub> (dB)	P <sub>11</sub> (dB)	P <sub>33</sub> (dB)	

**Isolation Characteristics**

Frequency	VSWR Reading		Corrected Reading		Isolation Loss (dB) =P <sub>11</sub> -P <sub>4</sub>
	P <sub>11</sub> (dB)	P <sub>4</sub> (dB)	P <sub>11</sub> (dB)	P <sub>4</sub> (dB)	

**Result:** Coupling factor and Isolation of powder are measured.

<b>EXPT NO: 8B</b>	<b>Measurement of resonance characteristics of a micro strip ring resonator and determination of dielectric constant of the substrate</b>
------------------------	---

**Aim:** To conduct an experiment to measure resonance characteristics of a micro strip ring

resonator and to determine the dielectric constant of the substrate.

**Components required:**

Power supply, VCO, 50  $\Omega$  transmission line, Ring resonator, 50  $\Omega$  terminations, cables with SMA connector, oscilloscope / VSWR meter

**Theory:**

A ring resonator is known as a simple printed resonator that is useful for making approximate measurement of dielectric constant. In principle it is a simple structure, but accurate analysis of a ring resonator is difficult because of the input and output coupling to straight micro strip printed lines. At a ring resonator both the structures are identical; the field would be in the form of a wave circulating around in either direction. It follows that whatever voltage wave is excited in the clockwise direction, an identical voltage wave will be excited in the anti-clockwise direction. This gives rise to the standing wave pattern.

**Block Diagram for Ring Resonator:**

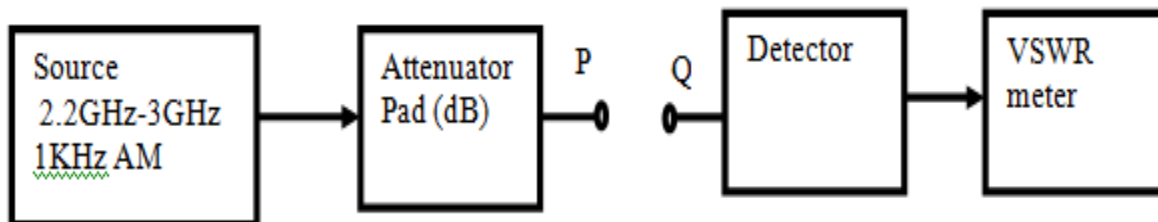

**Procedure:**

1. Assemble the set up as shown in figure with 3 dB attenuator pad.
2. Switch ON the microwave source using procedure.
3. Switch ON the VSWR meter, the range switch is at 40 dB. Set the frequency of microwave source to 2.2 GHz and connect P and Q directly.

4. Increase the power output of the source till the VSWR meter shows reading around 45 dB.
5. Connect the ring resonator between P and Q parallel , you may notice that the power output suddenly drops because wiring resonator offer large attenuation of frequencies other than resonant frequency
6. Vary the frequency of source slowly from 2.2 GHz to 3 GHz and observe the frequency at which VSWR meter shows a sharp peak (if peak is not observed increase the power output of source and vary the frequency again).
7. Notice the frequency at which VSWR meter shows a peak called first order resonant ( $n=1$ ) resonant frequency ( $f_r$ ) of resonator.

**Calculation:**

Given

$R=12\text{mm}$ ,  $w=1.84\text{mm}$ ,  $h=0.76\text{mm}$ ,  $f_r=2.5\text{GHz}$

$$2\pi R = \frac{nV_0}{f_r\sqrt{\epsilon_{ef}}}$$

$V_0=3\times 10^8 \text{ m/s} = 3\times 10^{11} \text{ mm/sec}$ .

Assume  $n=1$  (first order resonant)

$\epsilon_{ef}$  =Effective dielectric constant of substrate.

**Result:** Resonant frequency of ring resonator is  $f_r=$ .....

Relative dielectric constant of substrate is  $\epsilon_r=$ .....

<b>EXPT. NO: 8.C</b>	<b>POWER DIVISION AND ISOLATION OF MICROSTRIP POWER DIVIDER</b>
--------------------------	---

**AIM:** To measure the Power Division and Isolation characteristics of a Micro strip 3dB power divider.

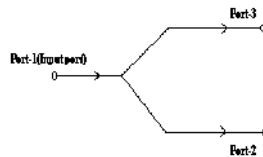

**Fig 12.1: Schematic of an equal split power divider**

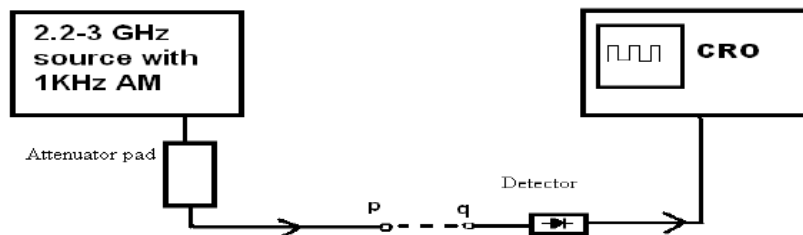

**Fig 12.2: Set up for measuring Power division and Isolation Characteristics of Micro strip Power divider.**

#### **PROCEDURE:**

1. Assemble the setup as shown in the Figure.
2. Procedure for switching 'ON' the microwave signal source
  - (i) Before switching on the signal source, rotate the RF power level knob on the front panel of the signal source anticlockwise to minimum position (lowest power output). Remember to connect a 6dB or 10dB attenuator pad at the RF output port of source).
  - (ii) Switch on the signal source in the following sequence First powers switch to 'ON' position and then RF power switch to 'ON' position. Set modulation switch to AM and modulation frequency to 1 KHz preset position (click at extreme left)
3. Connect the cable end at P to Q directly. Vary the frequency from 2 to 3 GHz in steps of 0.1 GHz and note the corresponding readings (Pd in dB).

**To measure the power division**

1. Insert the power divider between P and Q with input port (port-1) connected to P and the coupled port (port-3) to Q. Terminate port-3 in matched load (50Ω) .
2. Now vary the frequency of the source from 2 to 3 GHz in steps of 0.1 GHz and note the corresponding readings (P2 in dB).
3. Next interchange connections at port-2 and port-3 and repeat the above step and note the corresponding readings (P3 in dB)

**To measure the Isolation.**

1. Remove the power divider from the setup and measure the reference power level again at the same frequencies [Since the values of Isolation are much higher, you can keep the reference level slightly higher].
2. Insert the power divider between P and Q with Port-2 as the input port connected to P and Port-3 to Q, terminate Port-1 in a matched load. Record the readings (P3i in dB) as frequency is varied from 2 to 3 GHz in steps of 0.1 GHz.
3. Determine,
  - Power Division (loss) from Port-1 to Port-2 = Pd (dB)-P2 (dB)
  - Power Division (loss) from Port-1 to Port-3 = Pd (dB)-P3 (dB)
4. Determine the Isolation
  - Isolation (dB) = Pd(dB)-P3i(dB).
5. Plot the Power division (dB) as a function of Frequency. From the plot determine the Centre frequency.
6. Plot Isolation (dB) as a function of Frequency **Measured data for Power division**

Freq(GHz)	Pd(dB)	P2(dB)	P3(dB)	Power division from port-1 to port-2 = Pd-P2	Power division from port-1 to port-3 = Pd-P3

**COMMUNICATION LAB(18ECL67)**

---

2					
2.1					
2.2					
2.3					
:					
:					
:					
3					

**Measured data for Isolation**

Freq(G Hz)	Pd(dB)	P3i(dB)	Isolation between port-2 and port-3, I(dB) = Pd-P3i
2			
2.1			
2.2			
2.3			
:			
:			
:			
3			

**RESULT:**

**PART-B**

1. Simulate NRZ, RZ, half-sinusoid and raised cosine pulses and generate eye diagram for binary polar signaling.
2. Simulate the Pulse code modulation and demodulation system and display the waveforms.
3. Computations of the Probability of bit error for coherent binary ASK FSK and PSK for an AWGN Channel and Compare them with their Performance curves.
4. Digital Modulation schemes: DPSK Transmitter and Receiver.
5. Digital Modulation schemes: DPSK Transmitter and Receiver.

## 1. Simulate NRZ, RZ, half-sinusoid and raised cosine pulses and generate eye diagram for binary polar signaling.

### a. Polar NRZ (Non-Return to Zero)

Code:

```
clc;
clearall;
closeall;
h=input('Enter bit sequence:');
n=1;
l=length(h);
h(l+1)=1;
while (n<=length(h)-1)
    t=n-1:0.001:n;
    if (h(n)==0)
    if(h(n+1)==0)
        y=-(t<n)-(t==n);
    else
        y=-(t<n) + (t==n);
    end
    disp ('zero');

    else
    if(h(n+1)==0)
        y=(t<n)-1*(t==n);

    else
        y=(t<n)+1*(t==n);
    end
    disp ('one');
    end
    d=plot(t, y);
gridon;
title('Line Code Polar NRZ');
set(d,'LineWidth',2.5);
holdon;
axis([0 length(h)-1 -1.5 1.5]);
    n=n+1;
end
end
```

Command Window:

Enter bit sequence:[1 0 1 0 0 1 1 0 1 0]

one  
zero  
one  
zero  
zero  
one  
one  
zero  
one  
zero

Output:

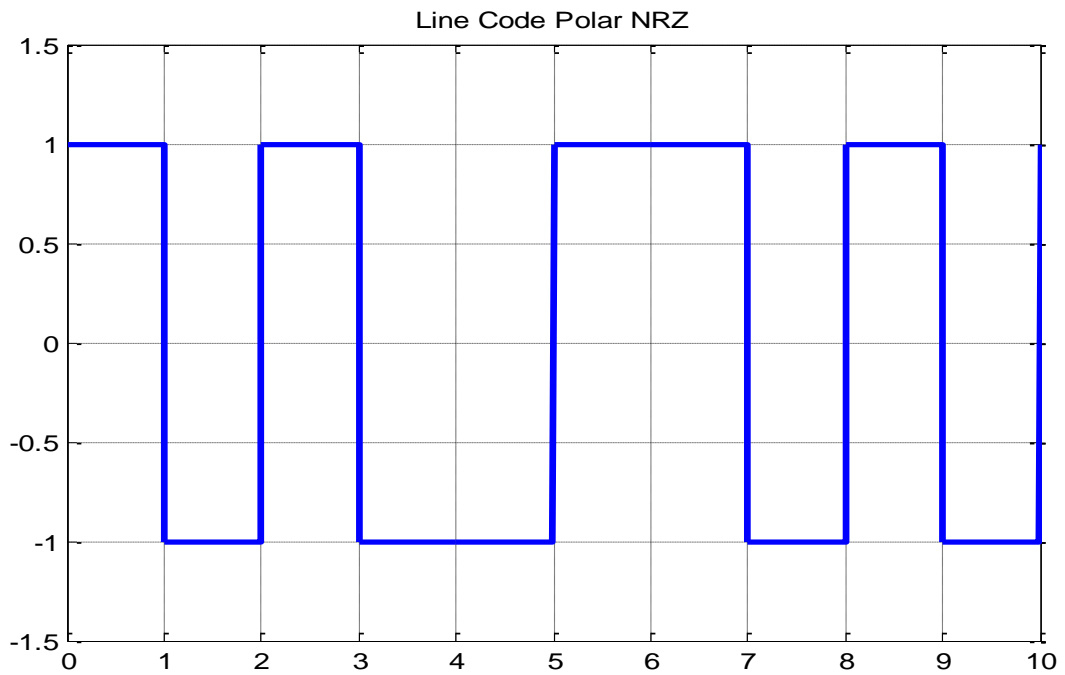

**b. Polar RZ (Return to Zero)**Code:

```
clc;
clearall;
closeall;
h=input ('Enter bit sequence:');
n=1;
l=length (h);
h(l+1)=1;
while (n<=length(h)-1)
    t=n-1:0.001:n;
    if (h(n)==0)
    if(h(n+1)==0)
        y=-(t<n-0.5)-(t==n);
    else
        y=-(t<n-0.5)+(t==n);

    end
    disp('zero');

    else
    if(h(n+1)==0)
        y=(t<n-0.5)-1*(t==n);

    else
        y=(t<n-0.5)+1*(t==n);

    end
    disp('one');
    end
    d=plot (t,y);
    gridon;
    title('Line Code Polar RZ');
    set(d, 'LineWidth',2.5);
    holdon;
    axis([0 length(h)-1 -1.5 1.5]);
        n=n+1;
end
```

Command Window:

Enter bit sequence:[1 0 1 0 0 1 1 0 1 0]

one

zero

one

zero

zero

one

one

zero

one

zero

Output:

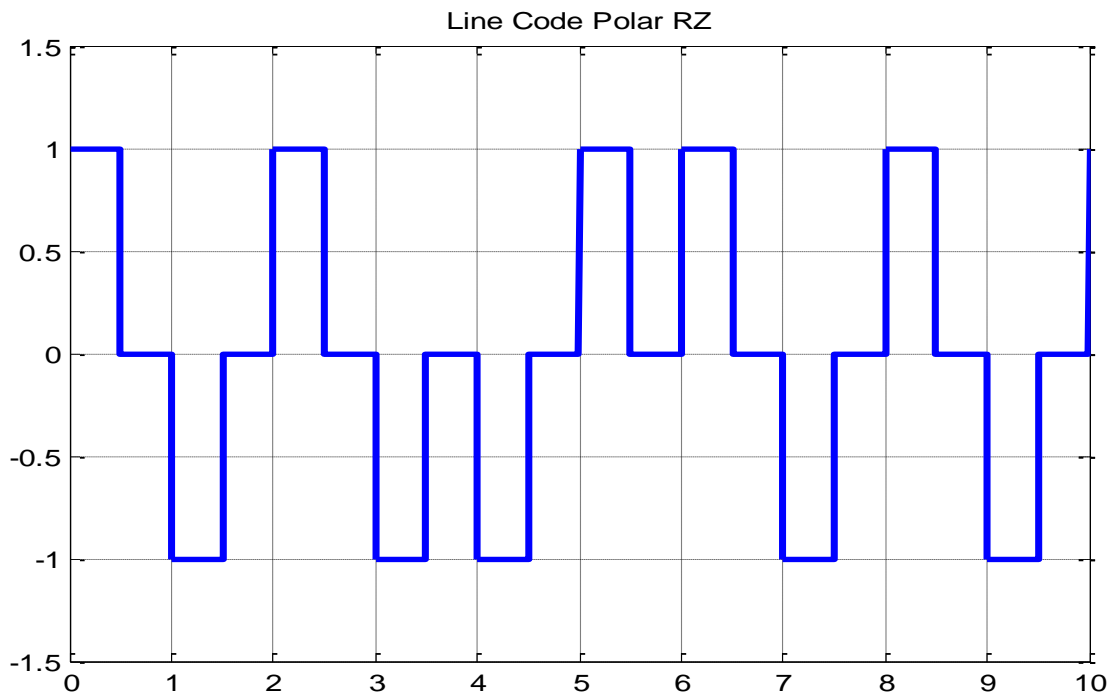

### c. Half-Sinusoid

Code:

```
t = 0:0.2:2;  
f=0.5; %Input Signal Frequency  
x=sin(2*pi*f*t); %Generate Sine Wave  
x(x<0) = 0; %Rectified Positive Half Sine Wave  
figure(1);  
subplot(2,1,1);  
plot(t,x);  
title('Rectified Positive Half');  
ylabel('Amplitude');  
xlabel('Time');  
axis([xlim -1 1]);  
x=sin(2*pi*f*t);  
x(x>0) = 0; %Rectified Negative Half Sine Wave  
subplot(2,1,2);  
plot(t,x);  
title('Rectified Negative Half');  
ylabel('Amplitude');  
xlabel('Time');  
axis([xlim -1 1] );
```

Output:

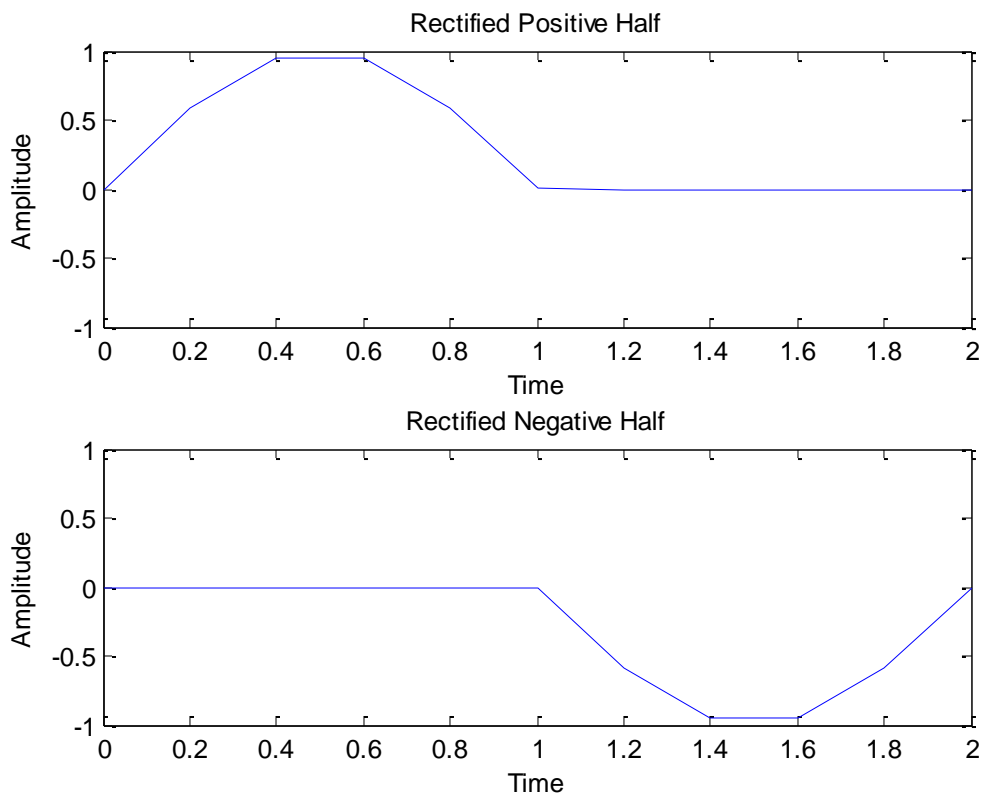

### d. Eye Diagram

Code:

```
%Function prz
function pout = prz(T)
pout= [zeros(1,T/4) ones(1,T/2) zeros(1,T/4)];
end

%Function prcos
function y = prcos(rollfac,length,T)
y=rcosfir(rollfac,length,T,1,'normal');
end

%Function psine
function pout = psine(T)
pout=sin(pi*(0:T-1)/T);
end

%Function pnrz
function pout=pnrz(T)
pout = ones(1,T);
end

%Eye Diagram Code
clc;
clear all;
close all;
data=sign(randn(1,400));
T=64;
for (i=1:length(data))
daTp((i-1)*64+1:i*64)=[data(i) zeros(1,63)];

end
yrz=conv(daTp,prz(T));
yrz=yrz(1:end-T+1);
ynrz=conv(daTp,pnrz(T));
ynrz=ynrz(1:end-T+1);
ysine=conv(daTp,psine(T));
ysine=ysine(1:end-T+1);
Td=4;
yrcos=conv(daTp,prcos(0.5,Td,T));
yrcos=yrcos(2*Td*T:end-2*Td*T+1);
eye1=eyediagram(yrz,2*T,T,T/2);
title('RZ Eye-Diagram');
eye2=eyediagram(ynrz,2*T,T,T/2);
```

```
eye3=eyediagram(ysine,2*T,T,T/2);  
title('Half-Sine Eye-Diagram');  
eye4=eyediagram(yrcos,2*T,T);  
title('Raised-Cosine Eye-Diagram');
```

Output:

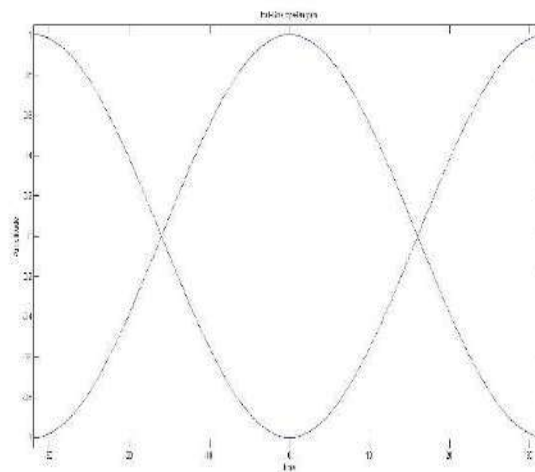
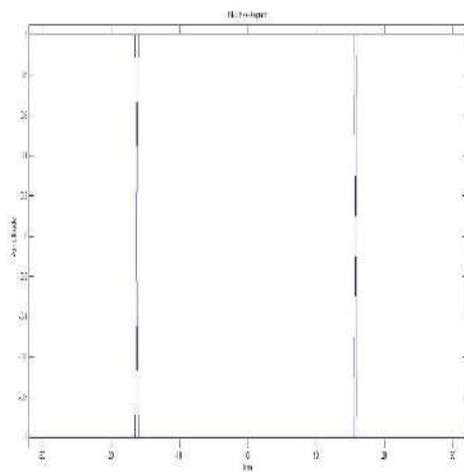
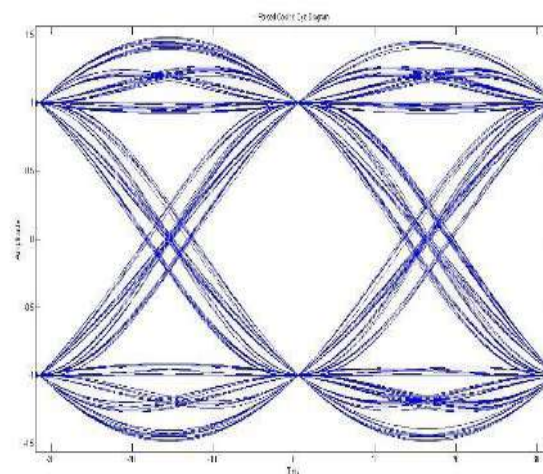
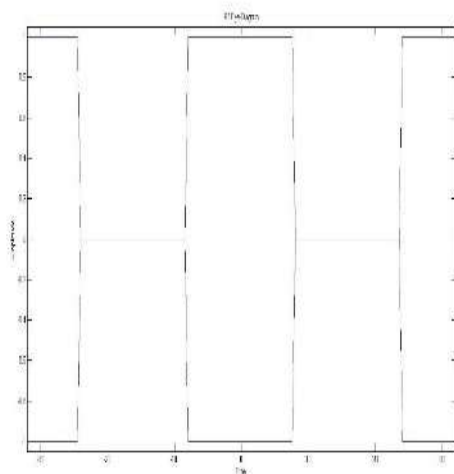

## 2. Simulate the Pulse code modulation and demodulation system and display the waveforms.

Code:

```
clc;
closeall;
clearall;
n=input('Enter n value for n-bit PCM system : ');
n1=input('Enter number of samples in a period : ');
L=2^n;
% % Signal Generation
% x=0:1/100:4*pi;
% y=8*sin(x); % Amplitude Of signal is 8v
% subplot(2,2,1);
% plot(x,y);grid on;
% Sampling Operation
x=0:2*pi/n1:4*pi; % n1 nuber of samples have tobe selected
s=8*sin(x);
subplot(3,1,1);
plot(s);
title('Analog Signal');
ylabel('Amplitude');
xlabel('Time');
subplot(3,1,2);
stem(s);
gridon;
title('Sampled Signal');
ylabel('Amplitude');
xlabel('Time');
% Quantization Process
vmax=8;
vmin=-vmax;
del=(vmax-vmin)/L;
part=vmin:del:vmax; % level are between vmin and vmax with difference of del
code=vmin-(del/2):del:vmax+(del/2); % Contains Quantized values
[ind,q]=quantiz(s,part,code); % Quantization process
% ind contain index number and q contain quantized values
l1=length(ind);
l2=length(q);
for i=1:l1
if(ind(i)~=0) % To make index as binary decimal so started from 0 to N
ind(i)=ind(i)-1;
end
i=i+1;
end
for (i=1:l2)
if(q(i)==vmin-(del/2)) % To make quantize value inbetween the levels
q(i)=vmin+(del/2);
end
end
subplot(3,1,3);
stem(q);
gridon; % Display the Quantize values
```

```
title('Quantized Signal');
ylabel('Amplitude');
xlabel('Time');
% Encoding Process
figure
code=de2bi(ind,'left-msb'); % Convert the decimal to binary
k=1;
for (i=1:l1)
for (j=1:n)
coded(k)=code(i,j); % convert code matrix to a coded row vector
j=j+1;
k=k+1;
end
i=i+1;
end
subplot(2,1,1);
gridon;
stairs(coded); % Display the encoded signal
axis([0 100 -2 3]);
title('Encoded Signal');
ylabel('Amplitude');
xlabel('Time');
% Demodulation Of PCM signal
qunt=reshape(coded,n,length(coded)/n);
index=bi2de(qunt,'left-msb'); % Getback the index in decimal form
q=del*index+vmin+(del/2); % getback Quantized values
subplot(2,1,2);
gridon;
plot(q); % Plot Demodulated signal
title('Demodulated Signal');
ylabel('Amplitude');
xlabel('Time');
```

**Command Window:**

Enter **nvalueofn-bitPCMsystem:4**  
Enter **numberofsamplesinaperiod:8**

Output:

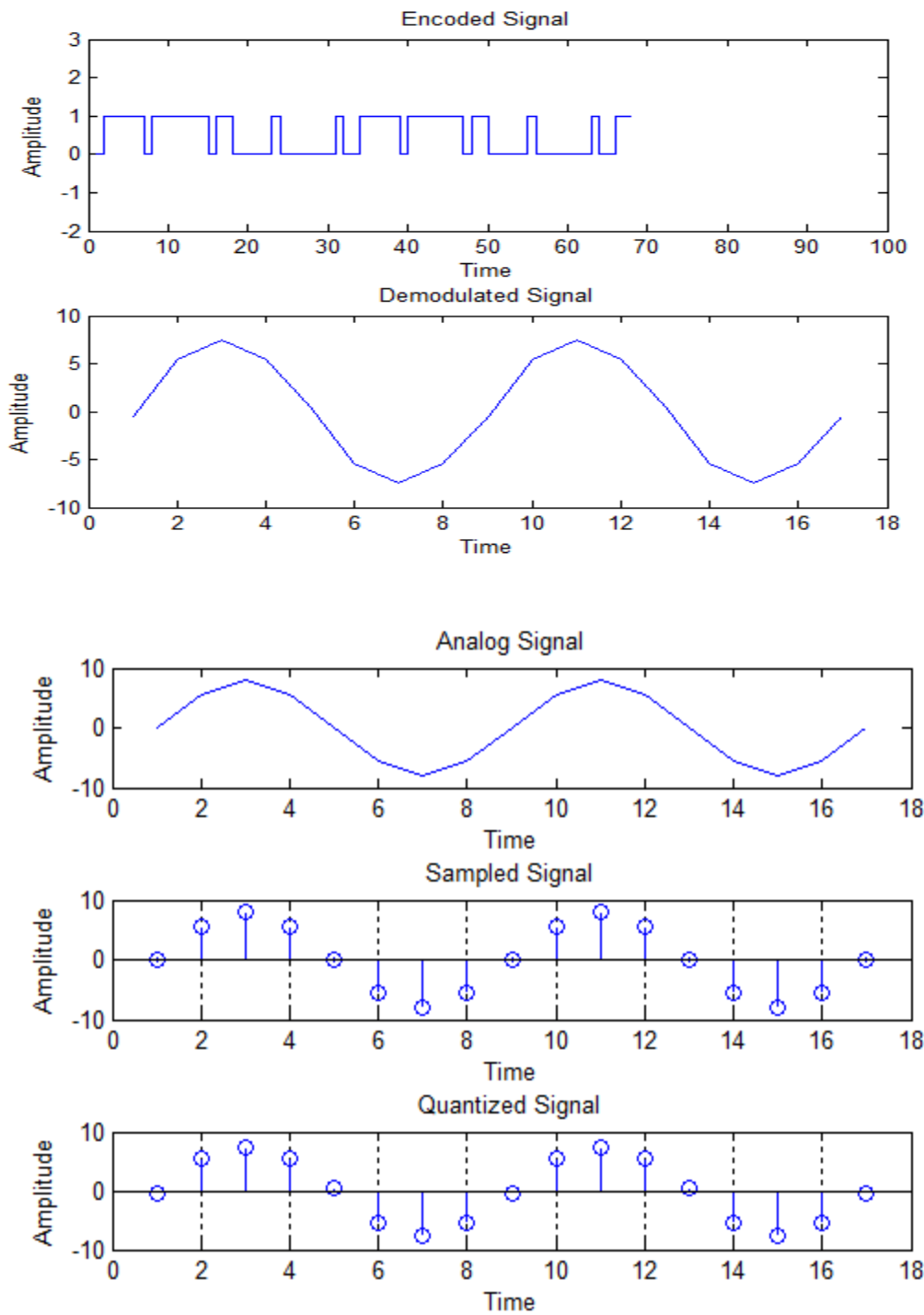

### 3. Computations of the Probability of bit error for coherent binary ASK FSK and PSK for an AWGN Channel and Compare them with their Performance curves.

```

EbN0dB=0:10; %Signal to noise ratio in dB
EbN0=10.^(EbN0dB/10);%Converting SNR from dB to fraction form
pe_bpsk=0.5*erfc(sqrt(EbN0));%BER of BPSK
pe_bfsk=0.5*erfc(sqrt(EbN0/2));%BER of BFSK
pe_bask=0.5*erfc(sqrt(EbN0/4));%BER of BASK
semilogy(EbN0dB,pe_bpsk,'r*-','EbN0dB,pe_bfsk,'k+-',EbN0dB,pe_bask,'m>-');
legend('BPSK-C','BFSK-C','BASK-C')
xlabel('Eb/No (dB) ')
ylabel('BER')
grid on

```

Output:

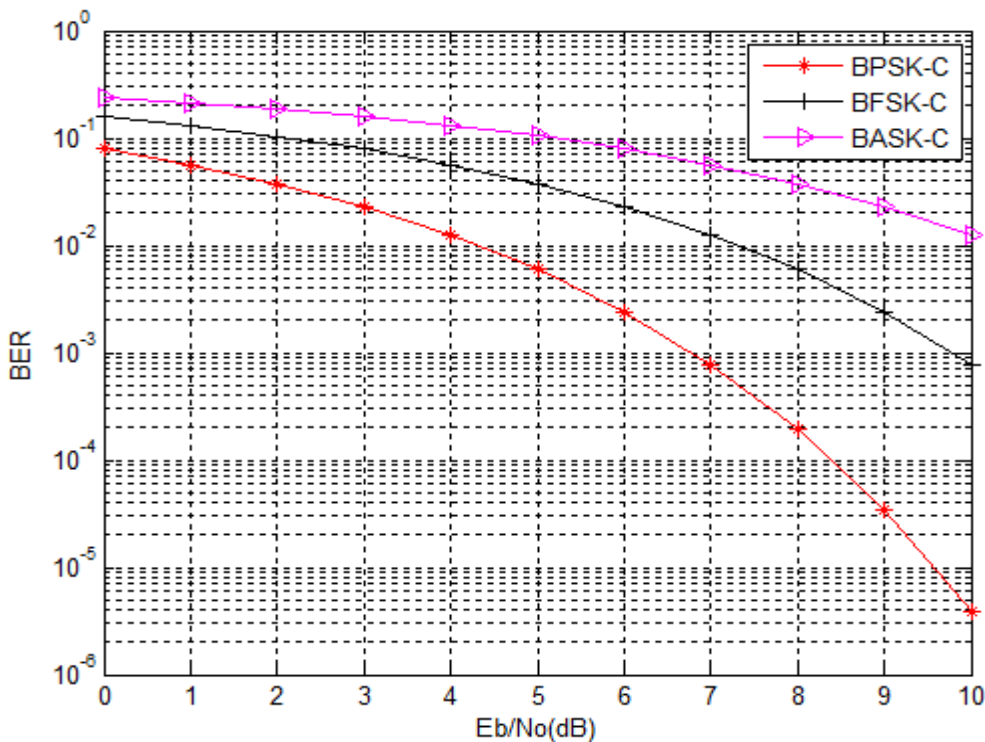

4. Digital Modulation schemes: DPSK Transmitter and Receiver.

```

clc;
clear all;
rng default
M = 6; % Alphabet size
dataIn = randi([0 M-1],1011,1); % Random message
txSig = dpskmod(dataIn,M); % Modulate
rxSig = txSig*exp(2i*pi*rand());
dataOut = dpskdemod(rxSig,M);
errs = symerr(dataIn,dataOut)
errs = symerr(dataIn(2:end),dataIn(2:end))
figure
subplot(2,2,1)
plot(dataIn)
title('DATA')
subplot(2,2,2)
plot(txSig)
title('DPSK SIGNAL')
subplot(2,2,3)
plot(rxSig)
title('Received DPSK')
subplot(2,2,4)
plot(dataOut)
title('DATA RECEIVED')

```

Output:

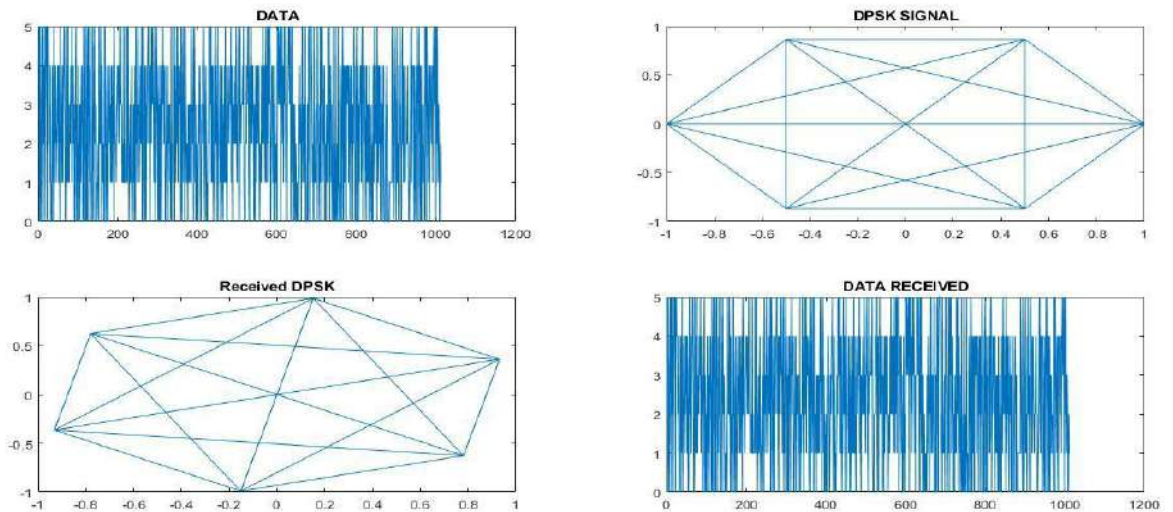

### 5. Digital Modulation schemes: DPSK Transmitter and Receiver.

% QPSK Generation Schemes using MATLAB.

```

clc; clear all;
t=0:0.0001:0.25;
m=square(2*pi*10*t);
c1=sin(2*pi*60*t);
c2=sin(2*pi*60*t+180);
for i=1:2500
if(mod(i,1000)<500
s(i)=c1(i);
else
s(i)=-c2(i);
end
end
subplot(4,1,1);
plot(t,m,'k','linewidth',5);
title('polor representation of message 1 0 1 0 1 0');
xlabel('time'); ylabel('amplitude');
subplot(4,1,2); plot(c1);
title('frequency 1');
xlabel('time'); ylabel('amplitude');
subplot(4,1,3); plot(c2);
title('frequency 2');
xlabel('time'); ylabel('amplitude');
subplot(4,1,4); plot(s);
title('quadrature phase shift keying');
xlabel('time');
ylabel('amplitude');

```

Output:

