

Vijayanagara Technological University Juana Sangama,

Belagavi-590018



**PROJECT REPORT  
ON**

**"EFFECT OF INFILL PERCENTAGE AND STRUCTURE  
IN 3D-PRINTED MATERIALS USING TAGUCHI METHOD"**

Submitted in partial fulfilment of the requirements for the award of the degree of

**Bachelor of Engineering**

In

**Mechanical Engineering**

FOR THE ACADEMIC YEAR 2022-23

Submitted by

<b>LAKSHAY KUMAR SINGH</b>	<b>1SJ19ME027</b>
<b>LIKITH K.N</b>	<b>1SJ19ME028</b>
<b>MOHAMMAD SHOAB</b>	<b>1SJ19ME037</b>
<b>K.G. RAJEEV IYENGAR</b>	<b>1SJ20ME410</b>

Under the guidance of

**Dr. Mallaradhya .H.M**

Associate professor

Department of Mechanical Engineering



**DEPARTMENT OF MECHANICAL ENGINEERING  
SIC INSTITUTE OF TECHNOLOGY**

**POST BOX NO-20 B.B ROAD, CHICKABALLAPUR-562101**

**2022-23**

Visvesvaraya Technological University Jnana Sangama,

Belagavi-590018



PROJECT REPORT  
ON

**“EFFECT OF INFILL PERCENTAGE AND STRUCTURE  
IN 3D-PRINTED MATERIALS USING TAGUCHI METHOD”**

Submitted in partial fulfillment of the requirements for the award of the degree of

**Bachelor of Engineering**

In

**Mechanical Engineering**

FOR THE ACADEMIC YEAR 2022-23

Submitted by

LAKSHAY KUMAR SINGH	1SJ19ME027
LIKITH K.N	1SJ19ME028
MOHAMMAD SHOAIB	1SJ19ME037
K.G. RAJEEV IYENGAR	1SJ20ME410

Under the guidance of

**Dr. Mallaradhya .H.M**

Associate professor

Department of Mechanical Engineering

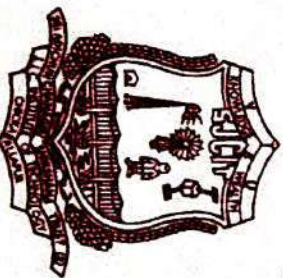

DEPARTMENT OF MECHANICAL ENGINEERING  
SJC INSTITUTE OF TECHNOLOGY

POST BOX NO-20 B.B ROAD, CHICKABALLAPUR-562101  
2022-23

# S J C INSTITUTE OF TECHNOLOGY

Post Box No-29 B Road Chickballapur-562101

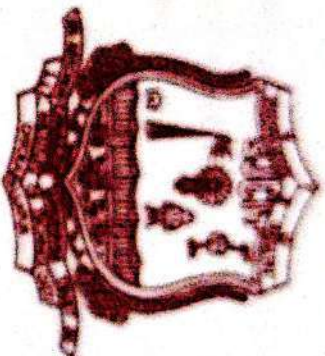

## DEPARTMENT OF MECHANICAL ENGINEERING

### CERTIFICATE

This is to certify that the Project Phase-I entitled -**"EFFECT OF INFILL PERCENTAGE AND STRUCTURE IN 3D-PRINTED MATERIALS USING TAGUCHI METHOD"** is a bonafide work carried out by **LAKSHY KUMAR SINGH (ISJ19ME027), LKITH K N (ISJ19ME028), MOHAMMAD SHOAB (ISJ19ME037) AND K G RAJEEV IVENGAR (ISJ20ME410)** in partial fulfillment for the award of Bachelor of Mechanical Engineering in Visvesvaraya Technological University, Belagavi during the academic year 2022-2023. This project report has been approved as it satisfies the academic requirements in respect of project work prescribed for the bachelor of Engineering Degree.

*Devi*

Principal

*Dr. Mallaradhy H. M*

*Dr. Pragasara N R*

S J C Institute of Technology  
Chickballapur, Bdv. 562 101

Assistant professor

Professor and Head of Dept

Principal

Dept. of Mechanical Engineering

Department of Mechanical Engineering  
S.J.C.I.T.,

SJCIT

CHICKBALLAPUR - 562 101

Name of examiners:

1. *Palarekharsh*
2. *Banavaraja.B.S*

*WVF*  
27/5/23

*Banavaraja*  
28/5/23

## ACKNOWLEDGEMENT

The satisfaction and credit that accompanies the completion of any task would be incomplete without the mention of the people who made it possible. Many are responsible for the knowledge and experience we have gained during this research work.

At the very outset we express our deepest sense of gratitude to our research supervisor **Dr. THYAGARAJ N R** Professor and Head, Department of Mechanical Engineering, S JC Institute of Technology, Chickballapur for his immense interest, constant guidance, and Encouragement throughout my research career.

We sincerely express our hearty gratitude to **Dr. T MUNIKENCHE GOWDA**, Director BGS R&D Canter, SJC Institute of Technology , Chickballapur for his immense interest and support to do this research work with confidence.

We express our deep sense of thanks to, **Dr. MALLARADHYA H M** Assistant Professor Department of Mechanical Engineering for guidance and coordination for his constant support.

We are thankful to project Coordinator **Dr. MALLARADHYA H M** for his guidance, Encouragement and valuable suggestions.

Before concluding, we whole heartedly thank all the staff members and non-teaching of the Department Mechanical Engineering, S J C Institute of technology, for their advice and good Wishes through this project work.

## DECLARATION

We, **LAKSHY KUMAR SINGH, LIKITH K N, MOHAMMAD SHOAIB AND K G RAJEEV IYENGAR** are the students of 8th semester BE. Department of Mechanical Engineering in SIC institute of technology, here we declare that the project work presented in the dissertation entitled "**EFFECT OF INFILL PERCENTAGE AND STRUCTURE IN 3D-PRINTED MATERIALS USING TAGUCHI METHOD**" is an authentic record of the work that has been carried out under the guidance of, **Dr. MALLARADHYA H M** Assistant professor, Department of Mechanical Engineering SIC institute of Technology Chickballapur. The work contained in the report has not been submitted in the part or full to any other university or Institute or Professional body for the award of any degree or any fellowship.

Place: Chickballapur

Date:

**LAKSHAY KUMAR SINGH [1SJ19ME027]**

**LIKITH K N [1SJ19ME028]**

**MOHAMMAD SHOAIB [1SJ19ME037]**

**K.G. RAJEEV IYENGAR [1SJ20ME410]**

## ABSTRACT

Fused Deposition Modelling (FDM) is a process for developing Rapid Prototype (RP) objects by depositing fused layer of material according the cross-sectional geometry designed in the software. Various parameters used in the FDM process significantly affects the quality of parts produced.

Nowadays the parts or objects produced in 3D printing are produced with hundred percent infill rate without any patterns which may give more strength. But in some cases, even with using patterns the objects produced are of more strength and better mechanical properties than required for the application which causes increase in cost and use of more material which is unnecessary.

This work aims to study the effect of process parameters such as infill patterns, infill percentage and printing temperature by keeping other parameters line nozzle diameter, layer height, top and bottom layer thickness, print bed temperature constant during preparation of the test specimens on mechanical properties of FDM printed parts.

In the present project, specimen is made with PLA material having different patterns and different infill percentages which is in turn tested for its mechanical properties like tensile, compression and impact strength. The results are compared with each other using Taguchi method of DOE for various combinations. Thus, this project is conducted to get the average of the strength and mechanical properties. One variable at a time approach has been adopted to carry out the work.

## CONTENTS

CH. NO.	CHAPTER TITLE	PAGE NO.
1.	INTRODUCTION	01-13
2.	LITRATURE SURVEY	14-20
3.	OBJECTIVES	21-22
4.	METHODOLOGY	23-33
	4.1. SELECTION OF PRINTING PARAMETERS	
	4.2. TAGUCHI EXPERIMENTAL DESIGN	
	4.3. MANUFACTURING OF SPECIMEN	
	4.4. PRINTING MATERIAL	
	4.5. PRINTING OF TEST SPECIMEN	
	4.6. TESTING FOR MECHANICAL PROPERTIES	
5.	RESULTS	34-43
	5.1. RESULT OF TENSILE TEST	
	5.2. RESULT OF COMPRESSION TEST	
6.	CONCLUSION	44
7.	SCOPE FOR FUTURE	45-46
	REFERANCES	

## CHAPTER 1:

### INTRODUCTION

3D printing, is a type of nontraditional Additive Manufacturing (AM) technology. It is a process of joining materials to make objects from 3D model data, usually layer upon layer. The product is designed in CAD software, which is then exported to a 3D printer. 3D printing provides a various customization in product design and can even print parts, which cannot be manufactured by any traditional manufacturing processes. Complex and intricate components can be manufactured with substantial reduction in manufacturing time, costs, and material wastage. 3D printing technology has been around in the past two decades, but in the past couple of years it has ascended into a new manufacturing revolution. Earlier, known as Rapid Prototyping (RP), the process was mostly limited to building prototypes and test products. It has evolved over a period into a matured process for being able to fabricate end-user products in various industries. The concept of AM involves building a part from the microscale to the macroscale.

AM is representative of a step in human evolution, as we transition from making products by forging or cutting away to making products by adding material—a method that is closer to natural processes. The most obvious advantage of AM over traditional manufacturing technologies is its capability to handle very complex shapes, and particularly internal shapes. Another advantage of AM is its ability to save material, as no excess material is wasted in AM its use is particularly relevant for precious materials. The other unique advantages of AM, such as its use of gradient materials and its ability to combine different materials into a single structure. These characteristics cannot be obtained by simply replacing the conventional manufacturing process with AM, as this transition is a disruptive change in ideology and methodology from “subtracting” to “adding.” The piece-by-piece addition of a material carries many new variables that will actively or passively affect the final product, including the usage of a single or multiple types of materials, the usage of the same or different conditions in terms of temperature, pressure, or environmental situation and how many chemical elements are present. With AM, it becomes realistic to make a component via a single process involving multiple materials, without the need for any jointing mechanism such as bolts, nuts, and so forth. It is possible, for example, to build a part with different materials that have different

mechanical properties in order to meet different requirements at different locations within the part: these differing properties may include strength, frequency, stiffness, High Cycle Fatigue (HCF) or Low Cycle Fatigue (LCF), corrosion resistance, and creep properties. With AM, it is possible to design a system directly according to end-user requirements, and it is not necessary to compromise due to manufacturing infeasibility. However, jet engine researchers are not yet ready to take advantage of AM's capability to produce multiple-material structures, especially at the microscale. A structure with a gradient material and/or micro-structure on the subsurface can be even more complicated than a composite structure it is neither homogeneous nor isotropic, and there is no distinguished boundary or interface. 3D printing develops durable components by stacking layers of material on each other until the required product is obtained. In the 1990s, 3D printing technologies were deemed ideal only for practical or sample development and RP became a more fitting concept. Today, the precision, consistency and wider range of materials have strengthened to the extent that 3D printing is considered an advanced engineering technique with the name of Additive manufacturing. 3D printed objects can have a complicated structure or shape and are always managed to make from a digital 3D model or a CAD file. Product development through this approach provides many advantages over conventional production techniques. 3D printing is unlikely to replace many of the conventional manufacturing methods, such as turning, milling, drilling and shaping, which have been around for many years and have helped people create products. The first commercial rapid prototyping technology invented by **CHUCK HULL** in 1983.

### 1.1 TYPES OF AM TECHNIQUES:

Based on the strength, geometrical complexity, application, surface finish etc. Selection of various AM techniques will be done. Following are the few AM techniques used broadly.

- Stereolithography (SLA)
- Selective laser sintering (SLS)
- Fused deposition molding (FDM)
- Digital light process (DLP)
- Multi jet fusion (MJF)
- Poly jet
- Direct metal laser sintering (DMLS)
- Electron beam melting (EBM)

## 1.2. THE GENERIC AM PROCESS:

AM involves several steps that move from the virtual CAD description to the physical resultant part. Different products will involve AM in different ways and to different degrees. Small, relatively simple products may only make use of AM for visualization models, while larger, more complex products with greater engineering content may involve AM during numerous stages and iterations throughout the development process. Furthermore, early stages of the product development process may only require rough parts, with AM being used because of the speed at which they can be fabricated.

At later stages of the process, parts may require careful cleaning and post-processing (including sanding, surface preparation, and painting) before they are used, with AM being useful here because of the complexity of form that can be created without having to consider tooling. To summarize, most AM processes involve, the following six steps along with post processing and application. Fig.1.1 shows the generic AM process.

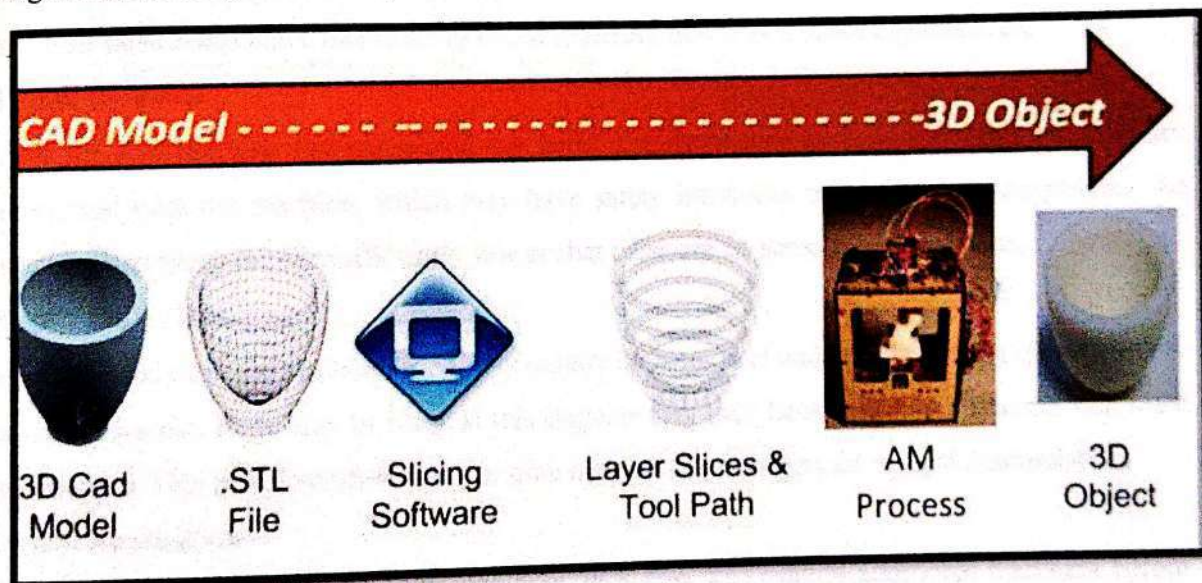

Fig. 1.1 The Generic AM Process

### Step 1: CAD Modelling

All AM parts must start from a software model that fully describes the external geometry. This can involve the use of almost any professional CAD solid modelling software, but the output must be a 3D solid or surface representation. Reverse engineering equipment (e.g., laser and optical scanning) can also be used to create this representation.

**Step 2: Conversion to Stereolithography (STL)**

Nearly every AM machine accepts the STL file format, which has become a de facto standard, and nowadays nearly every CAD system can output such a file format. This file describes the external closed surfaces of the original CAD model and forms the basis for calculation of the slices.

**Step 3: Transfer to AM Machine and STL File Manipulation**

The STL file describing the part must be transferred to the AM machine. Here, there may be some general manipulation of the file so that it is the correct size, position, and orientation for building.

**Step 4: Machine Setup**

The AM machine must be properly set up prior to the build process. Such settings would relate to the build parameters like the material constraints, energy source, layer thickness, timings, etc.

**Step 5: Build**

Building the part is mainly an automated process and the machine can largely carry on without supervision. Only superficial monitoring of the machine needs to take place at this time to ensure no errors have taken place like running out of material, power or software glitches, etc

**Step 6: Removal**

Once the AM machine has completed the build, the parts must be removed. This may require interaction with the machine, which may have safety interlocks to ensure for example that the operating temperatures are sufficiently low or that there are no actively moving parts.

**Step 7: Post-processing**

once removed from the machine, parts may require an amount of additional cleaning up before they are ready for use. Parts may be weak at this stage or they may have supporting features that must be removed. This therefore often requires time and careful, experienced manual manipulation.

**Step 8: Application**

Parts may now be ready to be used. However, they may also require additional treatment before they are acceptable for use. For example, they may require priming and painting to give an acceptable surface texture and finish. Treatments may be laborious and lengthy if the finishing requirements are very demanding. They may also be required to be assembled together with other mechanical or electronic components to form a final model or product.

### 1.1. MATERIALS USED IN AM PROCESS:

The materials used for 3D printing are as diverse as the products that result from the process. As such, 3D printing is flexible enough to allow manufacturers to determine the shape, texture and strength of a product. Best of all, these qualities can be achieved with far fewer steps than what is typically required in traditional means of production. Moreover, these products can be made with various types of 3D printing materials. Following are the different materials used in AM

- Plastic
- Polylactic acid (PLA)
- Acrylonitrile butadiene styrene (ABS)
- Polyvinyl Alcohol Plastic (PVA)
- Polycarbonate (PC)
- Powder
- Polyamide (Nylon)
- Alumide
- Resin
- High-tough resin
- Paintable resin
- Transparent resin
- Metal
- Stainless steel
- Bronze
- Gold
- Nickel
- Aluminum
- Titanium
- Graphite and graphene
- Nickel
- Carbon fiber
- Carbon fiber PLA

Among above mentioned 3D printing material most commonly used material used in FDM is PLA material due to their ease to print and wide range of applications.

#### 1.4. Polylactic acid Material:

PLA material is one of the eco-friendliest options for 3D printers, polylactic acid is sourced from natural products like sugar cane and corn starch and is therefore biodegradable. Available in soft and hard forms, plastics made from polylactic acid are expected to dominate the 3D printing industry in the coming years. Hard PLA is the stronger and therefore more ideal material for a broader range of products.

#### 1.5 Slicing of the selected model:

The act of converting a 3D model into a set of instructions for the 3D printers is called Slicing. Quite literally, it 'slices' the 3D model into thin layers, and further determine how each layer should be printed (the tool path) to get minimum time, best strength, etc. Several supporting tools for Slicing of the models are available and are listed below.

- Cura
- Simplify Slicer
- idea Maker
- OctoPrint
- Astro print
- ChiTuBox
- Netfabb
- Slic3r
- IceSL
- Matter Control
- Repetier
- Craft Ware Pro
- Z-SUITE
- MakerBot Print
- Self-CAD
- 3DPrinterOS
- KISSlicer
- Tinkerine Cloud

### 1.6. Cura:

Cura was developed, hosted, and maintained by 3D printer company Ultimaker and its fervent community of users. Cura slicing software is open source, hence in this project cura slicing software is used.

### 1.7. PARAMETERS INVOLVED IN 3D PRINTING:

Properties of 3D printed materials are depending on various print parameters. In this section, a detailed discussion is done on different parameters.

**Material quality:** Mechanical properties of a material are reflected in a 3D print's features. There are no illusions – poor material properties will affect the quality of a 3D printed object, especially in a field of impact strength and hardness. Moreover, if a low-grade filament is contaminated, the risk of the extruder jamming is rising. The material quality can be measured by its diameter deviation. If a filament's diameter alters rapidly on a small linear distance, we will probably observe some inconsistencies on a 3D printed wall, such as small bulges and cavities. This can happen because a 3D printer extrudes more material (feeding filament of larger diameter) in one moment and deposits less material in another moment, when the filament of a smaller diameter is inserted into print head. In extreme cases, when the material's diameter is too big, it may not fit in the extruder entrance.

**Proper temperature:** This factor is strictly related to the slicer set up that is – most commonly easily accessible by user. The temperature of plastic extrusion must be configured differently for every type of material. To achieve great 3D printing quality using ABS, we need to set high extrusion temperatures of 240- 250°Celsius, and be sure to pump up your building platform temperature to around 100 degrees Celsius. Set fan speed to around 10% to avoid extensive thermal shrinkage and close the build chamber, if your 3D printer has one. To be successful with PLA plastic, set the nozzle temperature to around 200° Celsius and your fan speed to 100% after initial layers are deposited. Heat your build plate to around 50-60° Celsius for the PLA to stick better.

**Retraction:** This feature can be configured in slicing software. Configuration of material retraction is very important when the extruder needs to travel some distances without actual extrusion. In this case, the best way to maintain good surface quality is to set a high speed for material retraction. This will prevent the forming small clods of material on the perimeters. Be prepared to experiment with retraction parameters for your 3D printer in order to get best results.

**Infill density:** The infill density defines the amount of plastic used on the inside of the print. A higher infill density means that there is more plastic on the inside of your print, leading to a stronger object. An infill density around 20% is used for models with a visual purpose, higher densities can be used for end-use parts. This can be calculated by the ratio of weight and volume of the body. Density sometimes depends based the patterns in the 3D printings are done. Fig.1.2 shows the concept of infill density in percentage of the material and amount of the material used.

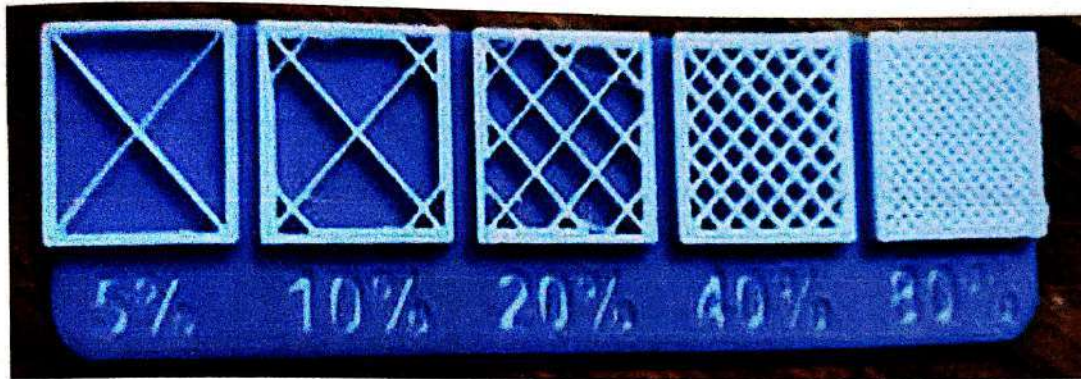

Fig. 1.2 Infill density (percentage)

Infill pattern is the structure and shape of the material inside of a part. Ranging from simple lines to more complex geometric shapes, infill patterns can affect a part's strength, weight, print time, and even flexibility. Across different slicer programs, there are many different infill patterns. For example, Cura (2.2) has a selection of 14 different infill patterns, while Prusa Slicer (2.5) has 17 and Simplify3D has 6. Like infill density, some patterns are better than others for certain functions. Different infill patterns have different attributes, like complexity, material efficiency, and the number of planes of connective strength (2D or 3D). For example, the gyroid pattern connects walls in three dimensions, providing more overall strength. As a result, this pattern takes up more material in comparison to patterns such as lines.

The different types of patterns are listed below:

**Lines:** The lines infill pattern contains lines printed in one direction (either along the X- or Y-axis) every other layer. This infill pattern provides strength in only two dimensions and is good for quick prints. The lines pattern doesn't use too much material and keeps weight pretty light.

**Honeycomb:** As the name implies, this pattern produces a honeycomb structure, making for an appealing visual. This infill pattern is good for semi-fast prints that require moderate strength, and it should not consume too much material.

**Grid:** The grid infill pattern is similar in look to lines, but instead of one-directional lines every other layer, it contains two-dimensional lines every layer, with twice as much space in between lines. This pattern provides two-dimensional strength but is still somewhat strong. The grid pattern consumes an average amount of material and takes a middling time to complete.

**Triangles:** The triangles pattern looks like overlapping triangular lines, with lines going in three directions in the XY-plane. This infill pattern provides strength only in two dimensions but still works for prints that need to be strong.

**Tri-hexagon:** The tri-hexagon infill pattern contains an assortment of lines going in three directions in the XY-plane, creating hexagonal patterns with triangles in between. This infill pattern provides strength in two dimensions and is pretty decent for strong prints.

**Cubic:** This pattern produces stacked cubes, but because they're tilted by 45 degrees around both the X- and Y-axes, they appear more like triangles in any one moment. The pattern provides excellent strength in three dimensions but takes a little more material and time than others.

**Octet:** The octet infill pattern is similar to the cubic pattern, but instead of increasing sloped triangles, the pattern materializes as squares. This infill pattern is a three-dimensional pattern that not only looks really great but is also useful for parts that require strength.

**Gyroid:** The gyroid infill pattern may perhaps look the coolest but it's also arguably the strangest infill pattern. It includes concaving irregular curvatures that eventually cross paths. It's meant to strike an optimal balance between strength, material, and print time.

**Concentric:** The concentric infill pattern is an internal structure composed of concentric lines that match a part's outline (i.e. its perimeters). This pattern is quick to print, good for flexible parts, and consumes significantly less material than most patterns. Fig. 1.3 shows the different patterns available in CURA software to create the objects.

**Bed temperature:** Increasing the temperature above the filament's leads to a reduction of the surface tension between the printing bed and the printing material and to a larger contact area that ultimately causes better adhesion between the bed and the filament. These are controlled by the sensors and heaters inside the 3D printers.

**Speed:** 3D print speed is simply the rate at which the print head moves along the X and Y axes as it puts down a layer of material. A fast 3D print speed will reduce overall print time, but prints printed "fast" can still take a long time — when the part has large dimensions, for instance, or if using a very low layer height.

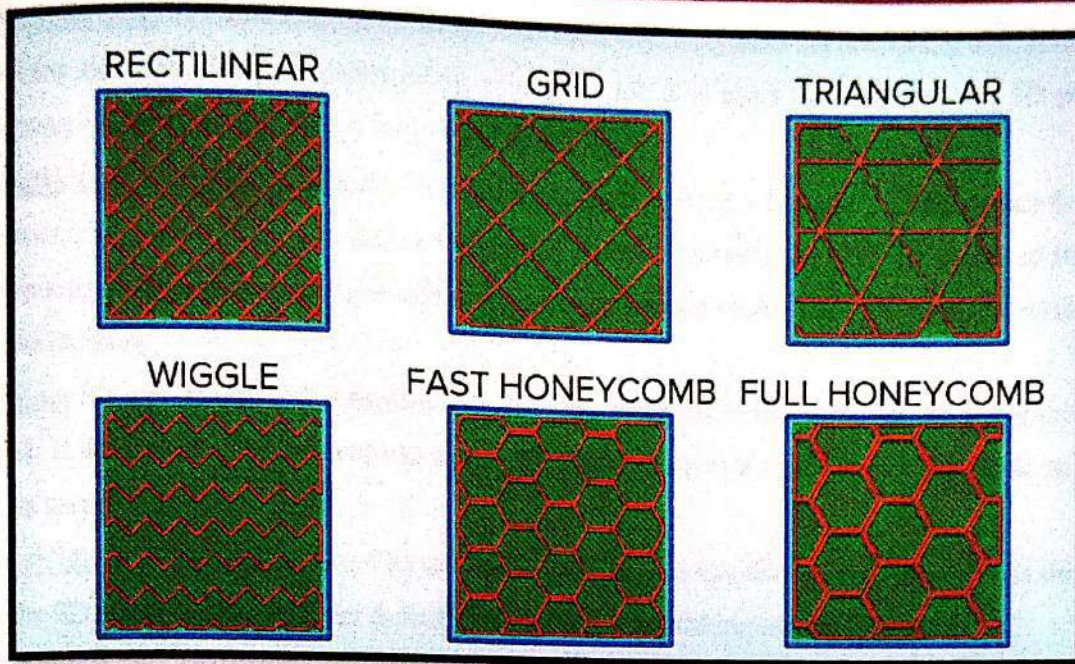

Fig. 1.3 Different infill patterns

**1.8. COMPONENTS OF 3D PRINTING MACHINE:**

In this section, different parts of 3D printer are shown in Fig. 1.4 and discussed in detail.

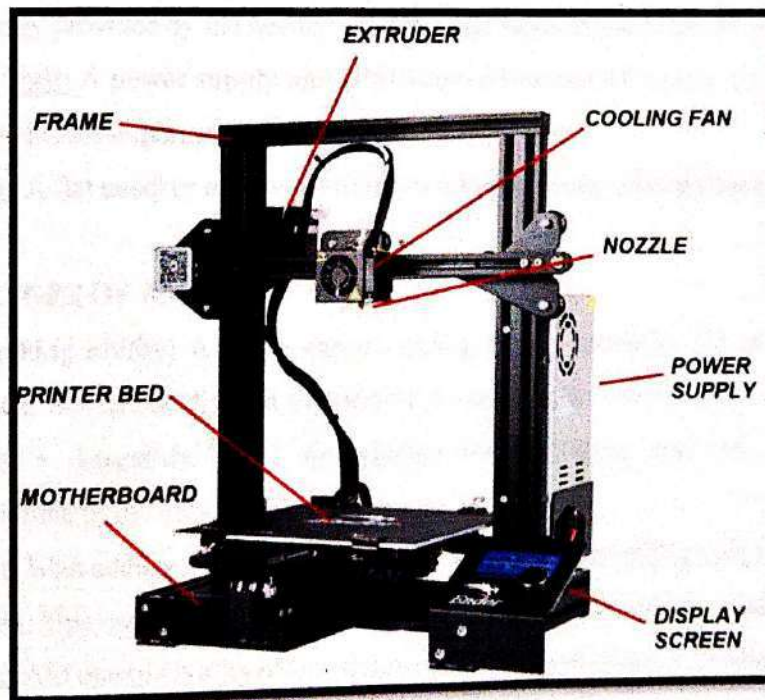

Fig. 1.4 Different parts of 3D printer

**Motherboard:** It is sometimes referred as mainboard which contains the processing unit, memory, and any on board storage capacity of the printer. Its job is to enact the code from the 3D printer software to ultimately produce a 3D printed object.

**Printer bed:** The primary function of a print bed is to provide a flat and smooth surface for the bottom (first) layer to stick to during the print. For this to happen, the print bed needs to form a temporary bond with the first layer of extruded filament so the model does not move mid-print and cause an issue.

**Frame:** It supports all the mechanical and electrical components that carry out the actual printing work. It determines the build volume of the 3D printer. It gives the printer its robust look, as well as its aesthetic appearance.

**Extruder:** Extruder is considered as one of the important components of a 3D printer. It is the part of the 3D printer responsible for drawing in, melting, and pushing out the filament.

**Programmable controller:** Used to program the 3D printer according to the design of specimen to be produced.

**Cooling fan:** The job of the layer fan is to cool the plastic once it has been deposited so that the part solidifies quickly and the molten plastic does not become deformed.

**Nozzle:** The nozzle is the mechanical part of the 3D printer that extrudes the filament. It conducts the thermal energy provided by the heating cartridge and block to the filament, melting it.

**Power Supply Unit:** A power supply unit (PSU) converts mains AC to low-voltage regulated DC power for the internal components of a printer.

**Display screen:** A flat panel or area on a printer on which printing related data is displayed.

## 1.9. ADVANTAGES OF AM:

**Rare shape-making ability:** Additive manufacturing is very attractive for unusual or complex component shapes that can be difficult to manufacture using other processes.

**Manufacturing + Assembly in 1:** An additive manufacturing line can produce multiple components at a time in the same build box.

**No tooling cost:** With additive manufacturing, there is no up-front tooling cost like you would see in traditional PM. This can also be a very attractive benefit to a low-volume production strategy.

**Customization:** AM manufacturing offers design innovation and creative freedom without the cost and time constraints of traditional manufacturing.

**Material waste reduction:** AM starts from scratch, adding material to create a component or by part. By using only the substance necessary to create that part, AM ensures minimal waste.

**Cheap Manufacturing:** 3D printing helps companies save up to 70 percent of their manufacturing cost and lesser workforce needed

**Better Quality:** Avoiding most of the mass manufacturing faults does not only make better products but it also extends their life as they will break less often.

**Sustainability:** Less waste compared to traditional manufacturing methods is not only a cost saving feature of 3D printing but also a possible eco-friendly attribute.

### 1.10. DISADVANTAGES OF AM:

**Surface finish:** There are two major challenges. One is the overall finish capability and the other is the layering effect inherent in AM part construction.

**Dimensional control:** When processed through binder jetting, metal additive manufacturing has dimensional challenges similar to metal injection molding. Namely, the material shrinks by about 20% during sintering.

**It's slow and has size limitations:** Industrial adaptation to additive manufacturing has been slow, and it's still considered a niche process even in 2021. That's because after all these years, AM is still not an efficient way of producing a high volume of parts.

**Cost of entry:** With additive manufacturing, the cost of entry is still prohibitive to many organizations and, in particular, smaller businesses.

**Limited Materials:** Currently, 3D printers only manufacture products out of plastic, resin, certain metals, and ceramics. 3D printing of products in mixed materials and technology, such as circuit boards, are still under development.

**Post processing:** Although large parts require post-processing, as mentioned above, most 3D printed parts need some form of cleaning up to remove support material from the build and to smooth the surface to achieve the required finish.

### 1.11. APPLICATIONS OF AM:

Areas of application of 3D printers

- Industrial design
- Automotive and aviation industries
- Architecture
- Food industry
- Medical industries
- Jewelry
- Footwear
- Engineering and construction

### 1.12. DESIGN OF EXPERIMENTS (DOE):

It is a methodology that can be effective for general problem solving, as well as for improving or optimizing design and manufacturing process.

It is a systematic, efficient software that enables scientists and engineers to study the relationship between multiple input variables and key output variables. MINITAB is a data analysis-based software that is used for data analysis like statistical analysis, regression analysis with the help of TAGUCHI and ANOVA methods. It is also used in analytics market. It is a structured approach for collecting data and making discoveries.

**Taguchi array method:** It is a statistical method developed by GENICHI TAGUCHI to improve the quality of manufactured goods. It is one of the best experimental methodologies used to find the minimum number of experiments to be performed within the permissible limit of factors and levels. It is more popular than other methods as it is easy to understand and also due to its practicality in designing high quality systems that provide much reduced variance for experiments with an optimum setting of process control parameters.

**Anova method:** ANOVA stands for analysis of variance. It was developed in 1918 by RONALD FISHER. It is a statistical formula used to compare variances across the means (or average) of different groups, it is a valuable tool in tests that measure the degree to which levels or groups of an independent variable differ from each other. There are two types in it one-way Anova and two-way Anova.

**CHAPTER-2:****LITERATURE REVIEW**

The earliest 3D printer originated in 1981, when Dr. Hideo Kodama invented one of the first rapid prototyping machines that created parts layer by layer, using a resin that could be polymerized by UV light. The first patent for SLA was filed by Chuck Hull who is considered “the inventor of 3D printing” for creating and commercializing both SLA and the STL format- the most commonly file type used for 3D printing.

In 1988, Carl Deckard, a student at the University of Texas, licensed selective laser sintering (SLS) technology – another type of 3D printing that uses a laser to sinter powdered material into solid structures. Shortly after, in 1989, Scott Crump patented fused deposition modelling (FDM) – also known as fused filament fabrication (FFF) – and founded Stratasys, one of the main players in the 3D printing industry to this day. That same year, Hull’s company, 3D Systems Corporation, released the SLA-1 3D printer Fig. 2.1 shows the evaluation of 3D printer.

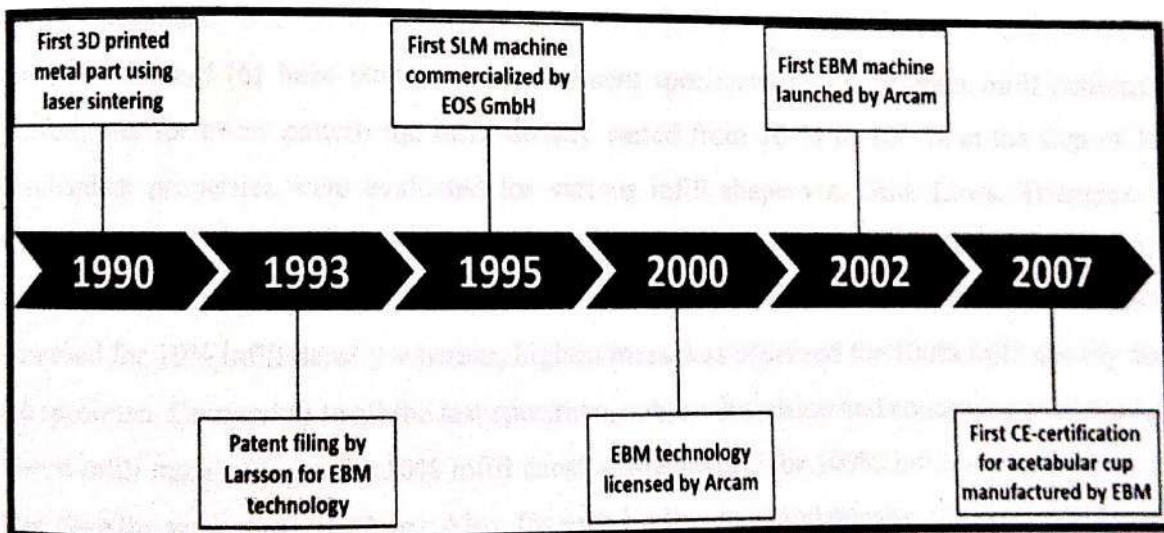

**Fig.2.1. Evolution of 3D printer**

*Todd letcher.et.al* [1] These two people together researched about the material properties of the PLA with an entry level 3D printer. From this we came to know that how the specimen is created according to ASTM standards and its grain structure with various mechanical tests.

**Chris.et.al [2]** They studied the samples of 3D printed materials produced with different infill structures and infill percentages to guide the mechanical design of the 3D printed objects for better mechanical properties and better strength. From this we have come to know, what samples should be produced according to the ASTM standards, and an idea of how the sample might behave under various mechanical testing.

**Surendra.et.al [3]** They both studied and experimented about the PLA material and 3D printing and how the specimen will behave when it is produced under FDM 3D printer and tested for various mechanical properties. From this we came to know how the specimen will behave under 3D printer of different operational process other than that of standard process.

**Alexey.et.al [4]** These two people and with their partners studied and researched about the strength of the PLA components fabricated with FDM using a desktop 3D printer as a function of geometrical parameters of the process. From this study we came to know about the physical properties of the PLA material and behavior under certain testing conditions.

**Jonathan torres.et.al [5]** These people studied the behaviour of the 3D printed specimen produced using FDM process and tabulated its values using ANOVA method. From this study we came to know about the test specimen design and specifications that are used in torsional testing of the 3D printed specimen.

**Adi Pandzic.et.al [6]** have studied for experiment specimens in 13 different infill patterns are printed, and for every pattern the infill density varied from 10 % to 100 % in the step of 10%. Mechanical properties were evaluated for various infill shape viz. Grid, Lines, Triangles, Tri-Hexagon, Cubic, Cubic subdivision, Octet, Quarter Cubic, Concentric, Zig-Zag, Cross, Cross 3D, and Gyroid. Printing time for all the specimen were also recorded and found that lowest mass was observed for 10% infill density whereas, highest mass was observed for 100% infill density for all the specimen. Comparing to all the test specimen, cubic subdivision and concentric infill type gave lowest infill mass of 6 gm for 10% infill density. Meanwhile for 100% infill density, all the infill type gave the same mass of 12 gm. Also, for each infill pattern and density, the time of 3D printing and the amount of material consumed per specimen are presented. Concentric has taken lower time of 45 min at 10% of infill density and Rest all the infill shapes at 100% of infill density as taken 93 min of duration.

By conducting this experiment, they resulted and concluded that by telling all infill patterns have maximum ultimate tensile strength and yield strength for 90% of infill shown in the figure.

Results also showed that with 100% infill, PLA material have 42.15 MPa of ultimate tensile strength and 36.40 MPa of yield strength. If ultimate tensile and yield strength for all infill patterns with 90% infill are compared with 100% infill, difference is about 40%. Also, the highest ultimate tensile strength and yield strength have "Concentric" infill pattern with 90% of infill. They Concluded by saying that if product need maximum tensile properties, it has to be 3D printed with 100% infill. Also, if modeler want to save time and amount of 3D printed material, and decrease infill density from 100% to 90%, product of PLA material will have reduced ultimate tensile strength and yield strength for 40%. Also, results are showing that "Concentric" infill pattern gives the highest ultimate tensile strength and yield strength. Comparing with 100% infill, with "Concentric" infill pattern of 90%, ultimate tensile strength is reduced for only 15% and yield strength for 20%, and printing time is reduced for 30%.

**Mohammadreza Lalegani Dezaki, et. al** [7] study investigates the effects of combined infill patterns in 3D printed products. Five patterns viz. solid, honeycomb, wiggle, grid, and rectilinear were combined in samples to analyses their effects on mechanical properties for tensile strength analysis. PLA samples were printed in different build orientations through two directions: flat and on-edge. The limitation was that the software and machine could not combine the infill patterns. Thus, the patterns were modeled and assembled in CAD software. FEA was used to determine the patterns' features and results showed honeycomb and grid have the highest strength while their weights were lighter compared to solid. This means by using grid and honeycomb patterns, printing strong product is achievable while the weight is minimized. It should be noted, honeycomb had a lower weight with 1.39 gm than grid pattern with 1.68 gm.

The rectilinear pattern had the largest value in stress-strain value while the solid sample showed the highest durability and lowest value of stress. Force-displacement diagrams were analysed to identify the displacements of patterns under tensile loads. The rectilinear pattern has the highest displacement at 1000 N while the lowest one is for solid. The displacement of honeycomb and grid sample were almost the same around 3 mm while honeycomb was lighter compared to grid pattern. In brief, by comparing patterns, it was found out grid and honeycomb had the highest strength compared to other patterns based on stress, displacement, and weight. Moreover, 0° samples in both flat and on-edge direction had the strongest layer adhesion and the best quality. In contrast, perpendicular samples like 60° and 75° showed poor adhesion and were the weakest specimens in

both flat and on-edge, respectively. An issue was happened with 75° orientation sample in flat parts. The quality of part was like other perpendicular sample but the main problem was at the end of the printing process the machine could not adhere the layers properly and the material dropped or the binding was not good at all, therefore, this angle was removed due to this limitation, which might happen because of *poor* printing speed. In brief, this study says that by increasing the build orientation, the strength decreases. A total of 42 samples were printed by FDM machine for each orientation with a solid infill of 100%. In perpendicular samples, the machine used support structure to avoid the material drops. Thus, this may affect the surface texture and mechanical properties of final products.

*Atefeh Rajabi Kafshgar.et.al* [8] has done a paper on Optimization of properties for 3D printed PLA material using Taguchi, ANOVA, and multi-objective methodologies. This research work aims to provide insights on the influence of process parameters of FDM on mechanical properties of printed parts using DoE methods. In order to investigate the effect of process parameters on the tensile characteristics of 3D printed PLA material, some input model parameters including infill density from the range of 20 to 40%, extrusion temperature 200 – 220° C, raster angle from 0/90 and -45/45, and layer thickness 0.1 and 0.2 mm were considered as variable. Using the Taguchi optimization methodology and ANOVA the dependency of mechanical properties (such as ultimate tensile stress, yield strength, modulus of elasticity, toughness, and elongation at break) on the process parameters is studied. After conducting the experiment, it can be seen that “Infill Density” has a significant effect on all outputs. Raster angle and layer thickness have less effect on the UTS value. Moreover, the results show that besides infill density, layer thickness has a significant effect on elongation at break and toughness values as well. It is achievable from the results that increasing the infill density, extrusion temperature, and raster angle and decreasing layer thickness improves the UTS, modulus of elasticity, and yield strength of the PLA 3D printed tensile test sample. Thus, the best treatment combination for the UTS, modulus of elasticity, and yield strength is infill density of 60%, extrusion temperature of 220° C, and raster angle of 90°, and layer thickness of 0.1 mm. On the other side, the best treatment combination for elongation at break and toughness is obtained with an infill density of 60%, extrusion temperature of 200° C, raster angle of 45° and layer thickness of 0.2 mm. The result describes that 60% infill density is the best level of infill density parameter but there is no unique printing configuration that optimizes all mechanical properties.

They concluded by saying that UTS, modulus of elasticity, and yield strength had the same behavior when changing the levels of process parameters, and the highest level of them was noted at infill density of 60%, extrusion temperature of 220° C, raster angle of 90° and layer thickness of 0.1 mm. On the other hand, elongation at break and toughness had the same behavior, too. The highest levels of these two mechanical properties were obtained at an infill density of 60%, extrusion temperature of 200° C, raster angle of 45°, and layer thickness of 0.2 mm. Two of the conflicting responses i.e., UTS and toughness were considered simultaneously in the multi-objective model and Pareto solutions were obtained. Indeed, regression equations were extracted from the multi-objective analyses to obtain optimum values of both UTS and toughness in terms of the input parameters. The approach and the results of this paper can help in understanding the influence of the process parameters on five important mechanical properties of the FDM printed parts made of PLA material. **Jibisha et al [9]** has done a paper on the optimization of process parameters for improving mechanical strength of PLA plastics using taguchi method. The present study focuses on the process parameter effects for the rigidity of FDM part. Hence, two parameters such as infill density and printing pattern and three levels (80, 90, 100 and line, hexogen, triangle) are examined for the experimental model. L9 orthogonal array has been used for this project. The Poly Lactic Acid (PLA) material is used as filament in FDM process. The specimens are fabricated using FDM technology as per D638 standards. Using UTM machine. To maximize the tensile strength of FDM printed PLA parts MINITAB software is used concerned with optimization. The range analysis indicated that the optimal combination of tensile strength is hexagonal printing pattern and filling rate of 100%. From the above set of combination, the optimum tensile strength is obtained as 28.872 N/mm<sup>2</sup>. Comparing with normal varying filling ratio tensile specimen, the 100% filling ratio and hexagonal printing pattern tensile specimen has more tensile strength. The printing pattern is the most influencing parameter affecting the tensile strength of FDM specimens. **Mohammed et al [10]** has done the Investigation of tensile property-based Taguchi Method of PLA parts fabricated by FDM 3D printing technology. They have used 7 parameter to check tensile property, viz. Build orientation, Raster orientation, Nozzle diameter, Extruder temperature, Infill density, shell number and extruding speed. They have used L18 orthogonal array. They have selected bigger is better option in their result because tensile strength must be higher. They resulted that maximum Maximum tensile strength of 60.29 MPa was obtained with run 15, while minimum strength was 31.26 MPa obtained from the first run. Also, high strength was achieved in the runs

10–18, in these runs, the 3D printer creates the specimen in on-edge build orientation, so tensile strength is greatly affected by build orientation and its best level is on-edge orientation.

The results show that the optimum parameters are built orientation (on-edge), raster orientation (30/-60°), nozzle diameter (0.5 mm), extruder temperature (220° C), infill density (100%), shell number (3), and extruding speed (20 mm/s), with a maximum contribution of 44.68% for build orientation, and a minimum contribution 0.46% for raster orientation. According to the ANOVA table, only three parameters namely build orientation, nozzle diameter, and infill density were statistically significant. The optimal combination of the process parameters leads to a tensile strength of 58.05 MPa only 80% of material is used and the remaining 20% of the material and time is saved, so they is no need of using 100% of infill density. As a future work other tests such as flexural and impact, and morphology of the tested parts are recommended to highlight the properties of the fabricated parts by 3D printing technology, and this is part of our ongoing research.

**Raja. et.al.[11]** has done Optimization of 3D printing process parameters of polylactic acid filament based on the mechanical test. In this study, the research was made to optimize the printing parameters that can be used in the FDM production method to obtain the lowest production time and best printing parameter of PLA filament with the tensile test. The printing parameter that can be used in FDM machines such as extruder temperature, bed temperature, layer height, printing speed, travel speed, infill, and shell count is considered for optimization. In addition, the tensile specimens from American Society for Testing and Materials (ASTM) D638 standard were manufactured by PLA filament with the above-modified printing parameters. The best printing parameters for PLA products were found by the time recorded during production and tensile test results after production.

In this study they have printed the specimens (I, II, III, IV) with different parameters such as, extruder temperature(200° C, 210° C, 215° C, 217° C, 219° C), bed temperature(50° C, 60° C, 70° C, 80° C, 90° C), layer height (0.18,0.12,0.20,0.20,0.23) in mm, printing speed (60, 30, 70, 75, 55) mm/s, Travel speed (80,60, 90,80,70) mm/s, infill density (15,15,30,20,35) in %,infill pattern (hexagonal, line, triangle 35°, 3D infill, triangle 55°), shell count (2,3,2,3,3), time taken for fabrication(12, 18, 10, 8, 9) in minutes.

Specimen I can withstand weighs up to 750 N and shows the extension up to 13.56%, Specimen II can withstand weighs up to 650 N, and it shows an extension up to 10.909%, Specimen III can withstand weighs up to 650 N and shows the extension up to 13.850%, Specimen IV can withstand

weighs up to 550 N and shows the extension up to 10.974% and specimen V can withstand weighs up to 650 N and shows the extension up to 10.311%.

Specimen IV has the shortest time (8 minutes), and next, the specimen V can be produced in 9 minutes. Then, specimen III takes 10 minutes. Specimen I produced in 12 minutes and specimen II in 18 minutes. So, that concludes the specimen I withstands 13.573% longer extension and withstands the weighs 750 N than specimen III, specimen IV, and specimen V.

## 2.1 SUMMARY OF THE LITERATURE SURVEY:

The literature review surveyed on various printing parameters like Printing speed, infill density, Printing pattern, printing orientation, Bed temperature, nozzle Temperature, layer height, layer thickness, diameter of the nozzle, materials. The PLA was found to have more advantages than ABS, and PETG. It was found that the PLA temperature can be varied from 180-240 but 180 was eliminated due to its poor flow ability and 240 was eliminated because the filament melted into liquid. Hence, the perfect temperature was found between 190-230 and speed to be considered between 60-160 mm/s. The speed, Infill pattern, nozzle temperature, Infill density, Print orientation was found to be more influencing that other parameters. Hence, printing temperature, percentage of infill and shape of infill are the three different parameters considered during printing.

weighs up to 550 N and shows the extension up to 10.974% and specimen V can withstand weighs up to 650 N and shows the extension up to 10.311%.

Specimen IV has the shortest time (8 minutes), and next, the specimen V can be produced in 9 minutes. Then, specimen III takes 10 minutes. Specimen I produced in 12 minutes and specimen II in 18 minutes. So, that concludes the specimen I withstands 13.573% longer extension and withstands the weighs 750 N than specimen III, specimen IV, and specimen V.

## 2.1 SUMMARY OF THE LITERATURE SURVEY:

The literature review surveyed on various printing parameters like Printing speed, infill density, Printing pattern, printing orientation, Bed temperature, nozzle Temperature, layer height, layer thickness, diameter of the nozzle, materials. The PLA was found to have more advantages than ABS, and PETG. It was found that the PLA temperature can be varied from 180-240 but 180 was eliminated due to its poor flow ability and 240 was eliminated because the filament melted into liquid. Hence, the perfect temperature was found between 190-230 and speed to be considered between 60-160 mm/s. The speed, Infill pattern, nozzle temperature, Infill density, Print orientation was found to be more influencing that other parameters. Hence, printing temperature, percentage of infill and shape of infill are the three different parameters considered during printing.

**CHAPTER-3:**

**OBJECTIVES AND STATEMENT OF PROBLEM**

Based on the literature survey, following objectives are selected.

- To prepare 2D and 3D drawings of various test specimens using solid works software as per ASTM standards
- Selection of process parameters during FDM process.
- Use of L9 Orthogonal array to select the combination to print.
- Fabricate the Tensile and Compression test specimen using FDM process.
- Testing the prepared specimens and tabulating the results.
- Concluding the best combination based on obtained results.

## STATEMENT OF THE PROBLEM

As the parts created by AM especially PLA has many advantages and can be used in various applications. In this project an attempt has been made to evaluate the mechanical properties of 3D printed PLA material with various process parameters. Based on the results obtained, it is concluded the best combination which provides higher strength. Here an attempt is also made to use the concept of Design of Experiments (DoE) a Taguchi approach to select the combination of printing parameters during the preparation of test specimens.

## CHAPTER-4:

## METHODOLOGY

Based on the selected objectives, the step involved in carrying out the present project is represented in Fig. 4.1.

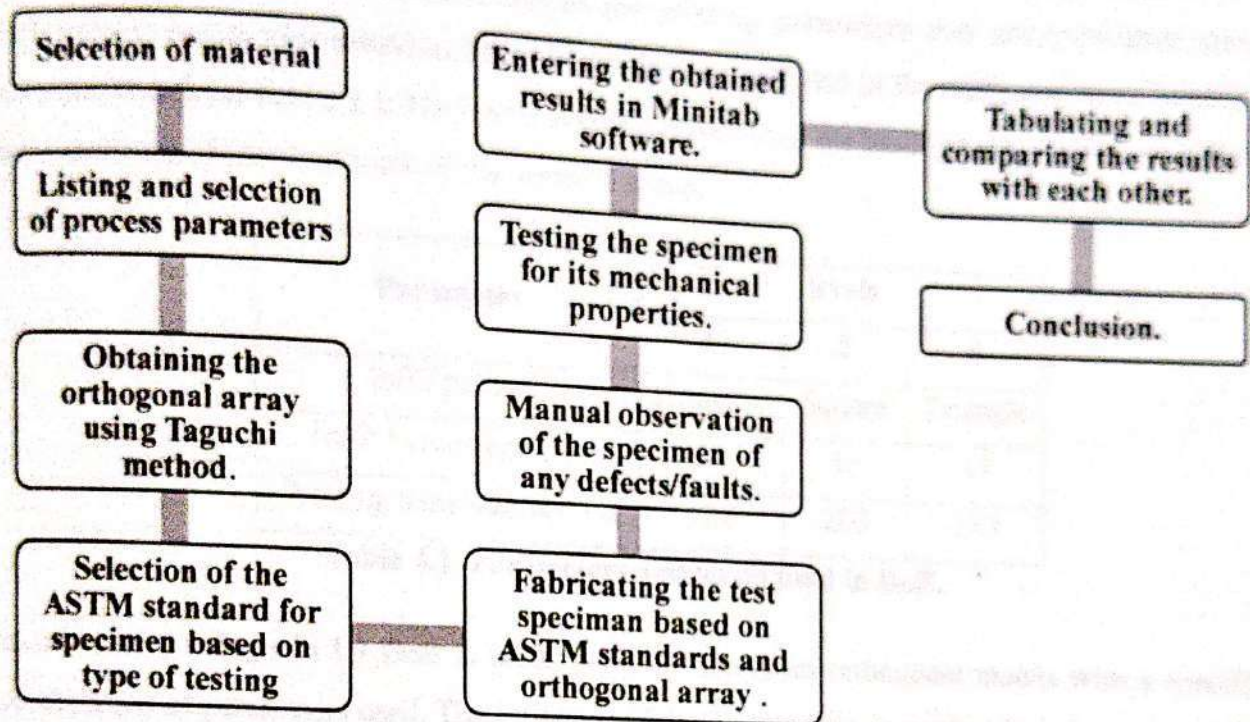

Fig. 4.1 Steps involved in present work.

Based on the detailed literature review and cost of materials, in the present project PLA material is selected and testing of mechanical properties is carried out for PLA printed with different printing parameters obtained from DoE.

#### 4.1. SELECTION OF PRINTING PARAMETERS:

Various printing parameters are available in CURA slicing software like layer height, base top and wall thickness, printing and bed temperature, Infill percentage and infill shapes, angle of print ect. Among all the printing variables based on the literature survey, in the present project printing parameters are printing temperature in degree celsius, infill shape and percentage is selected. All the three parameters are Printing temperature is varied from 190 to 210° C in the step of 10° C. three different infill shape of Tri- Hexagon (Hexagon), Square (Grid) and Triangle.

Infill percentage varying from 25% to 45% in the step of 10%. In most of the literature work has been carried for infill percentage only for higher percentage. Here an attempt is made to study the effect of lower infill percentage.

#### 4.2. DESIGN OF EXPERIMENTATION - TAGUCHI EXPERIMENTAL DESIGN:

To carry out the mechanical property study, the design of experiments (DOE) technique was used. The design consists of the combination of the printing parameters that are considered most influential in mechanical behavior. Three parameters are included in the study, and three levels of each one is defined Table. 3.1. They were selected considering the bibliography studied, as well as the experience of previous work of the research group.

Parameter	levels		
	1	2	3
Infill pattern	Hexagon	Square	Triangle
Infill Percentage (%)	25	35	45
Printing temperature (°C)	190	200	210

Table 4.1. Parameters and levels used in DoE.

In this study, a Taguchi L9 DoE is used. Table 3.2 shows an orthogonal matrix with a specific combination of parameters used. The influence of these separately as well as their interaction will be studied.

Nº	Infill pattern	Infill Percentage (%)	Printing temperature(°C)
1	Hexagon	25	190
2	Hexagon	35	200
3	Hexagon	45	210
4	Square	25	200
5	Square	35	210
6	Square	45	190
7	Triangle	25	210
8	Triangle	35	190
9	Triangle	45	200

Table. 4.2. Orthogonal matrix of Taguchi L9 for the DOE.

### 4.3 MANUFACTURING OF SPECIMENS:

The design of the specimens used in the study was done with SOLIDWORKS software as per ASTM standards, and the models were filled with Cura software. Subsequently, they were manufactured in the domestic 3D printer, INVI S20 Single Extruder. Their geometry of the test specimen is shown in Fig. 3.2 with dimensions according to the standard that governs the tensile test.

All manufactured specimens were tested in lab, in which they were weighed and measured with a caliper. Therefore, they had to be validated before testing from a dimensional and constructive point of view. The resulting lengths, widths, and weights were statistically processed, and those specimens whose descriptors were out of the  $\pm 2\%$  were considered not to comply and were immediately discarded.

### 4.4 PRINTING MATERIAL:

The material used in the manufacture of the specimens is as discussed below. Properties of PLA materials used in 3D printing process is mentioned in Table 3.3.

Mechanical Property	Value
Yield strength	60 MPa
Elongation at break	6%
Tensile modulus	3600 MPa
Flexural strength	83 MPa
Flexural modulus	3800 MPa

Table.4.3. shows the properties of PLA Material.

The parameters selected for this project viz. printing speed, nozzle temperature, infill density, pattern will be changing according to the 9 combinations. Table. 3.4 shows printing time and amount of material used for printing each test specimen.

N <sup>o</sup>	Infill pattern	Infill Percentage (%)	Printing temperature (°C)	PLA material consumed (gms)	Printing time (min)
1	Hexagon	25	190	9	56
2	Hexagon	35	200	10	58
3	Hexagon	45	210	11	64
4	Square	25	200	9	50
5	Square	35	210	10	53
6	Square	45	190	13	62
7	Triangle	25	210	10	49
8	Triangle	35	190	11	54
9	Triangle	45	200	12	50

Table. 3.4. Material used and printing time.

#### 4.5 PRINTING OF TEST SPECIMEN:

Once the arrangement of specimen's and entering of the input values is completed in the Ultimaker cura. File is saved with appropriate name after providing print variables. In this study infill shape, percentage of infill and printing temperature is varied as per the objectives. Other parameters selected in cura is shown in Table. 3.5.

Sl. No	Profile	Draft
1.	Layer height	0.2 mm
2.	Wall thickness	0.8 mm
3.	Wall line count	2
4.	Horizontal expansion	0
5.	Top thickness	0.8 mm
6.	Bottom thickness	0.8 mm
7.	Top layer	4
8.	Bottom layer	4
9.	Build plate temperature	60°C
10.	Fan speed	100%
11.	Build adhesion type	Skirt

Table. 4.5. Various print parameters in Cura software.

When the file is saved, it will automatically generate the G-code. Select this file and transfer it to the printing machine through the means of SD card. Then SD card is installed into 3D printing machine, and the test specimen is printed.

In this project we have used the INVIS20 is used for printing the specimen. It is 3D printer which use the FDM process to print the specimens. The Fig. 3.2 shows the INVIS20 printer and Table. 3.6. shows the specifications of INVIS20 printer.

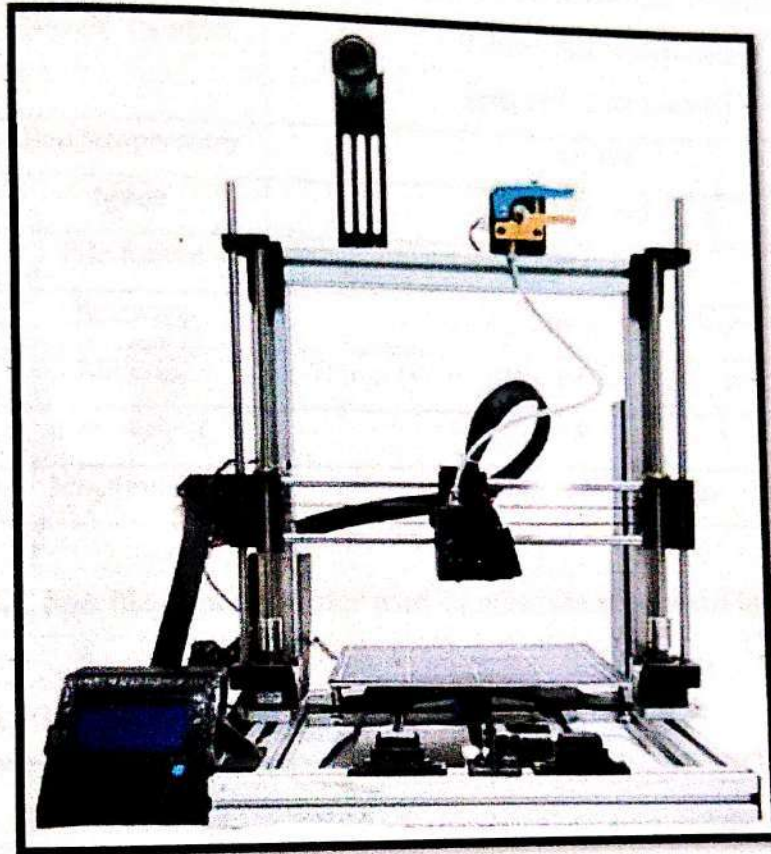

Fig.4.2 INVIS20 Printer

Printing of test specimens are carried out the Invihub Pvt. Ltd, Rajajinagar, Bangalore. Fig. 3.3 shows the images of tensile and compression test specimens.

Sl. No	Particulars	Specifications
1.	Model name	INVI S20
2.	Build size	220*220*250mm
3.	Printing resolution	±0.1mm
4.	Printing speed	60mm/s
5.	Nozzle diameter	Recommended (can be 80mm.s) 0.4mm Recommended (can be 0.2 to 0.6mm)
6.	Bed temperature	<100°C
7.	Mode	SD card
8.	File format	STL, .obj
9.	Software	CURA, Simplify3d, Slicer
10.	Material	1.75mm (PLA, ABS, PETG, TPU, Wood and PLA)
11.	Net weight	8.7kg
12.	Machine size	470*390*350mm

Table. 4.6. Specification of printer used to print the specimens in this study.

Fig.4.3 a) Tensile test specimen :

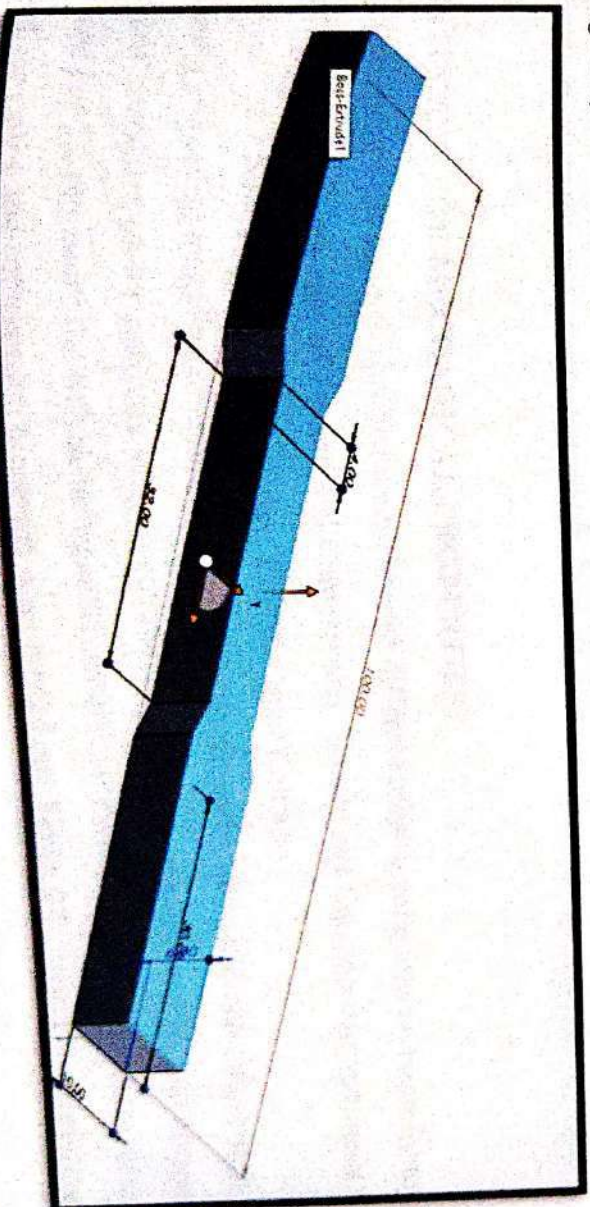

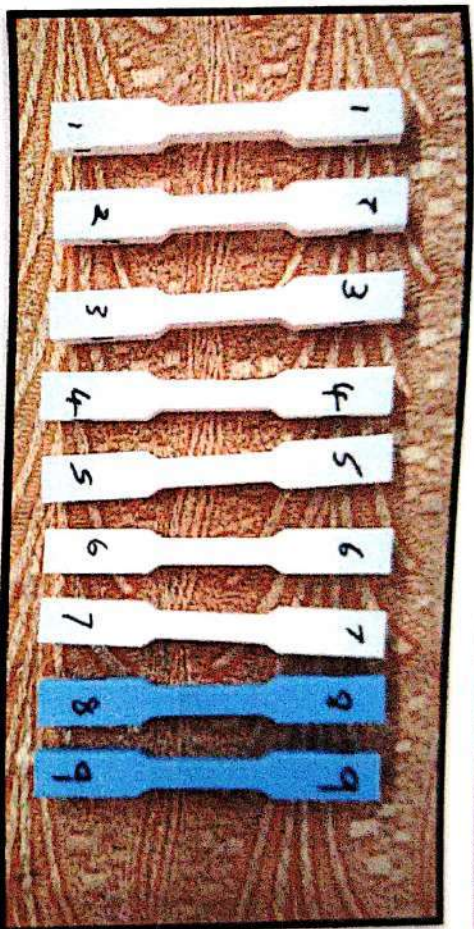

b) Compression test specimen

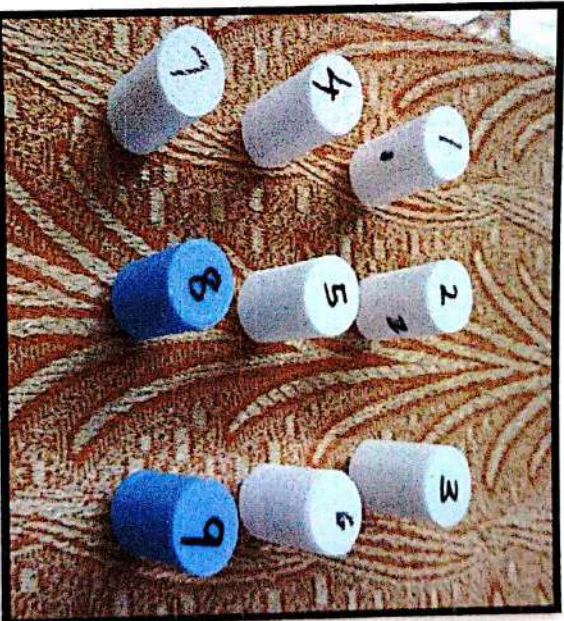
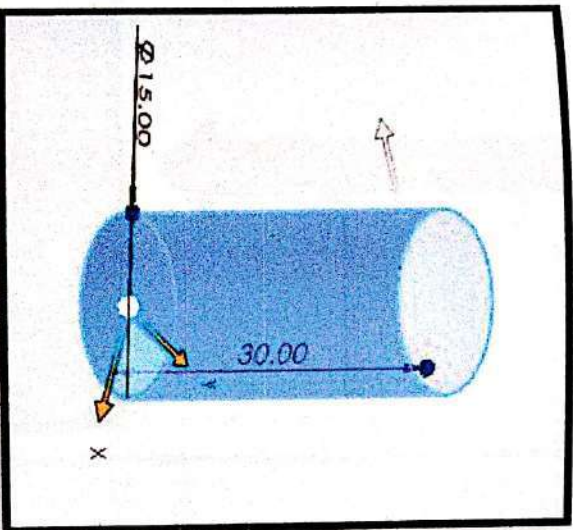

#### 4.6 TESTING FOR MECHANICAL PROPERTIES:

Once the printing is done, the printed specimen with different printing parameters is taken for testing the Mechanical Properties of Tensile and Compression. Tensile and Compression tests have been carried out at S.J.C Institute of technology, Chickballapur College

Tensile properties, including modulus, yield and tensile strengths, and yield and failure strain are widely characterized for purposes such as comparison of alloys, quality control, and component model Fig. 3.4 represents the Kalpak instruments and control's universal testing machine, in which both the tensile and compression properties were carried out. Table. 3.7. Portray the specifications of testing machine.

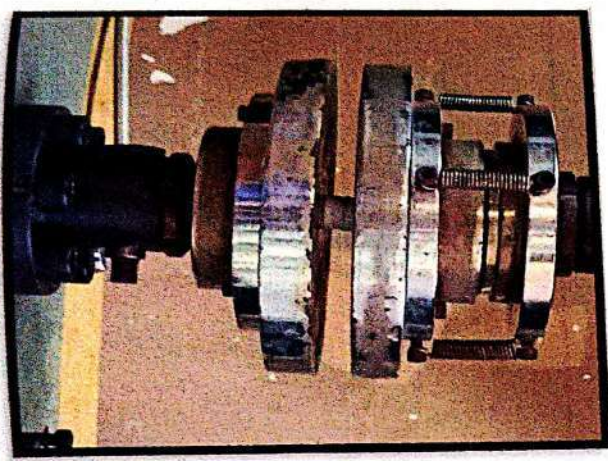
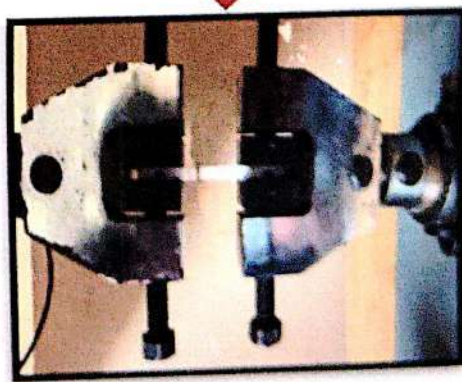
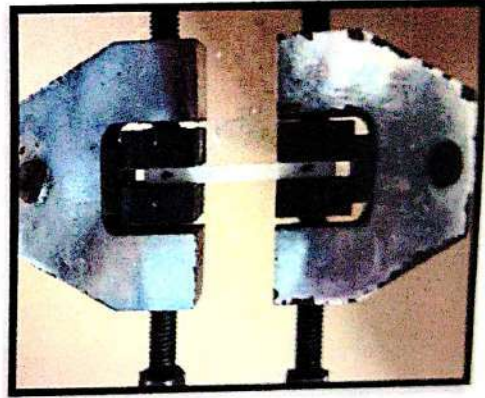
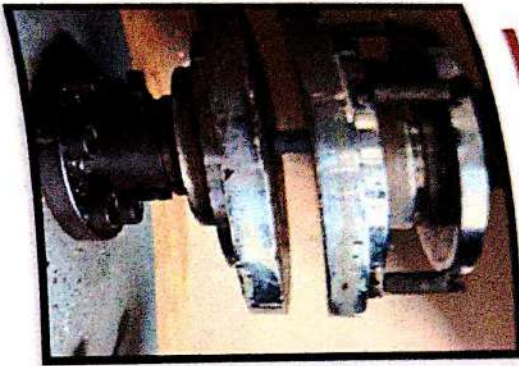

Fig. 4.4. Testing of specimen.

MODEL NO.	KTC-2000X-C
Maximum Capacity	50 KN, 75 KN, 100 KN, 150 KN, 250 KN
No. of Load Cells	Up to 16
Ball Screw	Double Ball Screw with bellows
Mounting	Free Standing
Load Resolution	0.01%
Load Accuracy	+/-0.5% of Reading over 2% to 98% capacity
Length Resolution	For Crosshead Travel 0.01mm
Length Accuracy	0.1mm
Cross head Speed	Up to 100mm/min
Speed Resolution	Min. up to 0.01mm
Cross head Travel	500/800/1000/1500 mm as per requirement.
Min. Distance between Grips	0 mm
Side Clearance	At least 400 mm
Front to back clearance	Unlimited
Actuator Drive	Digital AC Servo Drive with Servo Motor
Control Mechanism	Computerized Controller with dedicated software. Add on cards for control in both Auto & Manual mode
PC Configuration	Pentium IV 2.6 GHz, with 52X CD-R RW, 256MB RAM, 40GB HDD, Mouse, Keyboard, 1 SERIAL COM port, 2 USB ports, 1 printer port, with WINDOWS XP professional preloaded
Grips & Fixtures	Mechanical Pneumatic Wedge Grips, Screw Type Grip, Eccentric Roller, Compression Plates, 3 point bending fixture, Peel test 90° 180 Degree Fixture, Lateral Ball Withdrawal/Fixture, Fixtures for Flexural test, Shear Test, Adhesion/Bonding Strength etc.
Accessories	Extensometers, Additional Load Cells, Hot Air circulation Chamber
Units	Metric, Imperial & SI User Programmable
Power Supply	220 Vac, 50 Hz, 300 VA
Size	1800 (H) x 950 (W) x 600 (D) mm approx

Table. 4.7. Specification of the Kalpak Universal testing machine.

When the compression testing is to be done in this machine, only the jaws need to be replaced. Both the input and output of the machine is controlled by computer and each data will be loaded inside it to generate the results of the test carried out in it. Fig. 3.5 and 3.6 shows the tensile and compression test specimens after completion of tests.

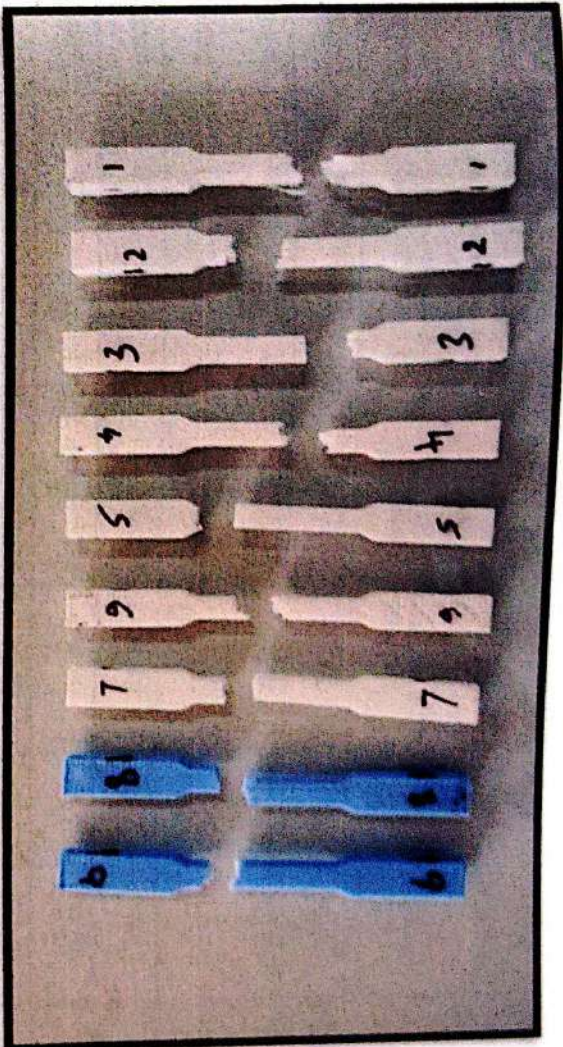

Fig. 4.5 Broken specimen of Tensile.



Fig. 4.6 Broken specimen of compression.

Once the testing is completed, results are obtained automatically. Table. 3.8 and Table. 3.9. Shows the results obtained from the universal machine for tensile and compression test respectively.

No	Infill pattern	Infill Percentage (%)	Printing temperature (°C)	Peak load (N)	% Elongation	Break Load (N)	UTS (N/mm <sup>2</sup> )	Youngs Modulus (N/mm <sup>2</sup> )
1	Hexagon	25	190	284.00	4.10	2.77	8.17	199.62
2	Hexagon	35	200	537.00	3.66	347.35	15.43	421.58
3	Hexagon	45	210	585.00	3.68	347.35	16.81	457.15
4	Square	25	200	501.00	5.52	1.83	14.39	260.76
5	Square	35	210	542.00	4.45	3.55	15.57	349.84
6	Square	45	190	313.00	4.99	18.15	0.00	180.30
7	Triangle	25	210	566.00	4.40	443.77	16.26	369.80
8	Triangle	35	190	515.00	3.73	495.97	14.80	396.59
9	Triangle	45	200	430.00	3.05	23.06	12.34	405.06

Table. 4.8 Result of Tensile test.

Compressive testing shows how the material will react when it is being compressed. Compression testing can determine the material's behavior or response under crushing loads and to measure the plastic flow behavior and ductile fracture limits of a material. For the compression properties, Table. 3.9. represents the numeric values of Peak load in N, % of elongation, Break load in N and compressive strength in N/mm<sup>2</sup>.

No	Infill pattern	Infill Percentage (%)	Printing temperature (°C)	Peak load (N)	% Compression	Break Load (N)	Compressive strength (N/mm <sup>2</sup> )
1	Hexagon	25	190	428.00	24.25	24.57	3.37
2	Hexagon	35	200	1050.00	41.74	25.50	8.28
3	Hexagon	45	210	993.00	14.78	45.04	7.84
4	Square	25	200	982.00	22.01	23.76	7.75
5	Square	35	210	643.00	32.13	27.02	5.07
6	Square	45	190	1919.00	19.00	27.02	15.14
7	Triangle	25	210	685.00	28.26	1.35	5.41
8	Triangle	35	190	883.00	32.19	1.35	6.97
9	Triangle	45	200	1173.00	20.56	0.68	9.26

Table. 4.9 Result of compression test.

All these results were noted down for the further results. Once the results of Table 8 and 9 were obtained, these readings are again fed to the Mini Tab software to get the final results i.e. which combination has the higher results and which parameters contributes more compared to other combinations. After putting these values into the software, we got the results as explained in the Results and discussion chapter.

**CHAPTER-5:****RESULTS****Process Optimization**

The signal to noise (S/N) ratio is used to denote the changes in goal value in response to diverse noise conditions. A higher value for the S/N ratio represents better settings of the control variables that diminish the influence of the noise variables. The minimization of influence of noise variables on the experiments can be achieved by maximizing the S/N. Since the objective of this study is the maximization of the mechanical properties, an equation with the-greater-the-better feature was adopted for the analysis. The variation in the tensile strength of the printed PLA parts due to various factors was assessed in accordance with the Taguchi method.

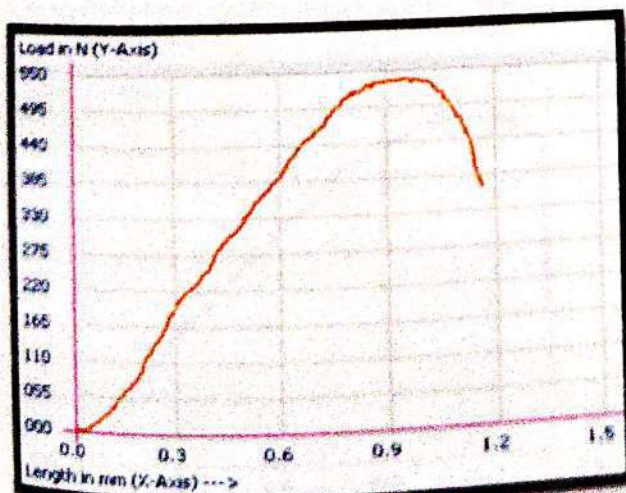
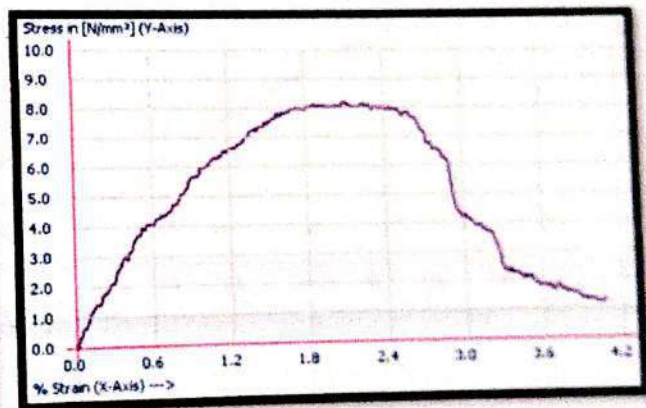
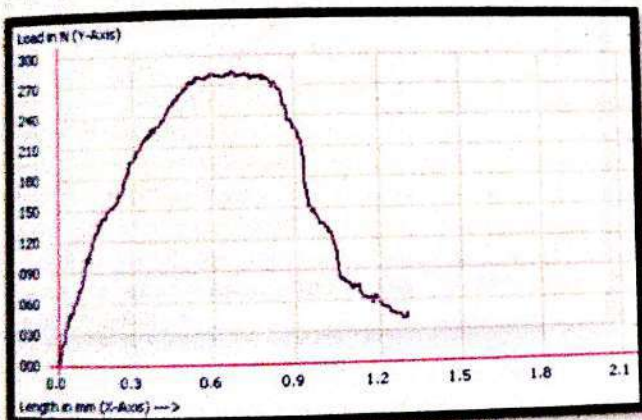
**5.1. RESULT OF TENSILE TEST:**

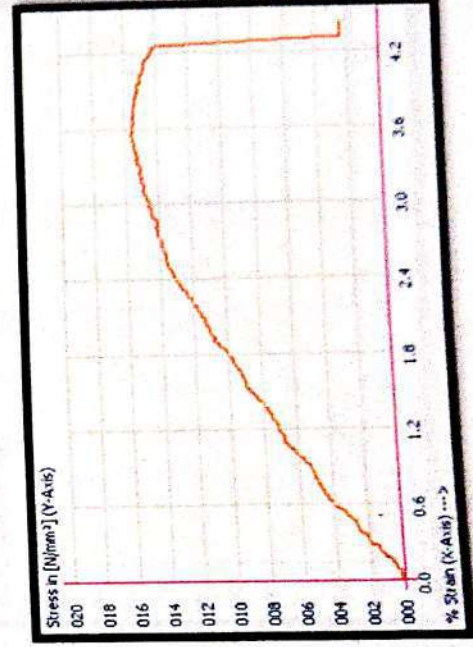
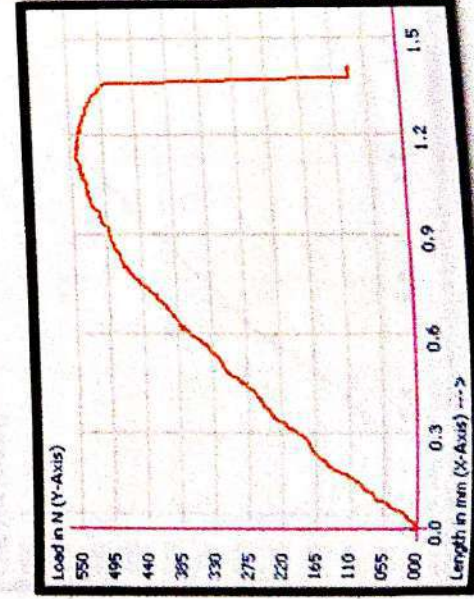
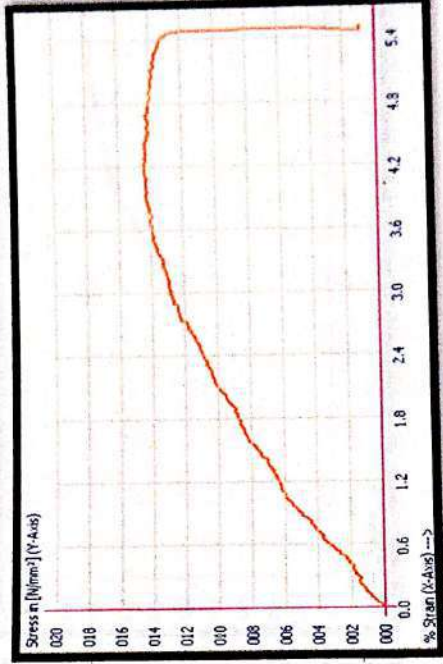
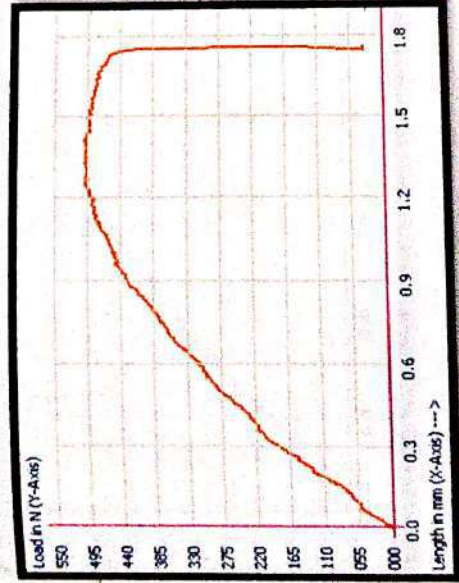
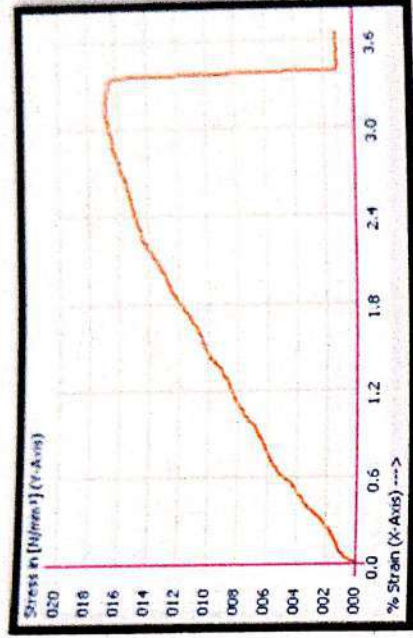
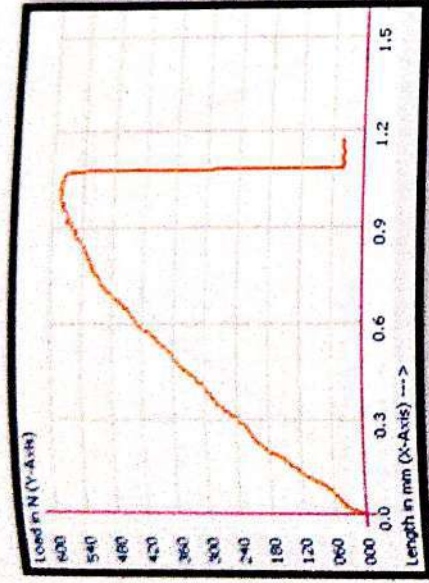

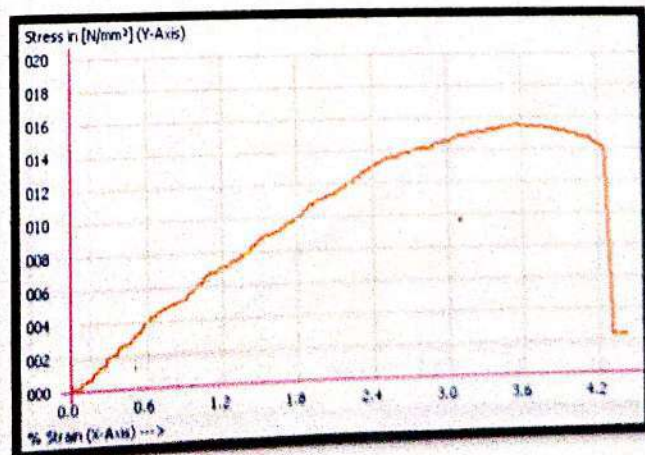
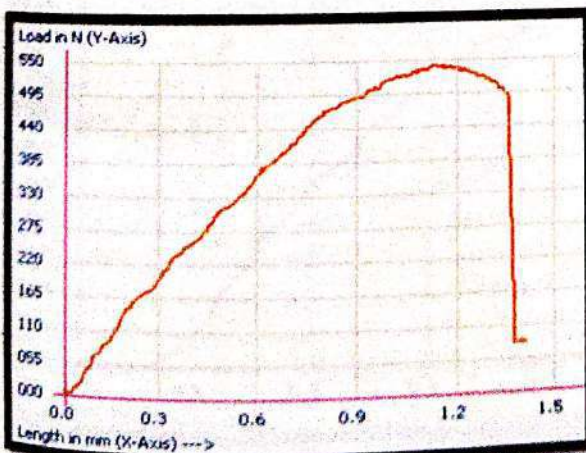
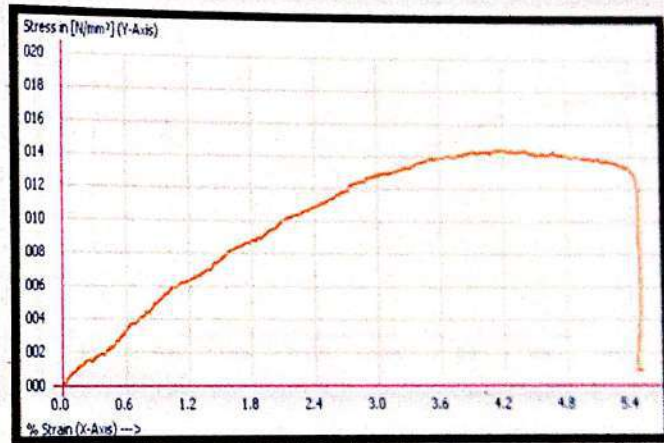
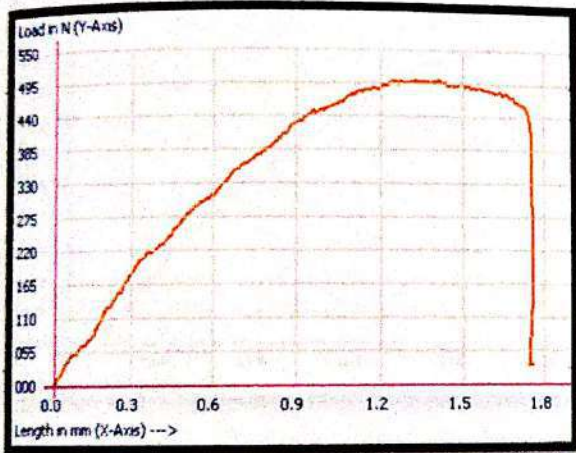
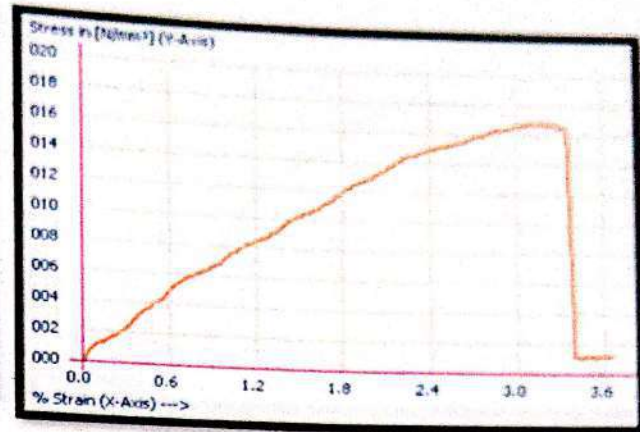
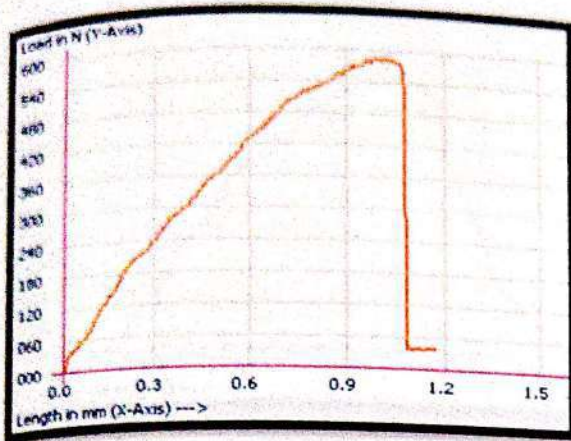

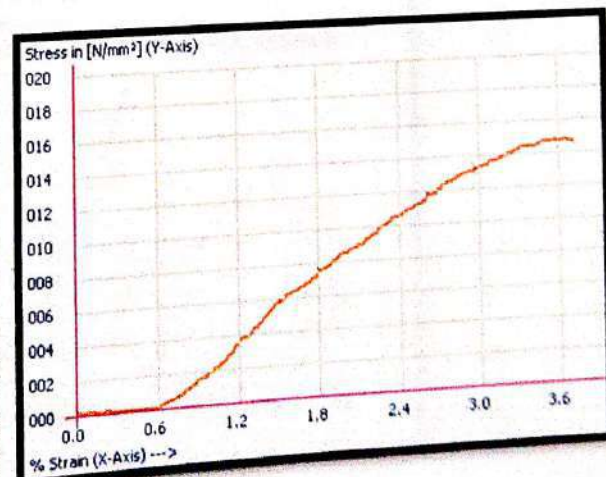
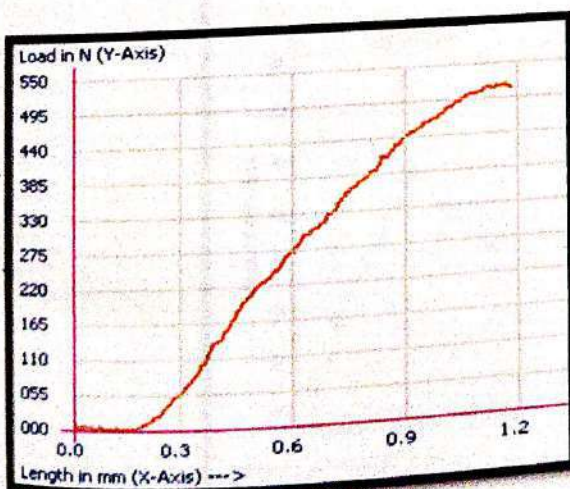
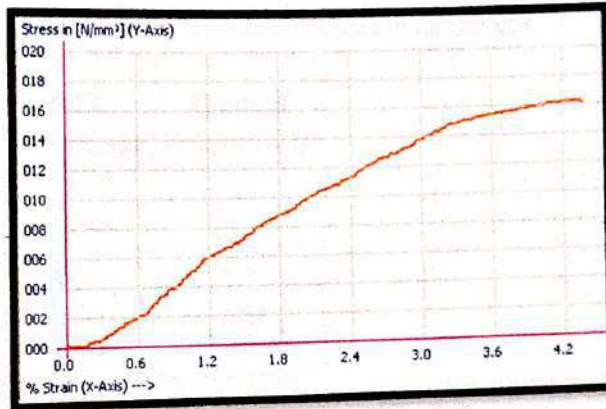
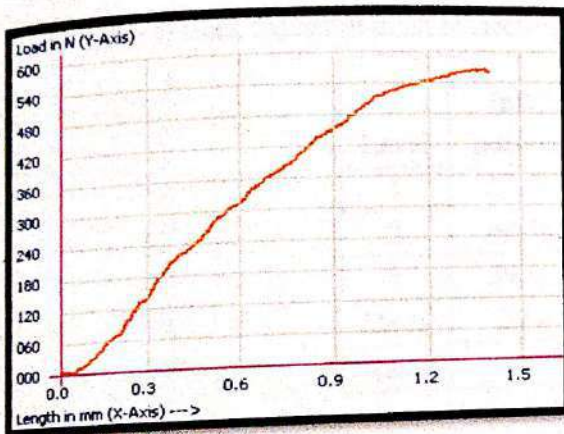
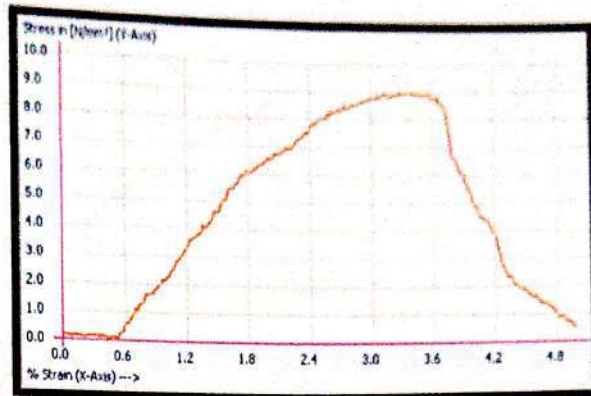
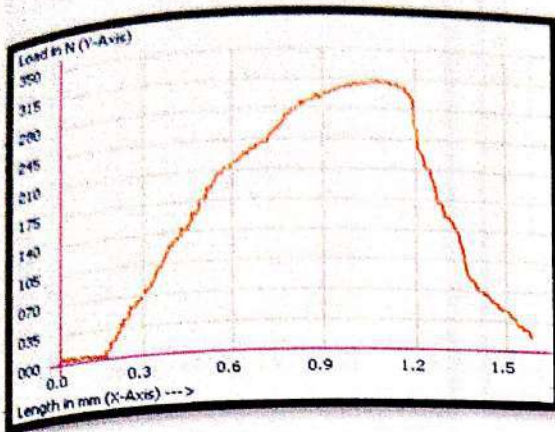

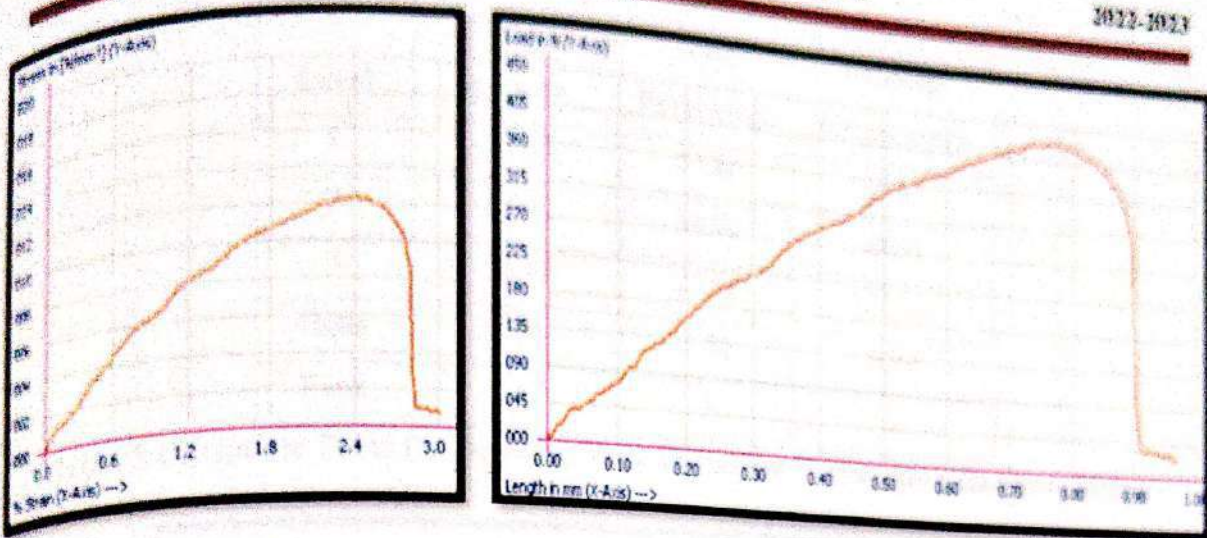

Fig. 5.1, 5.2, 5.3 and 5.4 shows the main effect plots for the 3D-printed tensile test parts for peak load, % elongation, break load and UTS respectively. Table 5.1, 5.2, 5.3 and 5.4 shows the order of rank that influence the result most respectively. All the results are related to tensile specimens.

Level	Infill pattern	Infill Percentage	Printing temperature
1	57.66	56.39	59.07
2	60.56	58.50	60.55
3	59.01	62.33	57.61
Delta	2.89	5.93	2.94
Rank	3	1	2

Table. 5.1. Response Table for Signal to Noise Ratios for Peak load (larger is better)

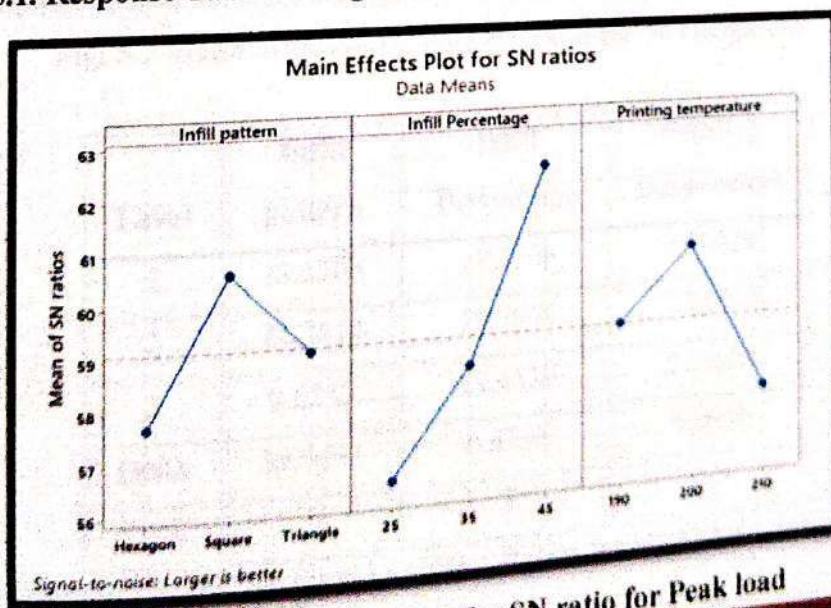

Fig. 5.1 Mean effective plot for SN ratio for Peak load

Level	Infill pattern	Infill Percentage	Printing temperature
1	27.83	27.86	27.81
2	27.52	30.90	28.51
3	28.48	25.08	27.52
Delta	0.96	5.82	0.99
Rank	3	1	2

Table. 5.2 Response Table for Signal to Noise Ratios for % elongation (larger is better)

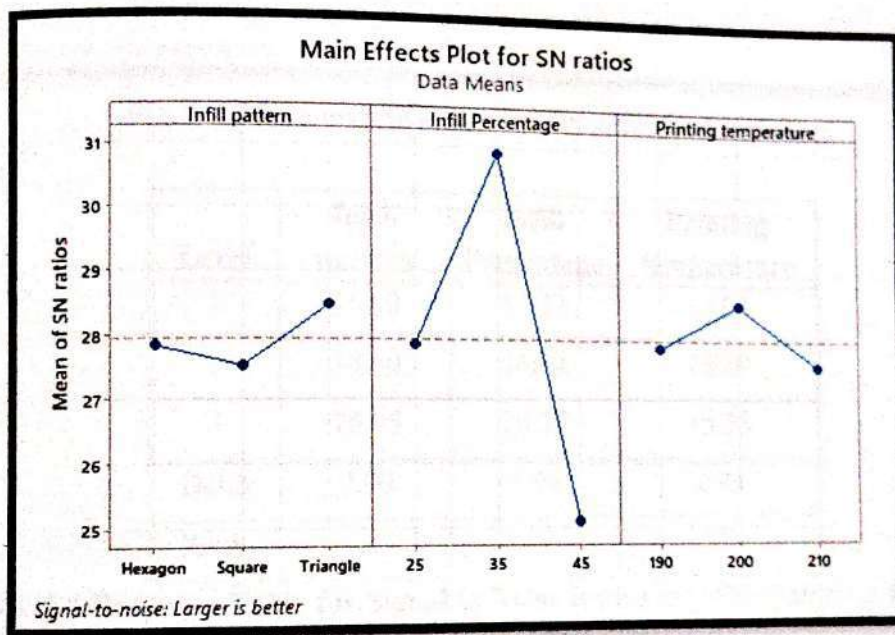

Fig. 5.2 Mean effective plot for SN ratio for % elongation

Level	Infill pattern	Infill Percentage	Printing temperature
1	29.6703	19.3106	19.6828
2	28.2614	19.7904	17.4326
3	0.6212	19.4520	21.4374
Delta	29.0491	0.4798	4.0048
Rank	1	3	2

Table. 5.3 Response Table for Signal to Noise Ratios for break load (larger is better)

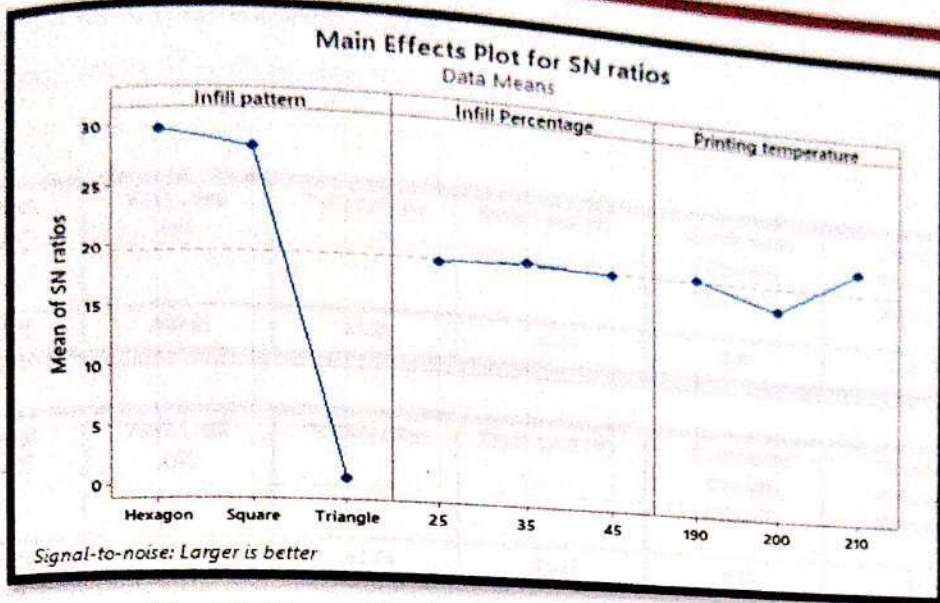

Fig. 5.3 Mean effective plot for SN ratio for break load

Level	Infill pattern	Infill Percentage	Printing temperature
1	15.60	14.33	17.01
2	18.50	16.44	18.49
3	16.95	20.27	15.55
Delta	2.90	5.94	2.94
Rank	3	1	2

Table. 5.4 Response Table for Signal to Noise Ratios for UTS (larger is better)

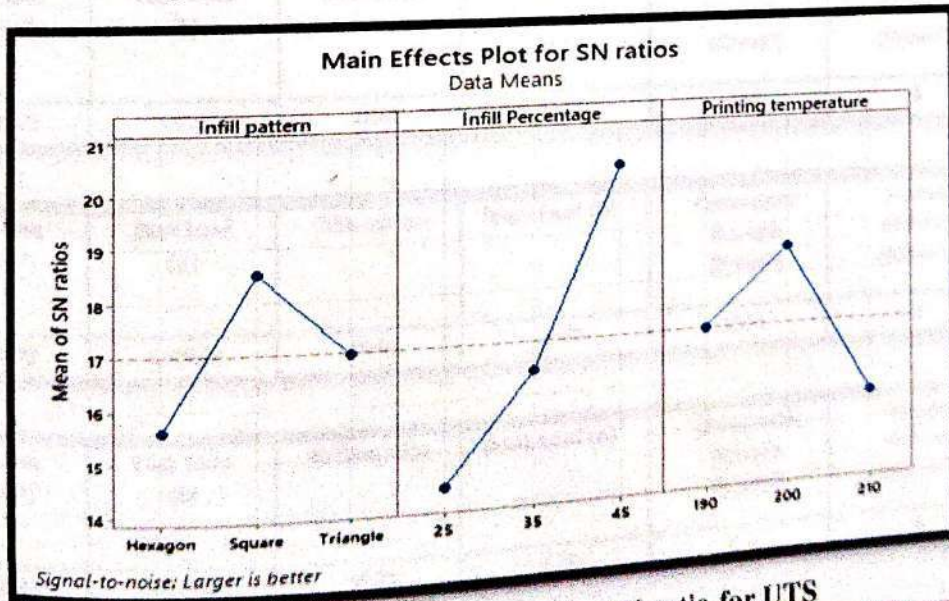

Fig. 5.4 Mean effective plot for SN ratio for UTS

## 5.2 RESULTS OF COMPRESSION TEST:

In this section, results of compression test are shown.

CS Area (mm <sup>2</sup> )	Peak Load (N)	%Elongation	Break Load (N)	Compressive Strength (N/mm <sup>2</sup> )	Youngs Modulus (N/mm <sup>2</sup> )
126.73	428.00	24.25	24.57	3.37	0

CS Area (mm <sup>2</sup> )	Peak Load (N)	%Elongation	Break Load (N)	Compressive Strength (N/mm <sup>2</sup> )	Youngs Modulus (N/mm <sup>2</sup> )
126.73	1,050.00	41.74	25.50	8.28	0

CS Area (mm <sup>2</sup> )	Peak Load (N)	%Elongation	Break Load (N)	Compressive Strength (N/mm <sup>2</sup> )	Youngs Modulus (N/mm <sup>2</sup> )
126.73	993.00	14.78	45.04	7.84	0

CS Area (mm <sup>2</sup> )	Peak Load (N)	%Elongation	Break Load (N)	Compressive Strength (N/mm <sup>2</sup> )	Youngs Modulus (N/mm <sup>2</sup> )
126.73	982.00	22.01	23.76	7.75	0

CS Area (mm <sup>2</sup> )	Peak Load (N)	%Elongation	Break Load (N)	Compressive Strength (N/mm <sup>2</sup> )	Youngs Modulus (N/mm <sup>2</sup> )
126.73	643.00	32.13	27.02	5.07	0

CS Area (mm <sup>2</sup> )	Peak Load (N)	%Elongation	Break Load (N)	Compressive Strength (N/mm <sup>2</sup> )	Youngs Modulus (N/mm <sup>2</sup> )
126.73	1,919.00	19.00	27.02	15.14	0

CS Area (mm <sup>2</sup> )	Peak Load (N)	%Elongation	Break Load (N)	Compressive Strength (N/mm <sup>2</sup> )	Youngs Modulus (N/mm <sup>2</sup> )
126.73	685.00	28.26	1.35	5.41	0

CS Area (mm <sup>2</sup> )	Peak Load (N)	%Elongation	Break Load (N)	Compressive Strength (N/mm <sup>2</sup> )	Youngs Modulus (N/mm <sup>2</sup> )
126.73	883.00	32.19	1.35	6.97	9

CS Area (mm <sup>2</sup> )	Peak Load (N)	%Elongation	Break Load (N)	Compressive Strength (N/mm <sup>2</sup> )	Youngs Modulus (N/mm <sup>2</sup> )
126.73	1,173.00	20.56	0.68	9.26	9

Fig. 5.5, 5.6 5.7 and 5.8 shows the main effect plots for the 3D-printed compression test for peak load, % compression, break load and Compression strength respectively. Table 5.5, 5.6, 5.7 and 5.8 shows the order of rank that influence the result most respectively. All the results are related to compression specimens.

Level	Infill pattern	Infill Percentage	Printing temperature
1	57.66	56.39	59.07
2	60.56	58.50	60.55
3	59.01	62.33	57.61
Delta	2.89	5.93	2.94
Rank	3	1	2

Table. 5.5 Response Table for Signal to Noise Ratios for peak load (larger is better)

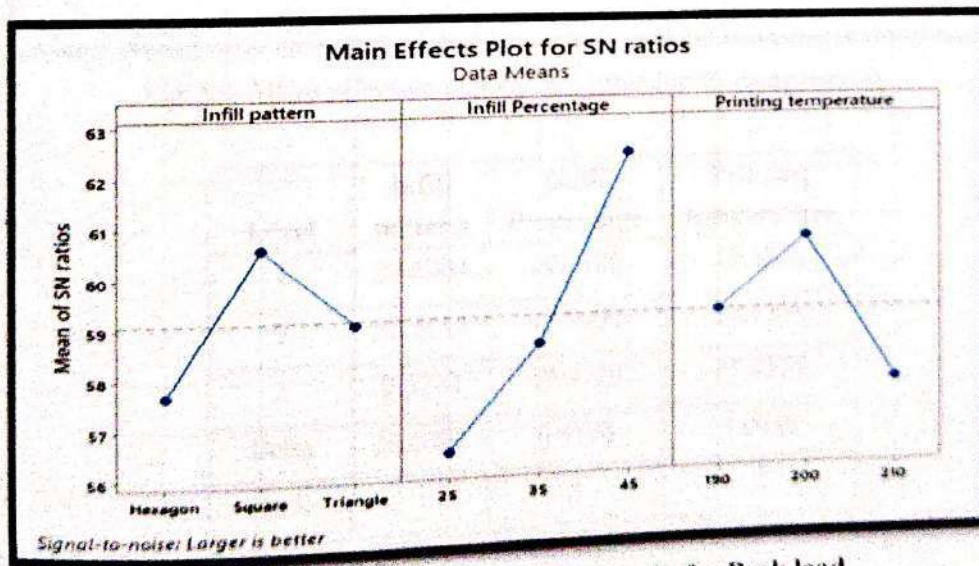

Fig. 5.5 Mean effective plot for SN ratio for Peak load

Level	Infill pattern	Infill Percentage	Printing temperature
1	-27.83	-27.86	-27.81
2	-27.52	-30.90	-28.51
3	-28.48	-25.08	-27.52
Delta	0.96	5.82	0.99
Rank	3	1	2

Table. 5.6 Response Table for Signal to Noise Ratios for % compression (larger is better)

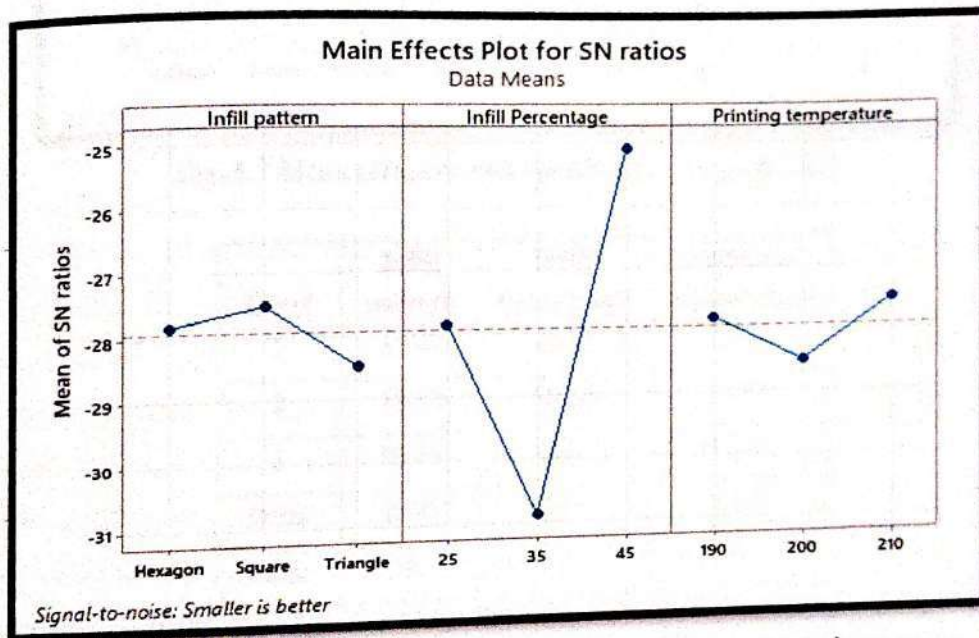

Fig. 5.6 Mean effective plot for SN ratio for % compression

Level	Infill pattern	Infill Percentage	Printing temperature
1	29.6703	19.3106	19.6828
2	28.2614	19.7904	17.4326
3	0.6212	19.4520	21.4374
Delta	29.0491	0.4798	4.0048
Rank	1	3	2

Table. 5.7 Response Table for Signal to Noise Ratios for Break load (larger is better)

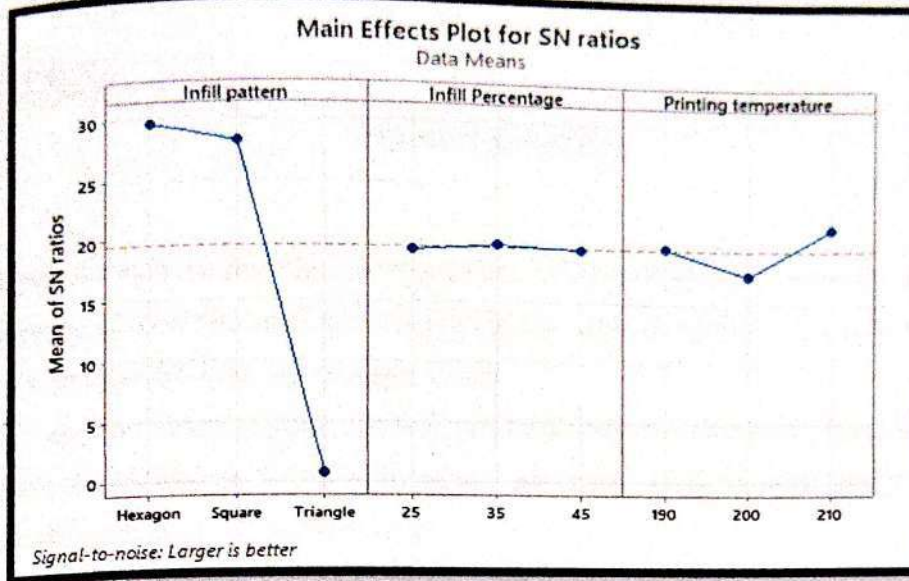

Fig. 5.7 Mean effective plot for SN ratio for peak load

Level	Infill pattern	Infill Percentage	Printing temperature
1	15.60	14.33	17.01
2	18.50	16.44	18.49
3	16.95	20.27	15.55
Delta	2.90	5.94	2.94
Rank	3	1	2

Table. 5.8 Response Table for Signal to Noise Ratios for Compressive strength (larger is better)

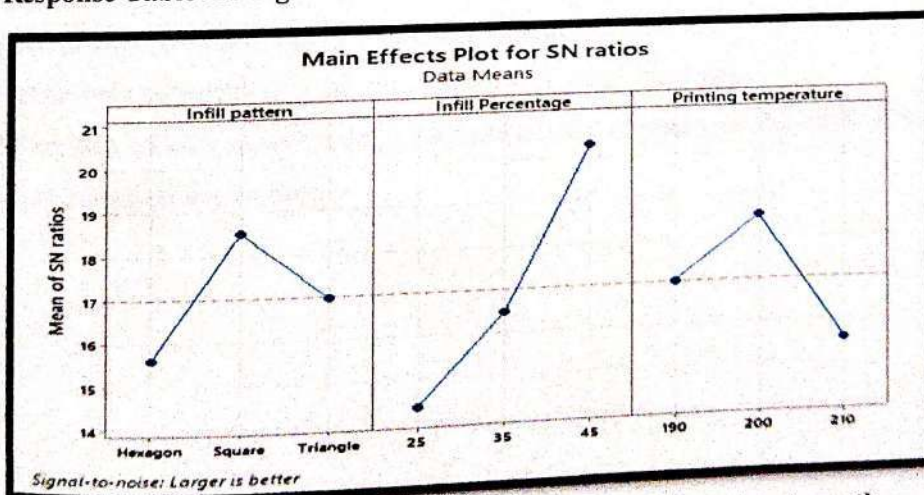

Fig. 5.8 Mean effective plot for SN ratio for compressive strength

**CHAPTER-6:****CONCLUSION**

In this project, we have successfully investigated the influence of diverse processing parameters on the 3D printing of PLA test specimen, employing the Taguchi approach. The following are the conclusions obtained from the experimental results:

Among the variables in this analysis, the infill pattern is found to be the most important parameter affecting the tensile strength of the PLA printed specimens, while the infill density is the key parameters affecting the compressive strength.

The Hexagon pattern with a printing temperature of 210°C and infill density of 45% shows the highest peak load of 585N, whereas hexagon pattern with printing temperature of 190°C and a infill density of 25% shows the lowest peak load of 284N. This is may be attributed to least infill density leads large gap between the infills and tends to reduced bonding. As the percentage of infill increases, load carrying capacity also increase. Shape of infill for both highest and lowest peak load in hexagon which tends to remains same. This result reveals that, there is much influence of printing temperature and infill density on peak load carrying capacity of the specimen.

In the case of % of elongation, highest percentage of elongation is observed as 4.99 and lowest is for 3.05 for square infill pattern, with infill percentage of 45% having print temperature of 190°C and triangular infill with 45% by printing temperature at 200°C respectively, this may be attributed due to square pattern provides more ponding than triangular pattern.

Similar trends were observed in break load, UTS and Young's modules.

Higher fill density indicates a higher degree of compactness of plastic on the inside of the print, and as a result a stronger printed object.

**CHAPTER-7:****SCOPE FOR FUTURE WORK**

The same experiment can be carried out for various parameters such as layer height, bed temperature, print orientation, wall thickness etc. Where we have kept that constant in this study. Varying these parameters may lead to better results for the same chosen material ie, PLA. The Mechanical Strength can be better with varying these parameters also.

We can also use Higher Orthogonal Array rather than L9 like L16 and L32 which leads to more possible combinations. These results obtained from higher orthogonal array may provide more precision and accurate results.

By reinforcing different materials into PLA instead of PLA alone like Carbon Fiber, Bamboo, wood, ABS, PET-G is the most interested analysis where one can work on. These may lead to the higher mechanical strength than obtained for PLA alone. Other mechanical properties and thermal like impact, wear, torsion bending and conductivity can be evaluated.

## REFERENCES

1. Todd letcher and Megan waytasek, 2014, south Dakota state university, USA.
2. Chris D. McCooy- June 27 to July 1, 2016 University of California, Blacksburg, USA.
3. R. Surendra & S. Pushpa Nandini, 2021 Govt. College of Technology, Coimbatore, Tamil Nadu.
4. Alexey n. solonin & Richard schilling, 2018 national university of science and technology, Moscow, Russia.
5. A. Pandzic, D. Hodzic, and A. Milovanovic, "Effect of Infill Type and Density on Tensile Properties of PLA Material for FDM Process," in DAAAM Proceedings, 1st ed., vol. 1, B. Katalinic, Ed. DAAAM International Vienna, 2019, pp. 0545-0554. doi: 10.2507/30th.daaam.proceedings.074.
6. M. Lalegani Dezaki and M. K. A. Mohd Ariffin, "The Effects of Combined Infill Patterns-on Mechanical Properties in FDM Process," *Polymers*, vol. 12, no. 12, p. 2792, Nov. 2020, doi: 10.3390/polym12122792.
7. A. R. Kafshgar, S. Rostami, M. Aliha, and F. Berto, "Optimization of Properties for 3D Printed PLA Material Using Taguchi, ANOVA and Multi-Objective Methodologies," *Procedia Struct. Integr.*, vol. 34, pp. 71-77, 2021, doi: 10.1016/j.prostr.2021.12.011.
8. J.-H. Yang, Z. Zhao, and S.-H. Park, "Evaluation of directional mechanical properties of 3D printed polymer parts," in 2015 15th International Conference on Control, Automation and Systems (ICCAS), Busan, Korea (South), Oct. 2015, pp. 1952-1954. doi: 10.1109/ICCAS.2015.7364685.
9. M. Hikmat, S. Rostam, and Y. M. Ahmed, "Investigation of tensile property-based Taguchi method of PLA parts fabricated by FDM 3D printing technology," *Results Eng.*, vol. 11, p. 100264, Sep. 2021, doi: 10.1016/j.rineng.2021.100264.
10. S. Raja et al., "Optimization of 3D Printing Process Parameters of Polylactic Acid Filament Based on the Mechanical Test," *Int. J. Chem. Eng.*, vol. 2022, pp. 1-7, Aug. 2022, doi: 10.1155/2022/5830869.