

**||Jai Sri Gurudev||**

**SRI ADICHUNCHANAGIRI SHIKSHANA TRUST ®**

**S.J.C.INSTITUTE OF TECHNOLOGY**

**CHICKBALLAPUR-562101**



**DEPARTMENT OF MECHANICAL ENGINEERING**

**DESIGN LAB**

**[BMEL606]**

CONTENTS		
SL.NO	EXPERIMENT	PAGE NO
1	CRITICAL OR WHIRLING OR WHIPPING SPEED OF SHAFT	7-9
2	PORTER GOVERNOR	10-12
3	HARTNELL GOVERNOR	13-15
4	TORSION VIBRATION (DAMPED)	16-18
5	TORSIONAL VIBRATION (UNDAMPED)	19-21
6	STATIC AND DYNAMIC BALANCING OF ROTATING MASSES	22-26
7	FREE UNDAMPED LONGITUDINAL VIBRATION OF SPRING MASS SYSTEM	27-28
8	STRESS –CONCENTRATION FACTOR USING PHOTO-ELASTICITY	29-32
9	FOUR POINT BENDING	33-34
10	CALIBRATION OF PHOTO- ELASTIC MATERIAL USING A CIRCULAR DISC UNDER COMPRESSION (DIAMETRICAL –COMPRESSION)	35-36
11	GYROSCOPE	37-38
12	SLIDER BEARING	39-42
13	JOURNAL BEARING	43-47
14	DETERMINATION OF PRINCIPAL STRESSES AND STRAINS IN A MEMBER SUBJECTED TO COMBINED LOADING USING STRAIN ROSETTES	48-52
15	VIVA QUESTIONS	53-54

**DESIGN LABORATORY****Subject Code: BMEL606****Hours/ Week: 03****Credits: 01****IA Marks : 50****Exam Marks : 50****Exam Hours : 03****EXPERIMENTS**

1. Determination of natural frequency, logarithmic decrement, damping ratio and damping coefficient in a single degree of freedom vibrating systems (longitudinal and Torsional).
2. Determination of critical speed of a rotating shaft.
3. Balancing of rotating masses.
4. Determination of Fringe constant of Photo elastic material using.
  - a) Circular disc subjected to diametral compression.
  - b) Pure bending specimen (four point bending)
5. Determination of stress concentration using Photo elasticity for simple components like plate with a hole under tension or bending, circular disk with circular hole under compression, 2D Crane hook.
6. Determination of equilibrium speed, sensitiveness, power and effort of Porter/Prowel /Hartnel Governor. (at least one).
7. Determination of Pressure distribution in Journal bearing.
8. Determination of Principal Stresses and strains in a member subjected to combined loading using Strain rosettes.
9. Determination of stresses in Curved beam using strain gauge

**DEMONSTRATIONS**

1. Study the principle of working of a Gyroscope and demonstrate the Effect of gyroscopic Couple on plane disc.
2. Demonstration and study of operation of different Mechanisms and their Inversions: Slider crank chain, Double slider crank chain and its inversions, Quick return motion mechanisms
3. Peaucellier's mechanism. Geneva wheel mechanism, Ratchet and Pawl mechanism, toggle mechanism, pantograph, Ackerman steering gear mechanism

- 
4. Demonstration of stress concentration using Photoelasticity for simple components like plate with a hole under tension or bending, circular disk with circular hole under compression

**Scheme of continuous Internal Examination:**

Experiments - 30Marks

Lab Internal - 20 Marks

-----  
**Total: -50 Marks**

**COURSE OBJECTIVES:** Students will be able to

1. Understand the basic knowledge of statics and dynamics.
2. Apply the knowledge of principles of mechanics to run the mechanical systems smoothly.
3. Determine the stresses induced and vibration characteristics of various mechanical components subjected to various loads by using measuring instruments.

**COURSE OUTCOMES:** At the end of the course the Student shall be able to

1. **Classify** the different types of equipments used for determine the stresses and strains in machine elements..
2. **Demonstrate** the experiments related to vibration, stability and stress analysis of machineries.
3. **Analyze** the forces, couples and stresses acting on machine components
4. **Evaluate** the Principal stresses and strains on the machine components subjected different types of loading
5. **Appraise** the importance of ethical issues and team working abilities pertaining to the design laboratory.

**REFERENCE BOOKS:**

- [1] “Shigley’s Mechanical Engineering Design”, Richards G. Budynas and J. Keith Nisbett, McGraw-Hill Education, 10th Edition, 2015.
- [2] “Design of Machine Elements”, V.B. Bhandari, TMH publishing company Ltd. New Delhi, 2<sup>nd</sup> Edition 2007.
- [3] “Theory of Machines”, Sadhu Singh, Pearson Education, 2nd Edition, 2007.
- [4] “Mechanical Vibrations”, G.K. Grover, Nem Chand and Bros, 6th Edition, 1996.

**Mapping of Course Outcomes with Program Outcomes**

<b>Course name and code: Design Lab[10MEL77]</b>												
	<b>Program Outcomes</b>											
<b>Course Outcomes(co)</b>	<b>PO1</b>	<b>PO2</b>	<b>PO3</b>	<b>PO4</b>	<b>PO5</b>	<b>PO6</b>	<b>PO7</b>	<b>PO8</b>	<b>PO9</b>	<b>PO10</b>	<b>PO11</b>	<b>PO12</b>
<b>Students will be able to</b>												
1. <b>Classify</b> the different types of equipments used to determine the stresses and strains in machine elements.	3	2	-	-	-	-	-	-	-	-	-	-
2. <b>Demonstrate</b> the experiments related to vibration, stability and stress analysis of machineries.	2	2	2	3	-	-	-	-	-	-	-	2
3. <b>Analyze</b> the forces, couples and stresses acting on machine components	2	2	3	3	-	-	-	-	-	-	-	2
4. <b>Evaluate</b> the Principal stresses and strains on the machine components subjected different types of loading	2	2	3	3	-	-	-	-	-	-	-	-
5. <b>Appraise</b> the importance of ethical issues and team working abilities pertaining to the design laboratory	-	-	-	-	-	-	3	3	2	-	-	-
<b>Average Attainment</b>	<b>2.25</b>	<b>2</b>	<b>2.66</b>	<b>3</b>	<b>-</b>	<b>-</b>	<b>3</b>	<b>3</b>	<b>2</b>	<b>-</b>	<b>-</b>	<b>2</b>

**1. Slight(Low)****2.Moderate(Medium)****3.Substantial (High)**

---

# **EXPERIMENT NO: 1**

## **CRITICAL OR WHIRLING OR WHIPPING SPEED OF SHAFT**

**AIM:** To determine the critical speed of a shaft or whirling speed of a shaft.

**APPARATUS:** Stop watch, Tachometer and Weights (optional)

### **THEORY:**

The speed at which the rotating shaft varies violently in transverse direction is called the “critical or whirling speed “or

When the speed of shaft is equal to natural frequency of vibration such a frequency is called as critical or whirling or whipping speed.

If the body or a disc mounted upon the shaft rotates about it, then C.G. of the disc must be at the shaft axis, if perfect running balance is to be obtained. But practically because of difficulty of perfect machining of disc (rotor) C.G does not coincide with shaft axis. Hence, when such shaft rotates, it deflects towards heavier side of the disc due to unbalanced centrifugal force. As the speed increases the shaft vibrates violently upto resonance speed, and after resonance speed the shaft again runs smoothly.

### **CRITICAL SPEED DEPENDS UPON THE FOLLOWING FACTOR:**

- 1.Length of the shaft
- 2.Diameter of the shaft
- 3.Bearing supports conditions i.e. fixed or free.
- 4.The magnitude of the load.
- 5.The location of the load carried by the shaft



Fig: Whirling speed of a shaft experimental set up

### **PROCEDURE:**

- 1) Fix the required shaft at the driving end.
- 2) Fix the Bearing block at tail end (either for fixed end condition or free end condition) And tighten the shaft
- 3) Start the motor and slowly increase the speed at certain speed discs will be vibrating violently and note down the speed of shaft.
- 4) Increase the speed now shaft is operating above critical speed without vibration.
- 5) Repeat the procedure by changing shaft.

### **SPECIFICATION:**

1. Shaft diameter ,  $d = \dots\dots\dots\text{m}$
2. Cross sectional area of the shaft,  $A = \dots\dots\dots\text{m}^2$
3. Bearing block
  - a. Driving end: - Fixed end shaft supported with two Bearing
  - b. Tail end: - Fixed end support with self-aligning ball Bearing
  - c. Young's modulus of the shaft,  $E = \dots\dots\dots\text{N/m}^2$
  - d. Length of the shaft,  $L = \dots\dots\dots\text{m}$
3. Moment of inertia of the shaft,  $I = \dots\dots\dots\text{m}^4$
4. Uniformly Distributed Load
  - = 0.064 kg/m for 3.17 mm diameter shaft.
  - = 0.138 kg/m for 4.75 mm diameter shaft
  - = 0.248 kg/m for 6.35 diameter shaft
5. Mass of the shaft,  $m = \dots\dots\dots\text{Kg}$
6. Density of the shaft material ( $\rho$ )  $\dots\dots\dots\text{Kg/m}^3$

**FORMULAE:****a. For bending mode:**

$$\text{Angular speed, } \omega = (22a) / L^2 \quad \text{rad/ s}$$

$$\text{Where, } a = \sqrt{(EI/A\rho)},$$

$$\text{Critical speed, } N = (\omega \times 60) / 2\pi \quad \text{rpm}$$

**b. For twisting mode:**

$$\text{Angular speed, } \omega = (61.7 a) / L^2 \quad \text{rad/s}$$

$$\text{Critical speed, } N = (\omega \times 60) / 2\pi \quad \text{rpm}$$

**TABULAR COLUMN:**

Sl.No	Diameter of shaft (d) 'm'	Length of shaft (L) 'm'	Critical Speed (N) in rpm			
			Bending mode		Twisting mode	
			Theoretical	Experimental	Theoretical	Experimental
1						
2						
3						
4						

## **EXPERIMENT: 2**

### **PORTER GOVERNOR**

**AIM:** To determine the theoretical lift, friction and controlling of the governor.

**APPARATUS:** universal governor experimental set-up, Tachometer, Set of masses.

#### **PROCEDURE:**

1. Place the porter governor assembly over the spindle of the universal governor setup
2. Place the required load on the spindle
3. Tighten the bolts and nuts
4. Start the motor adjust the speed to the required value
5. Note down the sleeve rise (lift) and also the speed
6. Repeat the experimental procedure for different loads and different speeds

#### **SPECIFICATION: -**

- ❖ Length of each Link,  $L = \dots\dots\dots$  m
- ❖ Distance of top link from bottom link  $2k = 2k_0 = \dots\dots\dots$  m
- ❖ Height of balls where central lines intersect with the axis of rotation,  
 $h = m = h_0 = \dots\dots\dots$  m
- ❖ Initial radius of rotation  $r_0 = r = \dots\dots\dots$  m
- ❖ Mass of sleeve assembly  $M = \dots\dots\dots$  kg.
- ❖ Weight of sleeve assembly  $W = \dots\dots\dots$  N
- ❖ Mass of one side balls  $m_b = \dots\dots\dots$  kg.
- ❖ Weight of one side balls  $w_b = \dots\dots\dots$  N



**TABULAR COLUMN:**

Sl.No	Mass of Sleeve 'kg'	Masses added to Sleeve 'kg'	Total mass (M) 'kg'	Governor speed (N) rpm	Radius of rotation in (r <sub>1</sub> ) m	Sleeve lift 'x <sub>1</sub> ' 'm'		Controlling force (F <sub>c</sub> ) 'N'	Frictional force (F) 'N'
						Exp	Theo		
1									
2									
3									

**FORMULAE :**

- ❖ Height of the governor =  $h_1 = [(m_b g + Mg) / m_b] * (1/N^2) * (60/2\pi)^2$
- ❖  $L^2 = \{ [h_1^2 / (0.05 + s_1)^2] + 1 \} S_1^2$  by trial and error method find  $S_1$
- ❖  $k_1 = \sqrt{L^2 - s_1^2}$  ,
- ❖ Theoretical lift,  $x_1 = 2(k_0 - k_1)$
- ❖ Controlling force:  $F_c = m_b \omega_1^2 r_1$ ,

Where  $r_1 = \text{Radius of rotation} = 0.05 + s_1$

- ❖ Frictional force =  $h_1 = \{ w_b + (w \pm F) / m_b \} 1 / N^2 * (60/2\pi)^2$

## **EXPERIMENT: 3**

### **HARTNELL GOVERNOR**

**AIM:** To determine the theoretical lift, friction and controlling of the governor.

**APPARATUS:** universal governor experimental set-up, Tachometer, Set of masses and springs of different stiffness.

#### **PROCEDURE:**

1. Mount the given Hartnell governor assembly over the spindle.
2. Tighten the necessary nuts and Bolts.
3. Start the motor and adjust the speed.
4. The flyweight's fly outwards due to centrifugal force, the sleeve will raise.
5. Measure the sleeve and sleeve rise.
6. Repeat the experiments at different speeds spring forces over the sleeve by changing the initial compressions and springs of different stiffness of the governor.
7. Calculate the lift, friction and controlling force of the governor.

#### **SPECIFICATIONS: -**

- Motor speed,  $N =$                   rpm.
- Stiffness of spring,  $K =$                   N/m
- Length of the ball arm = 'a' =                  m
- Length of the sleeve arm = 'b' =                  m
- Mass of one side balls = 'm<sub>b</sub>' =                  kg
- Initial radius of rotation of balls = 'r<sub>0</sub>' =                  m
- Mass of sleeve only =                  kg

**FORMULAE:**

1. To find lift (x) :-

$$m_b \omega^2 r = b/a \{ w + k (x+d) \}$$

$$\text{where } r = (a/b * x) + r_0 \quad \text{in m}$$

2. To find friction :-

$$m_b \omega^2 r = (b/a) * \{ [w + k (x+d) ] / 2 \} \pm F$$

3. To find controlling force

$$F_c = m_b \omega^2 r \quad \text{in N}$$

**TABULAR COLUMN:**

Sl. No	Stiffness of the spring (K) N/m	Mass of Sleeve 'kg'	Weight of the sleeve (W) N	Initial length of the spring 'm'	Final length of the spring 'm'	Diff between the spring length (d) 'm'	Gov speed (N) 'Rpm'	Lift (x) in m		Controlling force (F <sub>c</sub> ) 'N'	Frictional force (F) 'N'
								Exp	Theo		
1											
2											
3											
4											

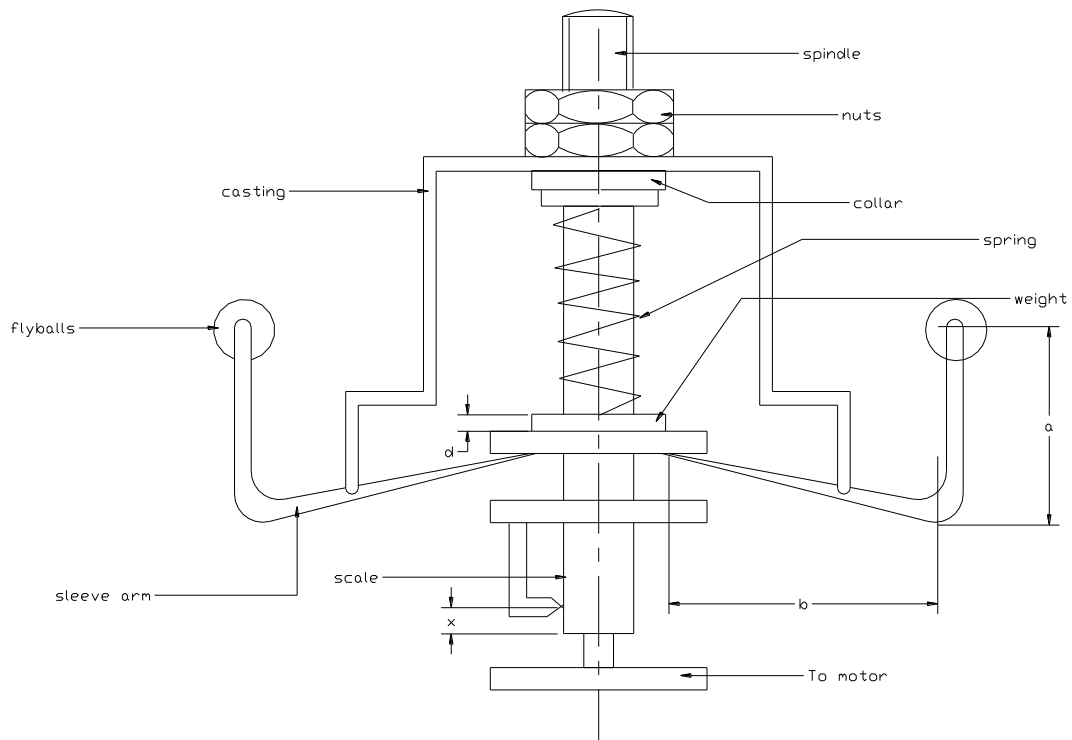
**EXPERIMENTAL SET UP :****Fig: Hartnell governor****GRAPHS:**

1. Controlling force v/s speed
2. Controlling force v/s radius of rotation.

---

## EXPERIMENT 4

### TORSIONAL VIBRATION (DAMPED)

**Aim:** To study the damped torsion vibration of a single rotor system and to determine the damping factor logarithmic decrement.

**Apparatus:** - Rotor, Descender (penholder)

**Procedure:** -

- 1) Fix the shaft at the bracket at the top
- 2) Attach the rotor, and descender to the shaft
- 3) Put the damping liquid ( oil or water ) into the damping reservoir and set the pen holder at suitable position
- 4) Oscillate the rotor carefully, so that lateral oscillation does not appear.
- 5) Lift the descender and gently press the pen over the paper and graph of oscillation should be recorded over the paper.
- 6) Measure height of amplitude from the graph
- 7) Repeat above procedure by changing depth of immersion in liquid medium.
- 8) Plot the graph of logarithmic decrement v/s depth of immersion.

**FORMULAE:**

**1) Logarithmic decrement ( $\delta$ ):**

$$\delta = (1/n) \times \ln (x_0/x_n)$$

Where  $x_0$  = Initial amplitude  
 $x_n$  = amplitude of the  $n^{\text{th}}$  cycle.  
 $N$  = number of cycles.

**2) Damping factor ( $\xi$ ):**

$$\delta = (2 * 3.14 * \xi) / (\sqrt{1-\xi^2})$$

**Tabular column :**

Sl no.	Depth of Immersion (d) in mm	Logarithmic Decrement ( $\delta$ )	Damping factor ( $\xi$ )
1			
2			
3			
4			
5			

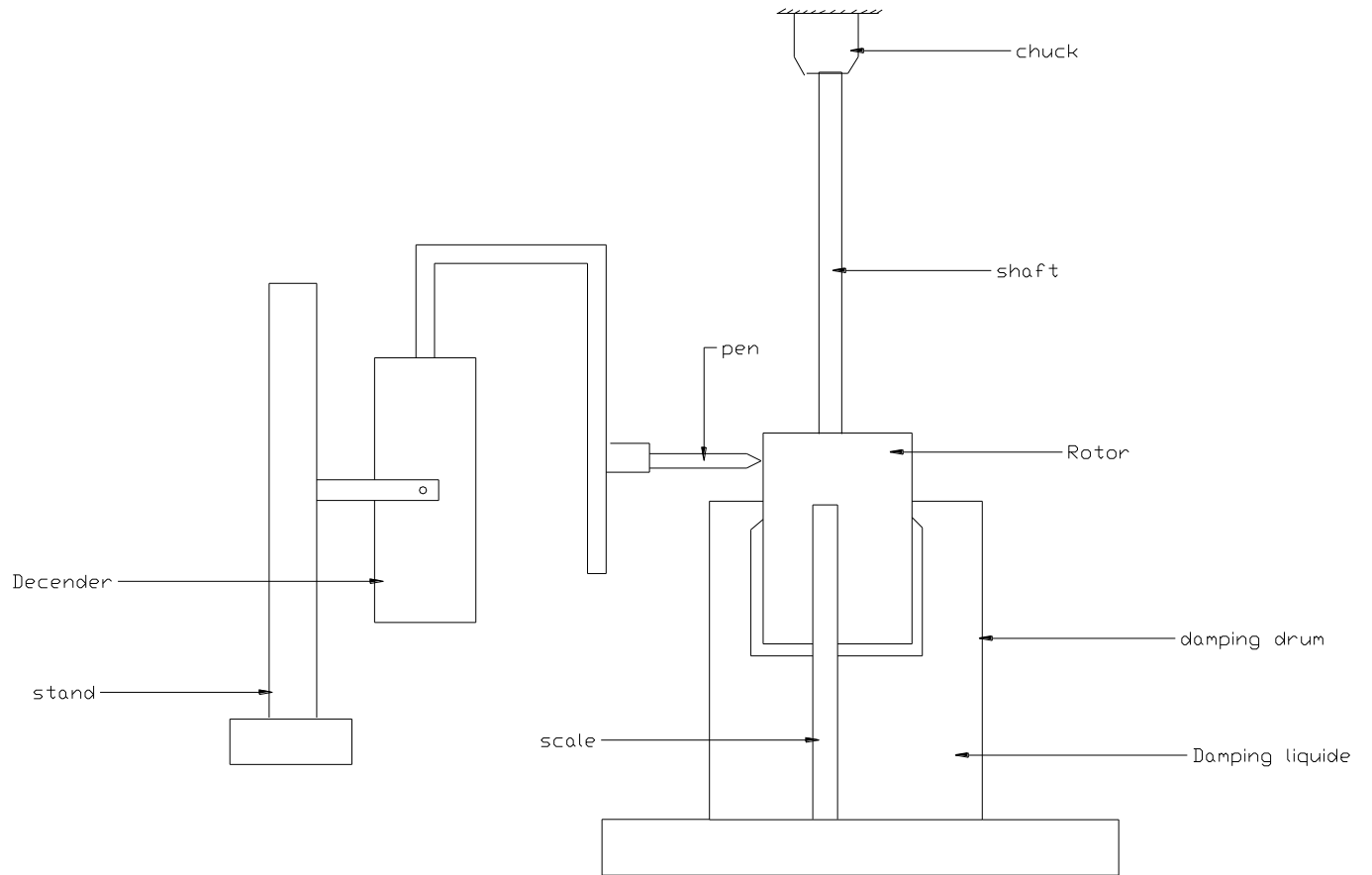

Fig. Damped Torsion vibration apparatus

---

## EXPERIMENT 5

### TORSIONAL VIBRATION (UNDAMPED)

**Aim:** - To determine frequency of undamped torsional vibration of a single rotor system.

**Apparatus:** - Stop watch, Single rotor systems.

**Procedure:** -

1. Fix the rotor at the threaded spindle, fitted in the bearings.
2. Fix the gripping chuck over the spindle
3. Fix the stationary speed bracket at suitable length
4. Thread the shaft through the spindle and tighten the chuck.
5. Oscillate the rotor by hand and measure the time taken for 10 oscillations.
6. Repeat the experiment for different length of the shaft.

**Formulae:**

1) Experimental frequency  $f_n = 1/t_p$

Where  $t_p$  = Time period.

2) Theoretical frequency  $f_t = (1 / (2 * 3.14)) * (\sqrt{(GJ / IL)})$

Where  $G$  = rigidity modulus of given material

$J$  = polar moment of inertia

$I$  = mass moment of inertia =  $(1/2) * mk^2$

$m$  = mass of rotor

$k$  = radius of rotor.

**Tabular column:**

SL.no	Length of shaft (L) 'mm'	Time taken for		Frequency in Hz	
		10 oscillation in Sec	1 oscillation in Sec	Exp	Theo
1					
2					
3					
4					
5					



Fig. Damped and Undamped single Rotor Torsional set up

---

## EXPERIMENT: 6

# STATIC AND DYNAMIC BALANCING OF ROTATING MASSES

**Aim:** To find static and dynamic balancing rotating masses.

**Apparatus:** It consists of a frame, which is hanging by chains from the main frame. A shaft rotates within bearings in the frame. Four eccentric weights are supplied which can be easily fitted over the shaft. For static balancing one weight is attached and balanced with another weight. For dynamic balancing three or four weights are mounted over the shaft at calculated angle and the shaft is rotated. If the system is unbalanced, vibrations indicate it.

### **Theory**

Balancing of masses is important part of a machine design, when the mass is stationary it can be easily balanced by putting suitable counter weight on the opposite side of mass. When the mass is revolving and if it is left unbalanced, then a centrifugal force is developed which changes its direction during rotation. This causes premature failure of bearings and shafts are unbalanced, hence balancing is essential in machine design.



Fig. Static and Dynamic balancing experimental set up

## **Procedure:**

### **1) Static balancing:**

- 1) Remove the leather rope over the pulley.
- 2) Fix the points at  $0^0$  positions.
- 3) Attach the weight pans on both sides.
- 4) Remove locking screw and go on putting steel balls in the pan till, the points is turned through  $90^0$ .now the weights is balanced by steel balls count number

of balls. This is relative balancing weight for the eccentric weight. Find out relative weight for all eccentric weight and note down.

## 2) Dynamic balancing: -

From the relative weight (number of balls) assume position of two of the weights over shaft, draw the force polygon and find out position of other weights.

- 1) Mount the weights at proper position over the shaft.
- 2) Put the leather belt over the pulley and start the motor.
- 3) If the system is balanced, the shaft will rotate free from vibrations.

## CALCULATIONS:

### 1) Static balancing: -

Let the given weights be  $m_1r_1$  and  $m_2r_2$  with an angle between them be  $m_3r_3$  and  $m_4r_4$  are the balancing weights whose angular position are to be determined. Draw positions of  $m_1r_1$  and  $m_2r_2$  in the position diagram. to draw force polygon draw AB parallel to  $m_1r_1$  to some scale, from A, draw an arc whose radius is proportional to  $m_4r_4$  and from C draw an arc with radius proportional to  $m_3r_3$  the intersection of arc gives point D. Join AD and CD draw parallel lines to CD and AD in position diagram, this will give angular position of  $m_3r_3$  and  $m_4r_4$  respectively.

### 2) Dynamic balancing: -

Follow the procedure for static balancing of the system and find out angular position of balance weights. To find the linear position couple polygon is required, assume linear position of  $m_1r_1$  taking moments about rotating plane of  $m_3r_3$  couples are 1)  $m_1r_1 \times a_1$  2)  $m_2r_2 \times a_2$  3)  $m_4r_4 \times a_4$

Draw 'ab' parallel to  $m_1r_1$  to the scale of  $m_1r_1$  couple. From 'b' draw parallel to  $m_2r_2$  from 'a' draw parallel line to  $m_4r_4$ . The intersection gives point 'c'. "bc" is proportional to  $m_2r_2 \times a_2$  and "ac" is proportional to  $m_4r_4 \times a_4$ . As  $m_2r_2$  and  $m_4r_4$  are known values of  $a_2$  and  $a_4$  can be determined.

**Calculation:**

$$m_1 = \quad \text{gr}$$

$$m_2 = \quad \text{gr}$$

$$m_3 = \quad \text{gr}$$

$$m_4 = \quad \text{gr}$$

$$r_1 = \quad \text{cm}$$

$$r_2 = \quad \text{cm}$$

$$r_3 = \quad \text{cm}$$

$$r_4 = \quad \text{cm}$$

**To find  $\theta_3$  and  $\theta_4$ : -**

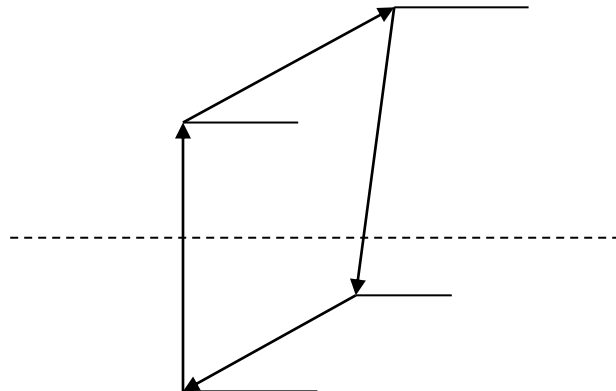
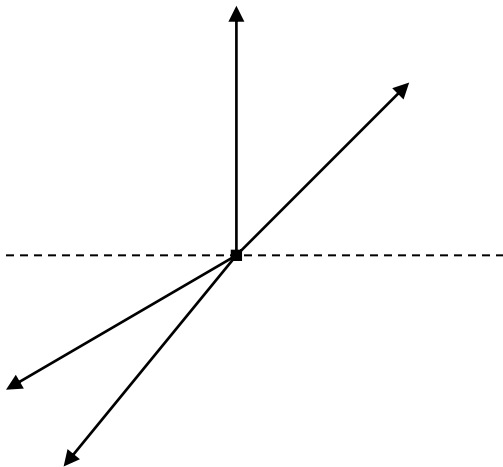

**TO FIND LINEAR POSITIONS :-**

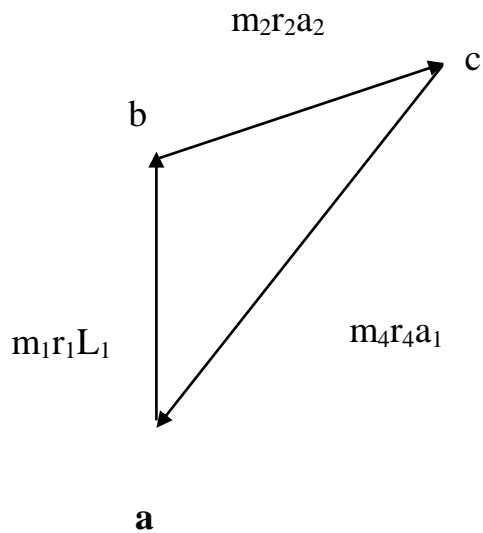
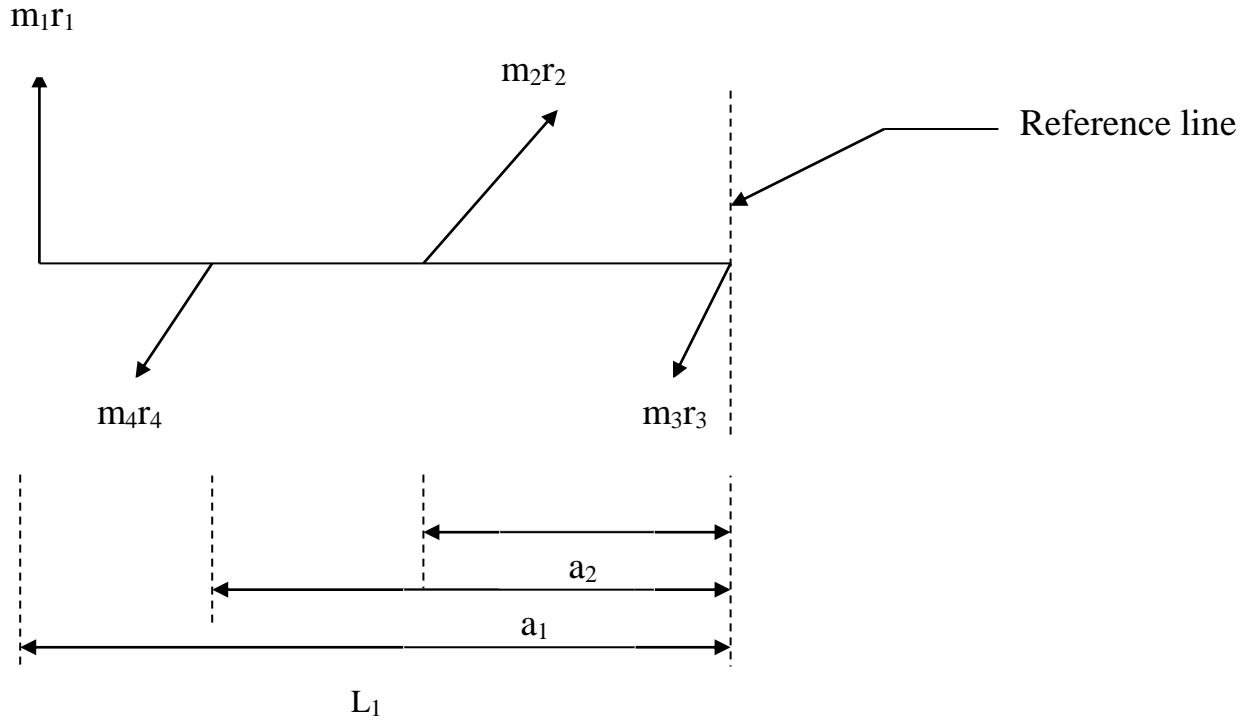

**From graph**

$$m_2r_2a_2 = 'x' \text{ mm}$$

$$\therefore a_2 = x / m_2r_2$$

$$m_4r_4a_1 = 'y' \text{ mm}$$

$$\therefore a_1 = 'y' / m_4r_4$$

---

## EXPERIMENT: 7

### FREE UNDAMPED LONGITUDINAL VIBRATION OF SPRING MASS SYSTEM

**AIM:** To study the undamped free vibration of the spring mass system

**APPARATUS:** Stopwatch, weights, and vernier scale.

**PROCEDURE:**

1. Fix the spring in the strut; attach the weight holder to the spring.
2. Fix the scale for measurement of elongation of spring at the suitable position. Note initial reading, attach different weights to the spring and note down the corresponding deflections.
3. Find out the stiffness of the spring 'K'
4. Repeat the experiments with different springs
5. Now, with weights attached to the spring set the spring vibrating and note down the time period.
6. Repeat the experiment with different springs and different weights.

**EXPERIMENTAL SET UP:**

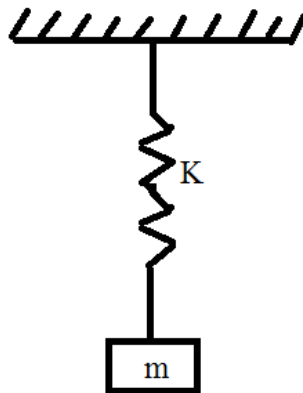

**FORMULAE:**

$\delta$  = Deflection = final length – initial length.

$K$  = stiffness of the spring =  $mg / \delta$  (or Take from the graph Force (mg) Vs deflection)

$$f_n (\text{Exp}) = 1/t_p$$

$$f_n (\text{Theo.}) = (1/2\Pi) * \sqrt{(K/m)} = (1/2\Pi) * \sqrt{(g/\delta)}$$

Where  $g$  = Acceleration due to gravity in  $m/s^2$

$m$  = attached mass in kg

**TABULAR COLUMN:**

Sl.no	Attached mass (m) in 'kgs'	Deflection ( $\delta$ ) in 'm'	Stiffness (K) in 'N/m'	Time (T) for in sec		Frequency ( $f_n$ ) in 'Hz'	
				10 osc	1 osc	Exp.	theo.
1							
2							
3							
4							
5							

---

## EXPERIMENT NO.8

# STRESS –CONCENTRATION FACTOR USING PHOTO- ELASTICITY

**AIM:** To determine stress concentration factor for a circular disc with a circular hole under diametrical compression.

**APPARATUS:** Circular Polariscopes, photo elastic model in the form of circular disc with a circular hole, vernier caliper.

### **THEORY:**

In the development of the basic stress equations for tension, compression, bending and torsion, it was assumed that no irregularities occurred in the member under consideration. But it is quite difficult to design a machine without permitting some changes in the cross-sections of the members.

Ex: rotating shafts must have shoulders designed on them so that the bearing can be properly sealed and so that they will take thrust loads. Other parts require holes, oil grooves and notches of various kinds.

Any discontinuity in a machine part alters the stress distribution in the neighborhood of the discontinuity so that the elementary stress equations no longer describe the state of stress in the part, such discontinuities are called stress raisers and the regions in which they occur are called areas of stress concentration.

#### **Theoretical or geometric, stress-concentration factor $k_t$**

It is the ratio of actual maximum stress at the discontinuity to the normal stress.

$$k_t = \sigma_{\max} / \sigma_o \qquad k_{ts} = \tau_{\max} / \tau_o$$

Where  $k_t$  used for normal stresses,

$k_{ts}$  used for shear stresses.

The subscript t in  $k_t$  means that this stress-concentration factor depends for its value only on the geometry of the part. That is, the particular material used has no effect on the value of  $k_t$ , this is why it is called theoretical stress-concentration factor.

**PROCEDURE:**

1. The circular specimen is mounted between the lever arm which is extended from the fulcrum to the load acting on other side.the light emitted from sodium vapor lamp of circular polariscope is analyzed using both polarizes and analyzer.
2. The load is applied in the weight hanger and the fringe pattern is observed .the total number of integral formed plus the fractional fringes are counted and the fringe order is noted.
3. The load acting on the specimen is calculated. Repeat the procedure for various loads. At each load calculate the nominal and maximum stress acting on the specimen.
4. A graph is plotted b/w  $\sigma_{\max}$  v/s  $\sigma_0$  and the slope of this is obtained in order to calculate average value of stress concentration factor

**SPECIMEN SPECIFICATIONS: -**

- ❖ Outer diameter of specimen D =                      mm
- ❖ Inner diameter of the specimen d =                      mm
- ❖ Thickness of the specimen h =                      mm
- ❖ Distance x =                      mm
- ❖ Distance y =                      mm

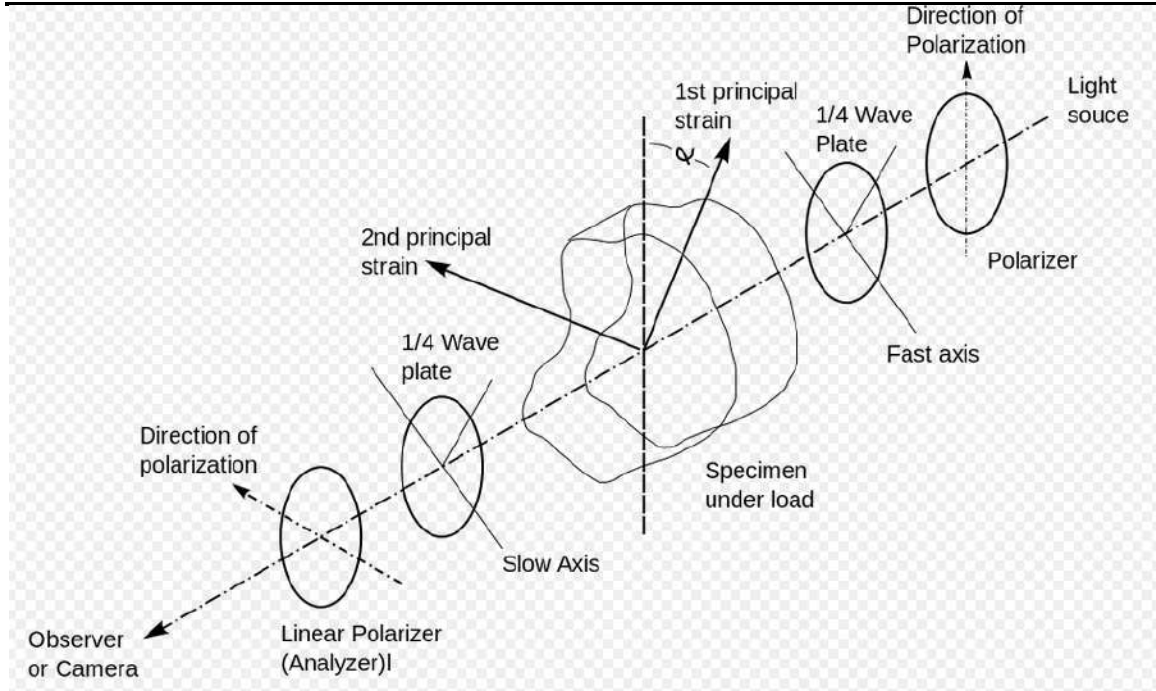

Fig: Circular polariscope experimental set up.

**Tabular column:**

Sl.no	Load on hanger		Load on disc 'P' N	Fringe order N	$\sigma_{act}$ in N/mm <sup>2</sup>	$\sigma_{max}$ in N/mm <sup>2</sup>	$K_{\sigma}$
	Kg	N					
1							
2							
3							
4							
5							
6							
7							

**FORMULAE:**

- ❖ Load on the disc
  - $P * x = w * y$
  - $P = (w * y) / x$  in N
- ❖  $\sigma_{nom} = p / (D-d) h$  in N/mm<sup>2</sup>
- ❖  $\sigma_{act} = N F_{\sigma} / h$  in N/mm<sup>2</sup>
  - Where N= fringe order
- ❖  $F_{\sigma}$  = Material fringe constant
- ❖  $K_{\sigma} = \sigma_{act} / \sigma_{nom}$

## EXPERIMENT NO.9

### FOUR POINT BENDING

**AIM:** - To calculate the bending stress of a beam using photo- elastic specimen.

**APPARATUS:** - circular polariscope, test specimen, weights and vernier caliper.

#### **PROCEDURE:** -

Place the specimen in the loading frame of the polariscope .the test specimen is supported as a beam, subjected to pure bending as a four pointing bending set-up, where load is applied in the weight hanger and the fringe pattern is observed. The total number of integral fringes formed plus the fractional fringes are counted. Repeat the procedure for various loads, at each load calculate the actual stress acting on the specimen and compare the actual stress with theoretical one.

#### **SPECIFICATION:**

##### **For rectangular specimen:**

- ❖ Height “H” =        mm
- ❖ Breath “B” =        mm
- ❖ Length “L” =        mm
- ❖ Where “a” is the distance from the loading point to the reaction point  
=            mm
- ❖ Length  
    “L<sub>1</sub>” =            mm  
    “L<sub>2</sub>” =            mm  
    “L<sub>3</sub>” =            mm
- ❖ Diameter “d” =    mm.

**FORMULAE:**

❖ Actual stress =  $\sigma_{act} = (N F_{\sigma}) / h$       N/mm<sup>2</sup>

Where N is fringe order

$F_{\sigma}$  is Material fringe constant.

❖ Theoretical stress  $\sigma_{theo} = (6 * P * a) / (b H^2)$  in N/mm<sup>2</sup>

Where P = Load on specimen =  $(2 W L_1) / (L_2 + L_3)$  in N

**TABULAR COLUMN:**

Sl no	Load in hanger (W)		Load on specimen (P) in N	Fringe order (N)	$\sigma_{act}$ N/mm <sup>2</sup>	$\sigma_{theo}$ N/mm <sup>2</sup>
	Kg	N				
1						
2						
3						
4						

## **EXPERIMENT NO.10**

### **CALIBRATION OF PHOTO- ELASTIC MATERIAL USING A CIRCULAR DISC UNDER COMPRESSION (DIAMETRICAL –COMPRESSION)**

**AIM:** To determine the material and model fringe constant, using photo elastic material under diametrical compression

**APPARATUS:** photo-elastic apparatus with polarizer analyzer and photo elastic specimen.

#### **PROCEDURE:**

The circular disc is mounted between the lever arms, which is extended from the fulcrum to the load acting on the other side. The light emitted from the sodium vapor lamp of the circular polariscope is analyzed using both polarizer and analyzer. This setup is set in dark field and then the load is applied in the weight hanger. This exerts a pressure on the disc at the vertical edge and the fringe pattern appears which can be seen through the analyzer.

The analyzer is rotated till the emerging fringe at the edge coincides with the clearly formed fringe at the center of the specimen. The angle of rotation and the fringe order is determined. Repeat the experiment for different loads on the pan and determine various parameters. The fractional fringes are compensated by Tardy's compensation method. The analyzer is turned in clockwise or counterclockwise to move the fringe from lower to higher order or vice versa, until the fringe coincides and separates and the angle turned is noted.

**Case1:** - Fringes move from higher order to lower order.

The total number of fringes = number of Integral fringes – angle turned /180°

**Case 2:** - when the fringes move from lower to higher order

The total number of fringes = number of Integral fringes + angle turned /  $180^{\circ}$

A graph is plotted between P v/s N and the slope of is obtained in order to calculate material and fringe constant.

### **SPECIFICATION:**

Diameter 'D' =           mm

Thickness 'h' =           mm

Length 'L<sub>1</sub>' =           mm

'L<sub>2</sub>' =           mm

### **TABULAR COLUMN:**

Sl.no	Weight applied		Load acting on specimen (P) in N	Fringe order (N)
	Kg	N		
1				
2				
3				
4				
5				

### **FORMULAE:**

a) Load acting on specimen

$$W_1 * (L_2 + L_1) = P * L_2$$

b) Material fringe constant:

$$F_{\sigma} = (P / N) * (8 / 3.14 * D) \quad \text{in N / mm -Fringe}$$

Where P=Load acting on specimen

N=Fringe order

D=Diameter of specimen

c) Model Fringe constant: -

$$f_{\sigma} = F_{\sigma} / h \quad \text{in mm}$$

---

**EXPERIMENT NO.11****GYROSCOPE**

**AIM:** To find the angular velocity of precision.

**APPARATUS:** Stop clock, gyroscope tachometer, Weights.

**PROCEDURE:**

1. Check the rotor for vertical position
2. Adjust the balance weights slightly if necessary
3. Keep the dimmer stat at required position
4. Start the motor by applying the voltage
5. Adjust the speed as required
6. Note down the rotor speed with help of tachometer
7. Speed is noted at steady state
8. Put the weights on the stud & at the same time start the stop clock & note down the time for  $45^0/90^0$
9. Repeat the experiment for different weights & speed

**SPECIFICATION:**

- ❖ Mass of Rotor  $M =$  Kg
- ❖ Diameter of rotor  $d =$  m
- ❖ Distance between weights stud & center of disc = m
- ❖ Mass moment of inertia of disc  $I = mr^2/2 =$  kg.m<sup>2</sup>

**FORMULAE:**

- 1) Angular velocity of disc  $\omega = 2\pi N/60$
- 2) Angular velocity of precision  $(\omega_p)_{exp} = \text{angle turned} / \text{time taken}$
- 3) Angular velocity of precision  $(\omega_p)_{theo} = M_t/I\omega$

**TABULAR COLUMN:**

Sl no	Rotor Speed 'N' rpm	Mass added in 'Kg'	Time taken (T) for angle turned		Velocity of precision	
			Angle 'θ'	Time 'sec'	(ω <sub>p</sub> ) <sub>exp</sub> rad/s	(ω <sub>p</sub> ) <sub>theo</sub> rad/s
1						
2						
3						

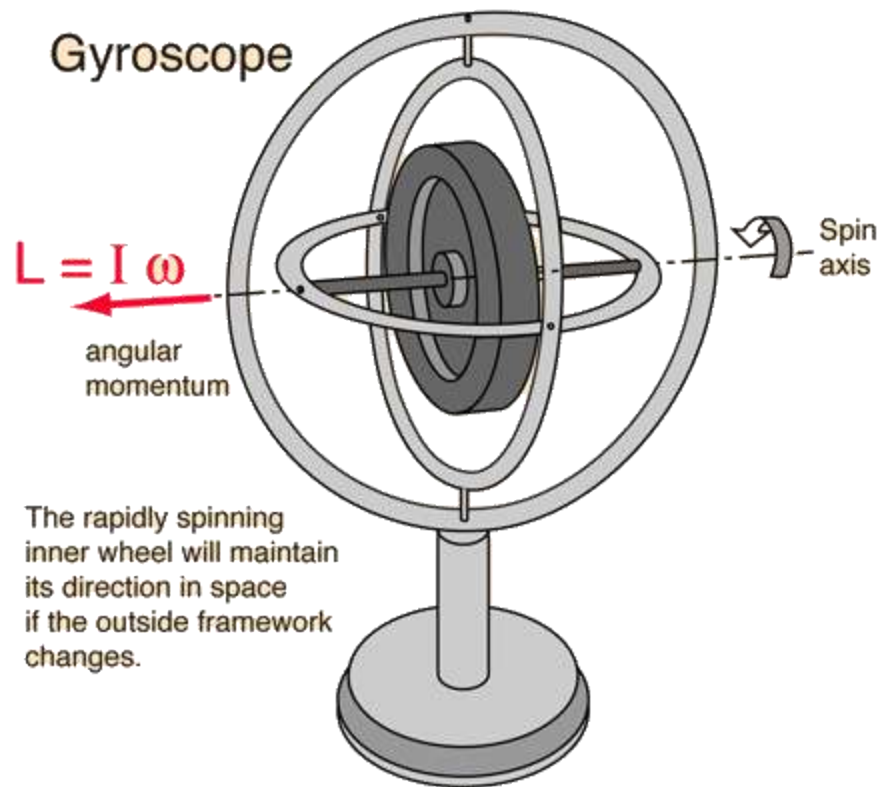

Fig: Gyroscope

---

## EXPERIMENT NO.12

### SLIDER BEARING

**AIM:** To find the pressure distribution over the bearing.

**APPARATUS:** slider bearings, apparatus, Manometer, Filler Gauge, Tachometer & thermometer.

**PROCEDURE:**

1. Motor is connected to the supply
2. The oil of required viscosity is filled in the tank to a particular level such that lower part of the belt is completely immersed in oil.
3. The tilting pad is adjusted with the help of chuck nut & filler gauge to get the required value of 'n' by adjusting  $h_0$  &  $h_1$
4. The motor is started & speed is gradually raised till we get required speed of shaft, which is connected to the motor by a V-belt drive
5. The readings for pressure head in all the tubes is measured only after the equilibrium condition has reached, at this time oil temperature should be noted down to get exact value of viscosity
6. Keeping  $h_0$  &  $h_1$  same pressure heads for different speeds are noted.

**SPECIFICATION & OBSERVATION:**

- Length of the driven pulley  $L = 137$  mm
- Width of the belt  $B = 120$  mm
- Diameter of roller  $D = 112$  mm
- Grade of oil used = SAE 40
- Oil film thickness at entry side  $h_1 = 3$ mm
- Oil film thickness at exit  $h_0 = 2$ mm
- Speed  $N = 280$  rpm
- Density of oil =  $853 \text{ kg/m}^3$
- Viscosity of oil at  $32^\circ\text{C} = 0.283 \text{ N-S/m}^2$



Fig: Slider bearing experimental set up.

### **FORMULAE:**

$$1) \text{ Pressure } p = 6\eta VL / h_0^2 \left\{ \frac{nX/L (1-X/L)}{(2+n)(1+nX/L)^2} \right\} \text{ N/m}^2$$

Where  $n = (h_0 / h_1) - 1$

$X$  = tapping distance in mm

$\eta$  = Viscosity of the given oil

$V = \pi DN / 60$   $N$  = speed of the driven pulley

2) Theoretical oil film thickness  $h_{\text{theo}} = p/\rho g$

Where  $\rho$  = density of the oil  
 $g$  = acceleration due to gravity

3) Load carrying Capacity  $W = 6\eta VBC_1/k^2$

Where  $C_1 = \ln(a-k/a) + (2k/2a-k)$   
 $k = (h_0 - h_1) / B$   
 $a = h_0 / B$

4) Frictional force =  $\eta VLC_2$

Where  $C_2 = (-4/k) \ln(a-k/a) - (6/2a-k)$

5) Co efficient of friction =  $F/ w$

## **TABULAR COLUMN:**

### **Longitudinal tapings**

Taping no	$h_{\text{practical}}$ in 'm'	$h_{\text{theo}}$ in 'm'	Pressure in 'N/m <sup>2</sup>	Taping distance X in 'm'
1				
2				
3				
4				
5				
6				
7				
8				
9				

**Transverse tapings**

Taping no	$h_{\text{practical}}$ in 'm'	$h_{\text{theo}}$ in 'm'	Pressure in 'N/m <sup>2</sup> '
A			
B			
C			
D			
E			
F			
G			
H			

---

## EXPERIMENT NO.13

### JOURNAL BEARING

**AIM:** To determine the pressure distribution in the oil film of the bearing for various speeds & plot the Cartesian & polar pressure curve for various speeds. Also determine the constants 'n' & 'k' & plot the sommerfield pressure curve for each Speed.

**APPARATUS:** Journal bearing apparatus, dimmer stat, Tachometer, Dc motor, Manometer counter balance & weights.

#### **PROCEDURE:**

1. fill the oil tank using required SAE grade oil under test & position the tank at the desired level
2. Drain out the air from all the tubes of the manometers & check level balance with the supply level.
3. Check for any leakage of the oil.
4. Some leakage of the oil is necessary for cooling purpose
5. Check the direction of rotation & increase the speed of motor slowly.
6. Set the speed & let the journal run for about 30 minutes. until the oil in the bearing is warmed up
7. Check the steady oil level at various tappings.
8. Add required load & keep the balancing load in horizontal position & observe the steady level.
9. When the manometer level settles down to steady level take the pressure readings of 16 manometer tubes
10. Repeat the experimental for various speeds & constant loads or constant speed & varying load.

**SPECIFICATION & OBSERVATION:**

- ❖ Diameter of journal  $d = \dots\dots\text{mm}$
- ❖ Length of journal  $L = \dots\dots\text{mm}$
- ❖ Diameter of bearing  $D = \dots\dots\text{mm}$
- ❖ Speed of the motor =  $\dots\dots\text{rpm}$
- ❖ Hanger Weight =  $\dots\dots\text{N}$
- ❖ Total weight =  $\dots\dots\text{N}$
- ❖ Initial Pressure  $P_0 \dots\dots\text{N/m}^2$



Fig: Journal Bearing experimental set up

**TABULAR COLUMN:**

Manometer	Pressure head (P) in m	Pressure Diff (P- P <sub>0</sub> ) in m
1		
2		
3		
4		
5		
6		
7		
8		
9		
10		
A		
B		
12		
C		
D		

**FORMULAE :**

Pressure distribution in Journal

$$(P - P_0)_{\max} = -K \sin\theta(2 + \varepsilon \cos \theta) / (1 + \varepsilon \cos \theta)^2$$

i. Find K = .....

Where  $\theta_{\max} = \dots\dots$  Get the value from the Graph

ii.  $\cos\theta_{\max} = -3 \varepsilon / (2 + \varepsilon^2)$

iii. Get  $\varepsilon$  .... From the above Equation

Load Carried by oil in the projected area

iv.  $W = hpdL$

Where Avg Film Thickness  $h = \text{sum of } (P - P_0) / \text{number of positive Value}$

$$\text{Theoretical Load } w = \left\{ \frac{12 \eta r^3 \omega \pi}{\delta} \right\} X \left( \frac{\varepsilon}{2 + \varepsilon^2} \right) X \left\{ \frac{1}{\sqrt{1 - \varepsilon^2}} \right\}$$

Where  $\delta$  = Radial clearance =  $D - d / 2$

$$\text{Frictional Couple } M = \left\{ \frac{4 \eta r^3 \omega \pi}{\delta} \right\} X \left( \frac{1 + 2\varepsilon^2}{2 + \varepsilon^2} \right) X \left\{ \frac{1}{\sqrt{1 - \varepsilon^2}} \right\}$$

$$\text{Frictional Force } F = \frac{2 \eta N L d \pi^2}{\psi}$$

b. coefficient of friction  $\mu = F / w$

---

## **EXPERIMENT NO.14**

# **DETERMINATION OF PRINCIPAL STRESSES AND STRAINS IN A MEMBER SUBJECTED TO COMBINED LOADING USING STRAIN ROSETTES**

**AIM:** Determination of Principal Stresses, strains, Maximum shear stress and strain in a member subjected to combined loading using Strain rosettes.

**APPARATUS:** Strain gauge rosette, Digital strain indicator, Hollow shaft, load hanger...

**THEORY:** The mathematical analysis of stresses in complex components may not in some cases, be practical or either not available or cumbersome and uneconomical. It would be essential to have the backing of reliable experimental stress analysis or strain measurement techniques have served an increasingly important role in aiding designers to produce not only efficient but economic designs. The accurate measurement of stresses, strains and loads in components under working conditions is an essential requirement of successful engineering design. In particular location of peak stress values and stress concentration and subsequently their reduction or removal by suitable design, has application in every field of engineering.

The main techniques of experimental stress analysis which are in use today are

1. Brittle Lacquers
2. Strain gauges
3. Photoelasticity
4. Photo elastic coatings
5. Moire Techniques
6. Holography...

**STRAIN GAUGES:** A strain gauge is a strain transducer. It is a device for measuring dimensional change on the surface of a structural member under test.

**ROSETTS:** Multiple grid or rosettes are a group of gauges bonded in the same supporting material in definite relative positions. Depending on the arrangement of the grids, we have rectangular, Delta and T-delta rosettes. The gauges are to be aligned in principal directions.  $\theta$  is the angle of reference measured positive in counter clockwise direction. The strain gauges can be arranged in combination to get three element rectangular rosettes or three element delta rosette or four element rectangular rosettes.

**SETUP:** The set up consists of L-bracket in which bottom plate is fixed rig on the table and vertical plate holds the specimen. One end of the specimen is rigidly fixed by means of screws. Other end of specimen is fixed with loading arm. Strain gauges are mounted on specimen in the form of three element rectangular rosettes. Strain gauge outputs are taken out through connectors. These outputs are connected to the corresponding channels of strain indicator. Strain indicator is provided with three independent displays for each gauge separate zero and calibration provision is made individually.

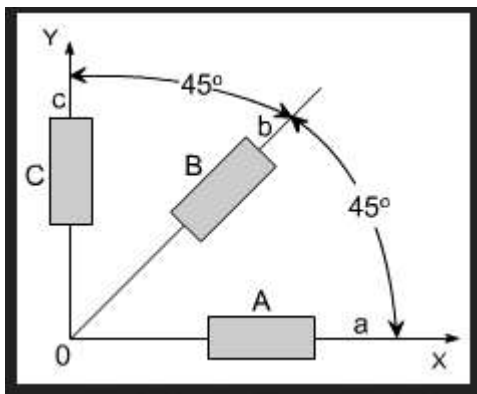

Fig. Three Element Rectangular Rosette.

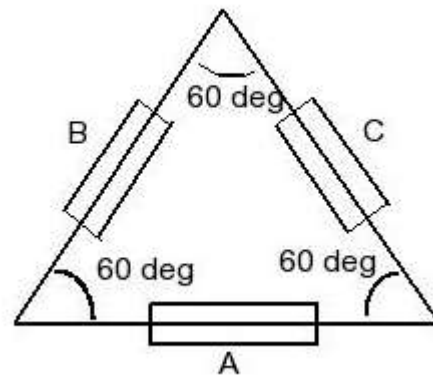

Fig. Delta rosette



Fig: Strain gauge rosette experimental setup

### OBSERVATION:

1. Material of the specimen : Mild steel
2. Diameter of the specimen,  $d$  : ..... mm
3. Length of the torque arm,  $L$  : ..... mm
4. Modulus of Elasticity,  $E$  : ..... GPa
5. Modulus of Rigidity,  $G$  : ..... Gpa
6. Poisson's ratio,  $\nu$  : .....
7. Length of the hallow shaft,  $l$  : ..... mm

**TABULAR COLUMN:**

Sl No	Load in N	Strain Indicator readings in microns			Component strains in microns			Principal strain in microns		Principal Stress (MPa)		Max Shear stress in MPa	Max shear strain
		$\epsilon_A$	$\epsilon_B$	$\epsilon_C$	$\epsilon_x$	$\epsilon_y$	$\gamma_{xy}$	$\epsilon_1$	$\epsilon_2$	$\sigma_1$	$\sigma_2$	$\tau_{max}$	$\gamma_{max}$

**FORMULAE:**

- Component strains for Three element Rectangular rosette in microns

$$\epsilon_x = \epsilon_A, \quad \epsilon_y = \epsilon_C, \quad \gamma_{xy} = 2 \epsilon_B - \epsilon_A - \epsilon_C$$

- Component strains for Delta rosette in microns

$$\epsilon_x = \epsilon_A, \quad \epsilon_y = (1/3)*[-\epsilon_A + 2 \epsilon_B + 2 \epsilon_C], \quad \gamma_{xy} = (2/\sqrt{3})*(\epsilon_B - \epsilon_C)$$

- Principal Strains in microns

$$\epsilon_{1,2} = (\epsilon_x + \epsilon_y)/2 \pm (1/2)*\sqrt{((\epsilon_x - \epsilon_y)^2 + \gamma_{xy}^2)}$$

- Principal stresses in N/mm<sup>2</sup>

$$\sigma_1 = (E/(1-\nu^2))*(\epsilon_1 + \nu \epsilon_2)$$

$$\sigma_2 = (E/(1-\nu^2))*(\epsilon_2 + \nu \epsilon_1)$$

5. Maximum Shear strain in microns

$$\gamma_{\max} = \sqrt{(\epsilon_x + \epsilon_y)^2 + \gamma_{xy}^2}$$

6. Maximum shear stress in N/mm<sup>2</sup>

$$\tau_{\max} = (E / 2(1 + \nu)) * \gamma_{\max}$$

---

## VIVA QUESTIONS

1. What is vibration and what are the causes of vibration?
2. Classify the different types of vibration.
3. What is Free and forced vibration?
4. What is damped and un-damped vibration?
5. What is critical speed of a shaft and what is its importance?
6. What is a bearing? and classify the bearings?
7. What is the difference between hydrodynamic and hydrostatic bearing?
8. Sketch the variation of pressure in the converging film in journal bearing?
9. What are the properties of bearing material?
10. What are the properties of lubricant?
11. Differentiate dynamic and kinematic viscosity?
12. What is bearing characteristics number?
13. Plot the variation of coefficient of friction with bearing characteristics and identify the important regions?
14. What is the summerfield number?
15. At very high speed which one is preferred –journal or ball bearing?
16. Discuss pressure distribution in journal bearing?
17. Express state of strain at any point on the free surface of a body using Cartesian co-ordinate?
18. How strain gauges are are classified?
19. What are the main advantages of electric resistance strain gauges?
20. What are the applications of strain gauges?
21. Define strain sensitivity of a strain gauges?
22. How strain gauges rosettes are specified? Give example
23. Write basic torque equation and give an expression for shear stress?
24. Write basic bending equation and give an expression for bending stress?
25. Give expressions for principal stresses in terms of Cartesian stresses?
26. Give expressions for principal strain in terms of Cartesian strain?
27. What is the nature of light?
28. Define wave front and disturbance?

29. What are the requirements of a photo elastic material?
30. Name few of the photo elastic material.
31. What is polariscope? How many types are there?
32. What is polarizer?
33. What is the difference between polarizer and analyzer.
34. What is a fringe order? What do you understand birefrigerent materials. Can you name few such materials?
35. What is a fringe constant?
36. What is a wave plate how are they classified?
37. What are the advantages of photo elasticity over other experimental techniques?
38. What is meant by polarized light?
39. What are the elements of circular polariscope?
40. What is meant by polarizer, analyzer, quarter wave plate, half wave plate?
41. How can we produce dark field and bright field arrangement using circular polariscope.
42. Difference between isochromatics and isoclinics.
43. What are the methods used for determining the fractional fringe order.
44. What is scattered light photo elasticity?
45. Explain oblique incidence method.
46. Explain why stress concentration occurs at inner fiber of curved beams.
47. What is fringe Multiplication factor?