

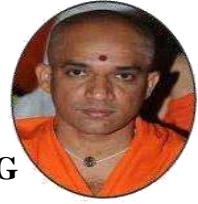

||JAI SRI GURUDEV||



S J C INSTITUTE OF TECHNOLOGY
DEPARTMENT OF INFORMATION SCIENCE & ENGINEERING



ANALOG AND DIGITAL ELECTRONICS LABORATORY
MANUAL
[18CSL37]
(III SEMESTER)

Prepared By
Nagesh.R
Assistant Prof,
Dept of ISE



VISVESVARAYA TECHNOLOGICAL UNIVERSITY, BELAGAVI
2021-22

DEPARTMENT VISION AND MISSION

VISION

Educating Students to Engineer Information Science and Technology for Advancing the Knowledge as to Best Serve the Real World.

MISSION

The Department of Information Science and Engineering will make every effort to promote an intellectual and an ethical environment in which the strengths and skills of Computer Professionals will flourish by

1. Focusing on Fundamentals and Applied aspects in both Information Science Theory and Programming practices.
2. Training comprehensively and encouraging R&D culture in trending areas of Information Technology.
3. Collaborating with premier Institutes and Industries to nurture Innovation and learning, in cutting edge Information Technology.
4. Educating and preparing the students who are much Sought-after, Productive and Well-respected for their work culture having Lifelong Learning practice.
5. Promoting ethical and moral values among the students so as to enable them emerge as responsible professionals.

State the Program Educational Objectives (PEOs) (5)

The PEOs of ISE program describe accomplishments that graduates are expected to attain within three-five years after graduation. Graduates would have applied their expertise to contemporary problem solving, be engaged professionally, have continued to learn & adapt, and have contributed to their organizations through leadership & teamwork.

ISE Graduates within three-five years of graduation should:

1. Engage in Successful professional career in Information Science and Technology.
2. Pursue higher studies and research to advance the knowledge for Solving Contemporary Problems in IT industry.
3. Adapt to a constantly changing world through Professional Development and Sustained Learning.
4. Exhibit professionalism and team work with social concern.
5. Develop Leadership and Entrepreneurship Skills by incorporating organizational goals.

State the Program Specific Outcomes (PSOs)

1. Apply the knowledge of data structures, database systems, system programming, networking, web development and AI & ML techniques in engineering the software.
2. Exhibit solid foundations and advancements in developing software / hardware systems for solving contemporary problems.

Program Outcomes as defined by NBA (PO): Engineering Graduates will be able to:

1. **Engineering knowledge:** Apply the knowledge of mathematics, science, engineering fundamentals, and an engineering specialization to the solution of complex engineering problems.
2. **Problem analysis:** Identify, formulate, review research literature, and analyze complex engineering problems reaching substantiated conclusions using first principles of mathematics, natural sciences, and engineering sciences.
3. **Design/development of solutions:** Design solutions for complex engineering problems and design system components or processes that meet the specified needs with appropriate consideration for the public health and safety, and the cultural, societal, and environmental considerations.
4. **Conduct investigations of complex problems:** Use research-based knowledge and research methods including design of experiments, analysis and interpretation of data, and synthesis of the information to provide valid conclusions.
5. **Modern tool usage:** Create, select, and apply appropriate techniques, resources, and modern engineering and IT tools including prediction and modeling to complex engineering activities with an understanding of the limitations.
6. **The engineer and society:** Apply reasoning informed by the contextual knowledge to assess societal, health, safety, legal and cultural issues and the consequent responsibilities relevant to the professional engineering practice.
7. **Environment and sustainability:** Understand the impact of the professional engineering solutions in societal and environmental contexts, and demonstrate the knowledge of, and need for sustainable development.
8. **Ethics:** Apply ethical principles and commit to professional ethics and responsibilities and norms of the engineering practice.
9. **Individual and team work:** Function effectively as an individual, and as a member or leader in diverse teams, and in multidisciplinary settings.
10. **Communication:** Communicate effectively on complex engineering activities with the engineering community and with society at large, such as, being able to comprehend and write effective reports and design documentation, make effective presentations, and give and receive clear instructions.
11. **Project management and finance:** Demonstrate knowledge and understanding of the engineering and management principles and apply these to one's own work, as a member and leader in a team, to manage projects and in multidisciplinary environments.
12. **Life-long learning:** Recognize the need for, and have the preparation and ability to engage in independent and life-long learning in the broadest context of technological change.

Course objectives:

This laboratory course enables students to get practical experience in design, assembly and evaluation/testing of

- Analog components and circuits including Operational Amplifier, Timer, etc.
- Combinational logic circuits.
- Flip - Flops and their operations
- Counters and registers using flip-flops.
- Synchronous and Asynchronous sequential circuits.
- A/D and D/A converters

Course Outcomes:

The student should be able to:

- Use appropriate design equations / methods to design the given circuit.
- Examine and verify the design of both analog and digital circuits using simulators.
- Make use of electronic components, ICs, instruments and tools for design and testing of circuits for the given the appropriate inputs.
- Compile a laboratory journal which includes; aim, tool/instruments/software/components used, design equations used and designs, schematics, program listing, procedure followed, relevant theory, results as graphs and tables, interpreting and concluding the findings.

Descriptions (if any)

- Simulation packages preferred: Multisim, Modelsim, PSpice or any other relevant.
- Continuous evaluation by the faculty must be carried by including performance of a student in both hardware implementation and simulation (if any) for the given circuit.
- A batch not exceeding 4 must be formed for conducting the experiment. For simulation individual student must execute the program.

Laboratory Programs

PART A (Analog Electronic Circuits)

1. Design an astable multivibrator circuit for three cases of duty cycle (50%, <50% and >50%) using NE 555 timer IC. Simulate the same for any one duty cycle.
2. Using ua 741 Opamp, design a 1 kHz Relaxation Oscillator with 50% duty cycle. And simulate the same.
3. Using ua 741 opamp, design a window comparator for any given UTP and LTP. And simulate the same.

PART B (Digital Electronic Circuits)

4. Design and implement Half adder, Full Adder, Half Subtractor, Full Subtractor using basic gates. And implement the same in HDL.
5. Given a 4-variable logic expression, simplify it using appropriate technique and realize the simplified logic expression using 8:1 multiplexer IC. And implement the same in HDL.
6. Realize a J-K Master / Slave Flip-Flop using NAND gates and verify its truth table. And implement the same in HDL.
7. Design and implement code converter I) Binary to Gray (II) Gray to Binary Code using basic gates.
8. Design and implement a mod-n ($n < 8$) synchronous up counter using J-K Flip-Flop ICs and demonstrate its working.
9. Design and implement an asynchronous counter using decade counter IC to count up from 0 to n ($n \leq 9$) and demonstrate on 7-segment display (using IC-7447)

Experiment Beyond the syllabus.

S.No	Title of experiment	POs	PSOs
1	Design of comparing 2 numbers using combinational circuit.	9,11,12	1,2
2	Realize the sequence detector using shift register.		

Conduct of Practical Examination:

Experiment distribution

- For laboratories having PART A and PART B: Students are allowed to pick one experiment from PART A and one experiment from PART B, with equal opportunity.
- Change of experiment is allowed only once and marks allotted for procedure to be made zero of the changed part only.
- For laboratories having PART A and PART B (Marks Allocation)

Part A – Procedure + Execution + Viva = 6 + 28 + 6 = 40 Marks

Part B – Procedure + Execution + Viva = 9 + 42 + 9 = 60 Marks

PART - A

Analog Electronics Experiments

1. Design an astable multivibrator circuit for three cases of duty cycle (50%, <50% and >50%) using NE 555 timer IC. Simulate the same for any one duty cycle.

Description:

Multivibrator is a form of oscillator, which has a non-sinusoidal output. The output waveform is rectangular. The multivibrators are classified as

i) Astable or free running multivibrator It alternates automatically between two states (low and high for a rectangular output) and remains in each state for a time dependent upon the circuit constants. It is just an oscillator as it requires no external pulse for its operation.

ii) Monostable or one shot multivibrators: It has one stable state and one quasi stable. The application of an input pulse triggers the circuit time constants and the output goes to the quasi stable state, after a period of time determined by the time constant, the circuit returns to its initial stable state. The process is repeated upon the application of each trigger pulse.

iii) Bistable Multivibrators: It has both stable states. It requires the application of an external triggering pulse to change the output from one state to other. After the output has changed its state, it remains in that state until the application of next trigger pulse. Flip flop is an example.

Components Required:

555 Timer IC, Resistors of 3.3K Ω , 6.8K Ω , Capacitors of C=0.1 μ F, C'=0.01 μ F, digital trainer kit(used to give +5v power supply to 555 IC),CRO.

Design:

For astable multivibrator

$$T_{ON} = 0.693 (R_A + R_B) C$$

$$T_{OFF} = 0.693 R_B C$$

With the diode connected in parallel with R_B the effect of R_B is shunted during charging of the capacitor, therefore the equations for T_{ON} and T_{OFF} is given by

$$T_{ON} = 0.693 R_A C$$

$$T_{OFF} = 0.693 R_B C$$

Case 1: 50% duty cycle

Let Frequency = 1kHz, T=1ms, C=0.1 μ F

$$T_{ON} = T_{OFF} = 0.5\text{ms}$$

$$\text{For } R_A, 0.5\text{ms} = 0.693 * R_A * 0.1 * 10^{-6}$$

$$R_A = 7.2 \text{ k}\Omega = R_B$$

Case 2: >50% duty cycle, let Duty cycle be 75%

Let Frequency = 1kHz, T=1ms, C=0.1 μ F

$$T_{ON} = 0.75\text{ms}$$

$$T_{OFF} = 0.25\text{ms}$$

$$\text{For } R_A, 0.75\text{ms} = 0.693 * R_A * 0.1 * 10^{-6}$$

$$R_A = 10 \text{ k}\Omega$$

$$\text{For } R_B, 0.25\text{ms} = 0.693 * R_B * 0.1 * 10^{-6}$$

$$R_B = 3.6 \text{ k}\Omega$$

Case 3: <50% duty cycle, let Duty cycle be 25%

Let Frequency = 1kHz, T=1ms, C=0.1 μF

T_{ON} = 0.25ms

T_{OFF} = 0.75ms

For R_A, 0.25ms = 0.693 * R_A * 0.1 * 10⁻⁶

R_A = 3.6 kΩ

For R_B, 0.75ms = 0.693 * R_B * 0.1 * 10⁻⁶

R_B = 10 kΩ

Circuit Diagram:

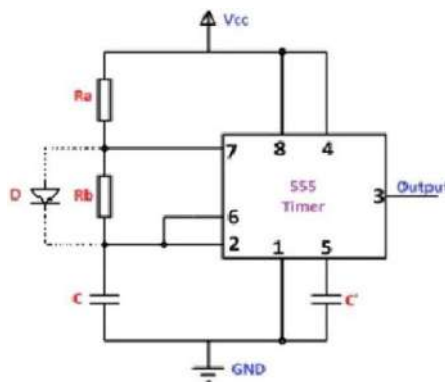

Figure 1: astable mutivibrator

Connect the pin 2 to the CRO to get the capacitor waveform check the amplitude from the waveform to get the UTP and LTP values.

Connect pin 3 to CRO to get the output. Find out the T_H and T_L values.

Procedure:

1. Before making the connections, check the components using multimeter.
2. Make the connections as shown in figure and switch on the power supply.
3. Observe the capacitor voltage waveform at 6th pin of 555 timer on CRO.
4. Observe the output waveform at 3rd pin of 555 timer on CRO (shown below).
5. Note down the amplitude levels, time period and hence calculate duty cycle.

The V_{cc} determines the upper and lower threshold voltages (observed from the capacitor voltage waveform) as . $V_{UT} = \frac{2}{3}V_{cc} \wedge V_{LT} = \frac{1}{3}V_{cc}$.

Result:

The frequency of the oscillations = 1KHz.

Output Waveforms

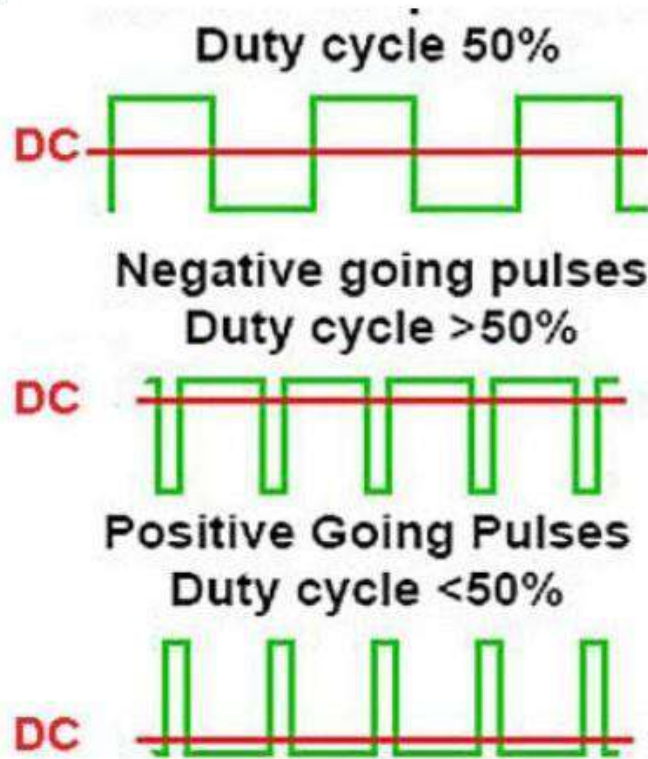

Figure 2: astable multivibrator output waveforms

Result:

Note:

Each division in oscilloscope is 0.2

Time=no of div in x-axis x time base

Amplitude= no of div in y-axis x volt/div

Duty cycle= $(T_{on}/T_{on} + T_{off}) * 100$

Duty cycle	Duty cycle	Ton	Toff
Theoretical	50%	0.5ms	0.5ms
	75%	0.75ms	0.25ms
	25%	0.25ms	0.75ms
Practical	50%		
	75%		
	25%		

Simulation:

Circuit diagram: Astable multivibrator for duty cycle >50%

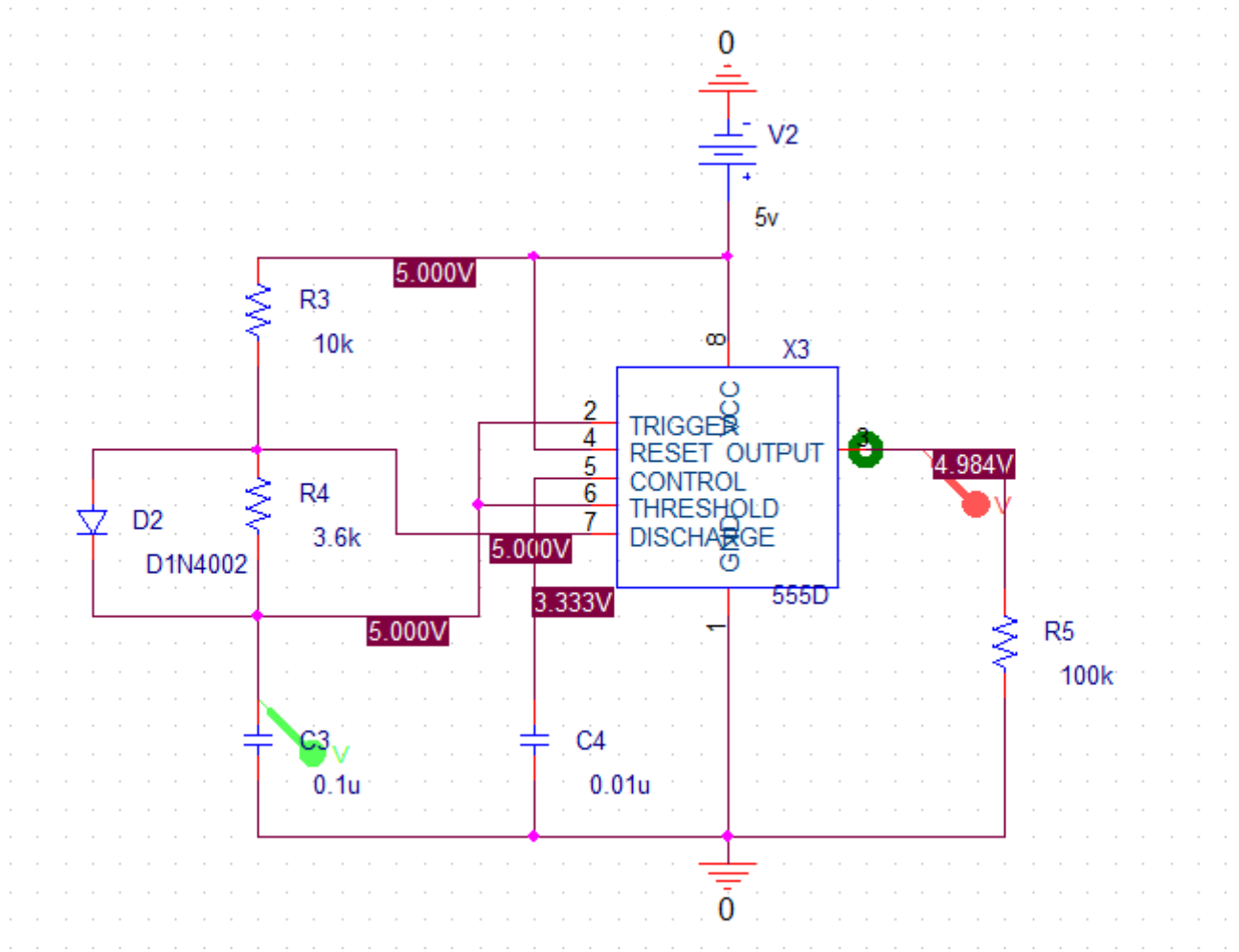

Output waveform:

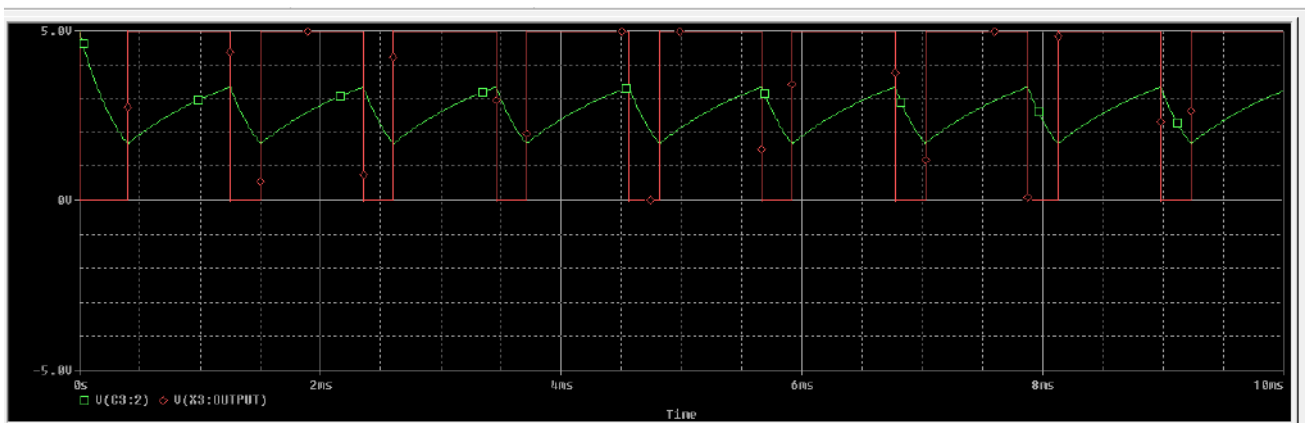

Type of analysis: TIME DOMAIN (TRANSIENT)

Run to time: 10m

Step size: 0.01m

Viva Voce Questions	Blooms Taxonomy Level
1. What is a multivibrators?	1. L2
2. What is a bistable multivibrators?	2. L2
3. Give the applications of monostable and astable multivibrators	3. L2
4. Explain the working of 555 timer as astable and monostable multivibrator	4. L2
5. Why astable multivibrator is called as free running multivibrato	5. L3
6. Define duty cycle.	6. L2
7. List the applications of 555 timer	7. L2

2.Using ua 741 Opamp, design a 1 kHz Relaxation Oscillator with 50% duty cycle. And simulate thesame.

Components required: Op-amp μA 741, Resistor of $1K\Omega$, $10K\Omega$, $20 k\Omega$ Potentiometer, Capacitor of $0.1 \mu F$, Fixed DC power supply $\pm 12v$, CRO, connecting board.

Design: The period of the output rectangular wave is given as $T = 2RC \ln \left(\frac{1 + \beta}{1 - \beta} \right)$ ----- (1)

Where, $\beta = \frac{R_1}{R_1 + R_2}$ is the feedback fraction

If $R_1 = R_2$, then from equation (1) we have $T = 2RC \ln(3)$

Another example, if $R_2 = 1.16 R_1$, then $T = 2RC$ ----- (2)

Example: Design for a frequency of 1kHz (implies $T = \frac{1}{f} = \frac{1}{10^3} = 10^{-3} = 1ms$)

Use $R_2 = 1.16 R_1$, for equation (2) to be applied.

Let $R_1 = 10k\Omega$, then $R_2 = 11.6k\Omega$ (use $20k\Omega$ potentiometer as shown in circuit figure)

Choose next a value of C and then calculate value of R from equation (2).

Let $C = 0.1 \mu F$ (i.e., 10^{-7}), then $R = \frac{T}{2C} = \frac{10^{-3}}{2 \times 10^{-7}} = 5K\Omega$

The voltage across the capacitor has a peak voltage of $V_c = \frac{R_1}{R_1 + R_2} V_{sat}$

Procedure :

1. Before making the connections check all the components using multimeter.
2. Make the connections as shown in figure and switch on the power supply.
3. Observe the voltage waveform across the capacitor on one of the channel on CRO.
4. Also observe the output waveform at pin 6 on another channel of CRO. Measure its amplitude and time & find frequency.

NOTE: There is no I/P signal in this circuit.

Circuit Diagram:

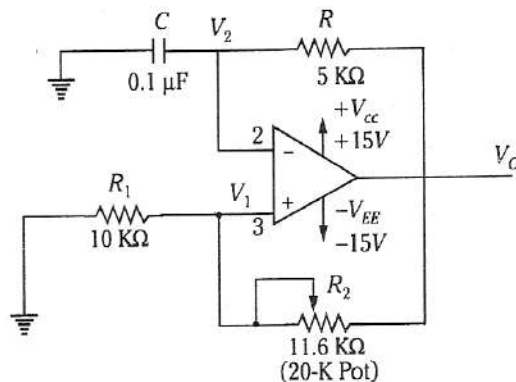

Values
$C = 0.1 \mu F$
$R_1 = 10 k\Omega$
$R_2 = 11.6 k\Omega$
$R = 4.7k/5.1k\Omega$

Waveforms

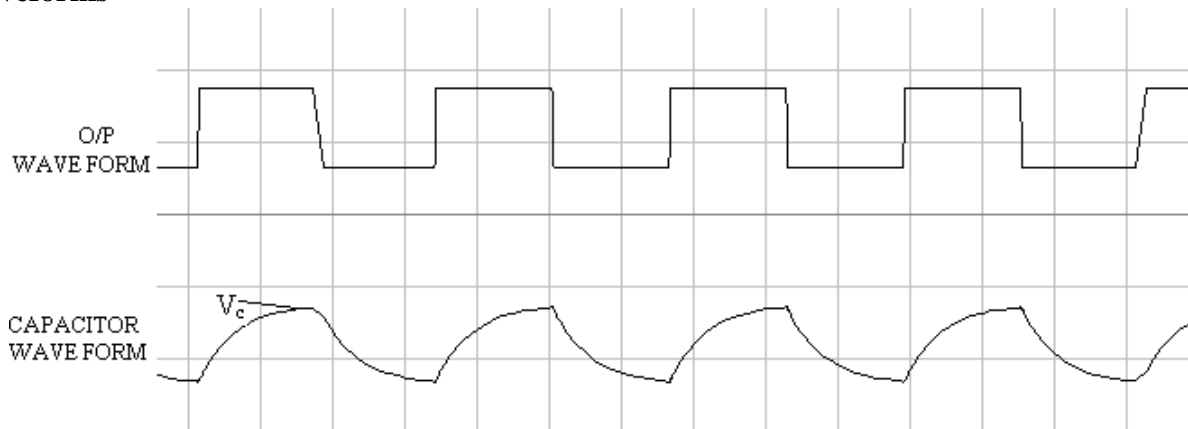

Theory:

Op-Amp Relaxation Oscillator is a simple Square wave generator which is also called as a Free running oscillator or Astable multivibrator or Relaxation oscillator. In this figure the op-amp operates in the saturation region. Here, a fraction $(R2/(R1+R2))$ of output is fed back to the noninverting input terminal. Thus reference voltage is $(R2/(R1+R2)) V_o$. And may take values as $+(R2/(R1+R2)) V_{sat}$ or $-(R2/(R1+R2)) V_{sat}$. The output is also fed back to the inverting input terminal after integrating by means of a low-pass RC combination. Thus whenever the voltage at inverting input terminal just exceeds reference voltage, switching takes place resulting in a square wave output.

Result: The frequency of the oscillations = ____ Hz.

Simulation:

Circuit diagram: Relaxation oscillator

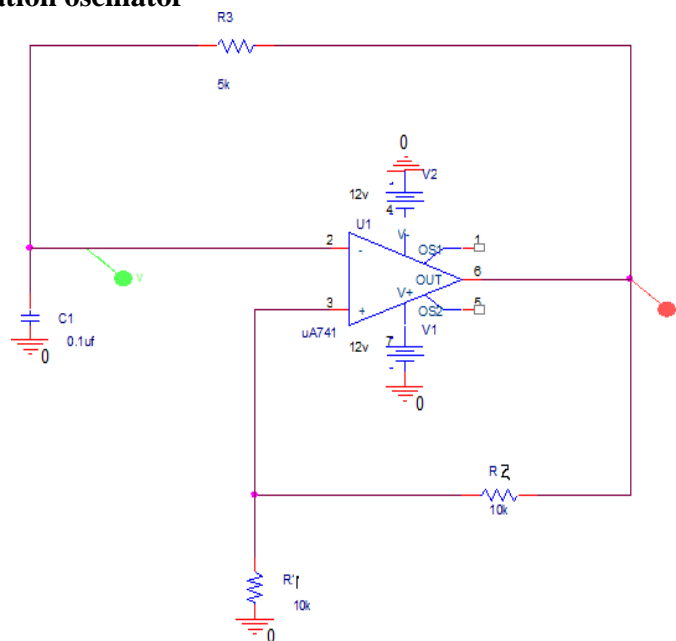

Waveforms from simulation T= 1ms f=1khz

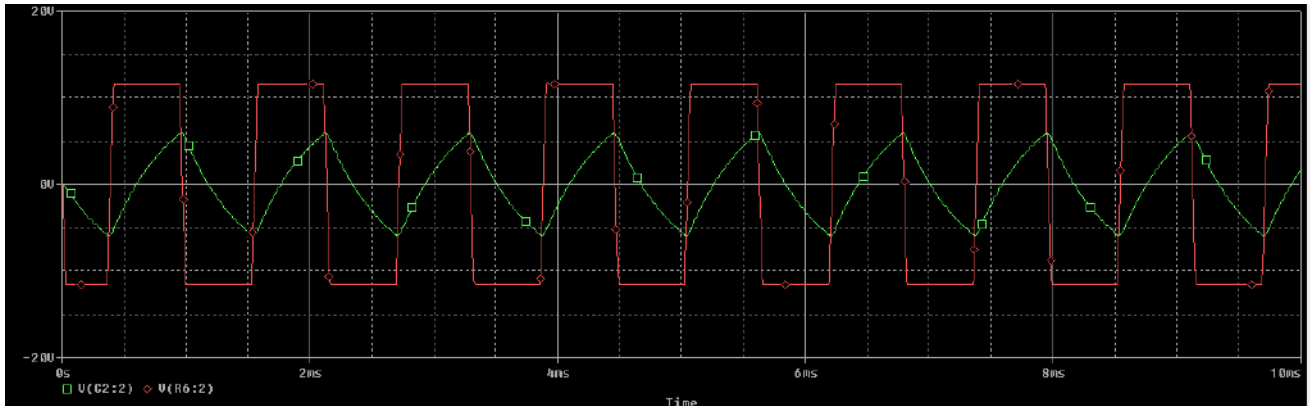

Type of analysis: TIME DOMAIN (TRANSIENT)

Run to time: 10m

Step size: 0.01m

Viva Voce Questions	Blooms Taxonomy Level
1. Why operational amplifier is called by its name?	1. L3
2. Explain the advantages of OPAMP over transistor amplifiers.	2. L2
3. List the OPAMP ideal characteristics.	3. L2
4. Give the symbol of OPAMP	4. L2
5. Explain the various applications of OPAMP	5. L2
6. What is a square wave generator/ Regenerative comparator?	6. L2
7. What is a bipolar and unipolar devices? Give examples	7. L2

3.Using ua741 Op-amp, design window comparator for any given UTP and LTP. And simulate thesame.

Description:

A Window Comparator is basically the inverting and the non-inverting comparators combined into a single comparator stage. The window comparator detects input voltage levels that are within a specific band or window of voltages, instead of indicating whether a voltage is greater or less than some preset or fixed voltage reference point.

This time, instead of having just one reference voltage value, a window comparator will have two reference voltages implemented by a pair of voltage comparators. One which triggers an op-amp comparator on detection of some upper voltage threshold, $V_{REF(UPPER)}$ and one which triggers an op-amp comparator on detection of a lower voltage threshold level, $V_{REF(LOWER)}$. Then the voltage levels between these two upper and lower reference voltages is called the “window”, hence its name.

Components Required:

Two Op amp IC μA 741, Two diode 1N4007, Resistor of $1K\Omega$, DC regulated power Supply, trainer kit (+12v & -12v is given to Op amp from this), Signal generator, CRO.

Circuit:

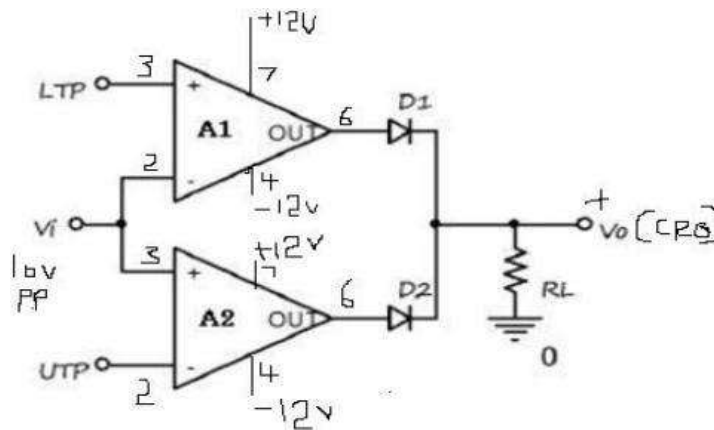

Circuit Diagram for Window comparator

Output waveform

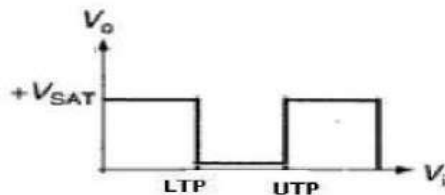

Simulation:

Components to be placed in the schematic:

Two Op amp IC $\mu A 741$, Two diode 1N4007, Resistor of $1K\Omega$, DC regulated power Supply, trainer kit (+12v & -12v is given to Op amp from this).

UTP =3V, LTP = -3V

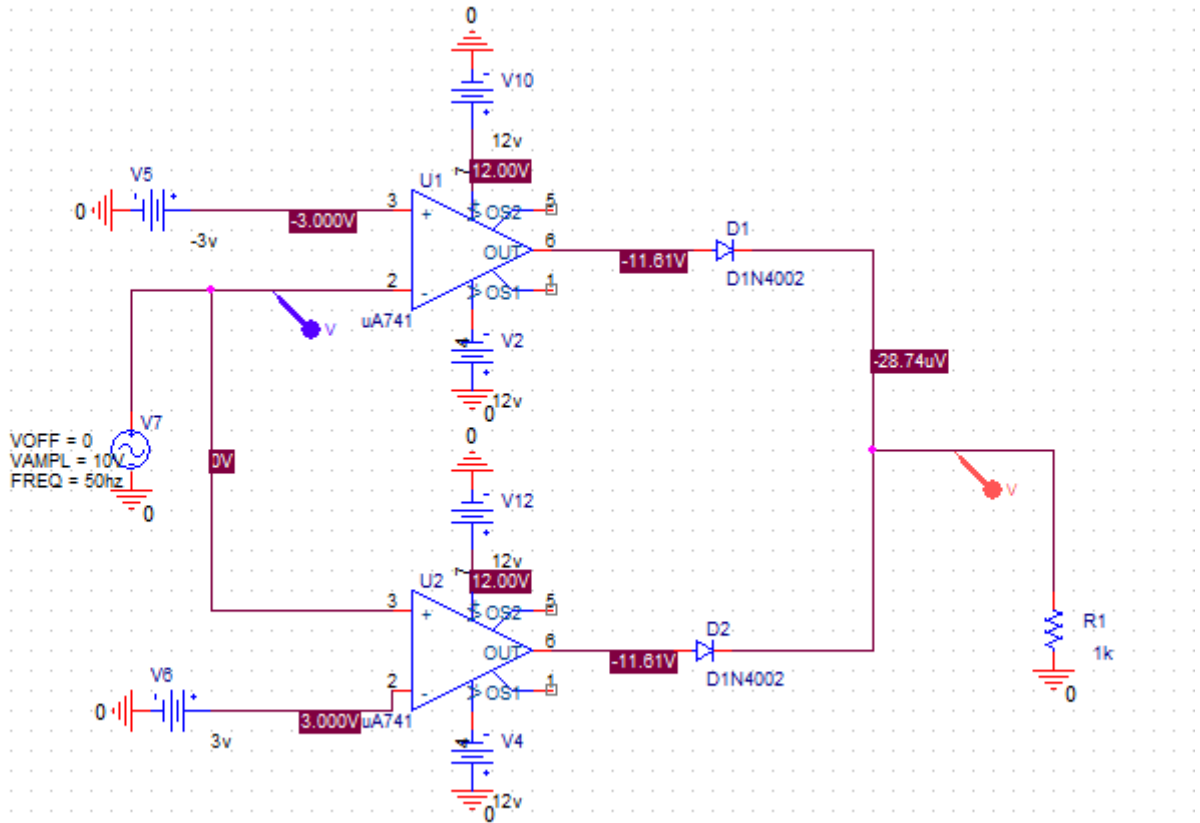

Output waveform:

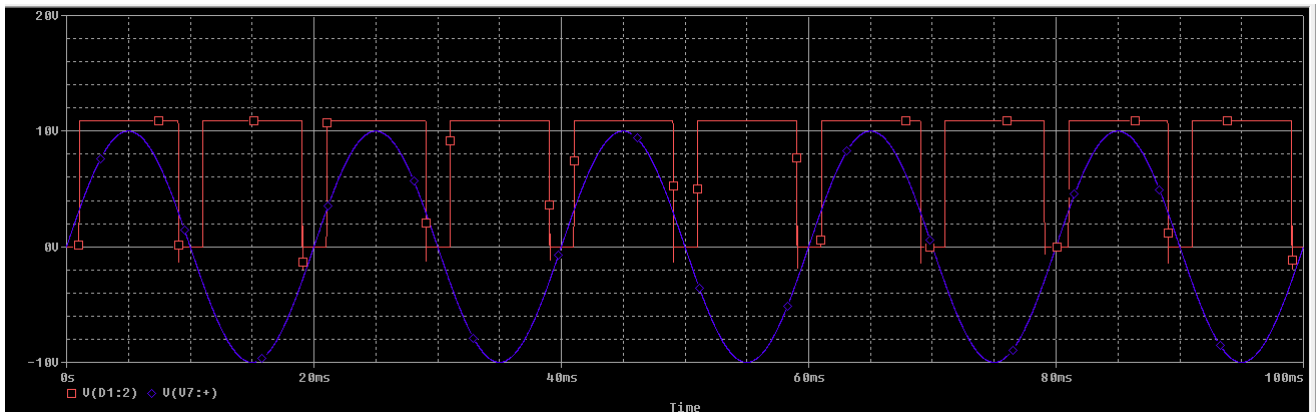



Viva Voce Questions	Blooms Taxonomy Level
1. Define UTP and LTP 2. Mention the applications of schmitt trigger 3. What is a square wave generator/ Regenerative comparator? 4. Give the hysteresis curve of a schmitt trigger	1.L2 2.L2 3.L2 4.L2

PART - B

DIGITAL ELECTRONICS EXPERIMENTS

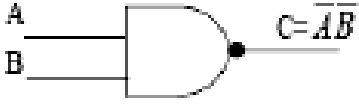
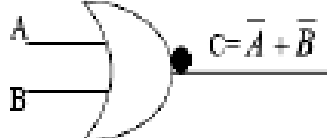
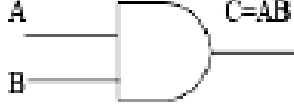
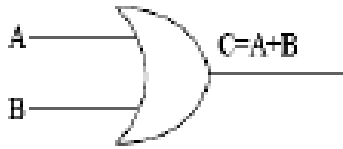
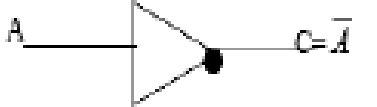
BASIC GATES

S.NO	GATE	SYMBOL	INPUTS		OUTPUT
			A	B	C
1.	NAND IC 7400		0	0	1
			0	1	1
			1	0	1
			1	1	0
2.	NOR IC 7402		0	0	1
			0	1	0
			1	0	0
			1	1	0
3.	AND IC 7408		0	0	0
			0	1	0
			1	0	0
			1	1	1
4.	OR IC 7432		0	0	0
			0	1	1
			1	0	1
			1	1	1
5.	NOT IC 7404		1	-	0
			0	-	1
6.	EX-OR IC 7486		0	0	0
			0	1	1
			1	0	1
			1	1	0

PIN DIAGRAMS & ICs

<p>7404 –NOT GATE</p>	<p>7432(2 INPUT OR GATE)</p>	<p>Pin Diagram Of 7432(2 Input OR Gate)</p>
		<p>2 INPUT OR GATE</p>
<p>4075(3 INPUT OR GATE)</p>	<p>7408(2 INPUT AND)</p>	<p>Pin Diagram Of 7411(3 Input AND Gate)</p>
<p>Dual 3 input or gate M54HC4075</p>		<p>3 INPUT AND GATE</p>

<p>7411(3 INPUT AND)-ICs</p>	<p>7421(4 INPUT AND)</p> <p style="text-align: center;">4 INPUT AND GATE</p>	<p>4 Input OR Gate</p> <p style="text-align: center;">(TOP VIEW)</p> <p style="text-align: center;">DUAL 4-INPUT OR GATE M74HC4072</p>
<p>7402(2 Input NOR Gate)</p> <p style="text-align: center;">(TOP VIEW)</p>	<p>7400(2 Input NAND Gate)</p>	<p>7410(3 Input NAND Gate)</p>
<p>7420(4 input NAND Gate)</p>	<p>7-Segment Decoder</p> <p style="text-align: center;">Pin diagram of 7447</p>	<p>Asynchronous Counter</p> <p style="text-align: center;">Pin diagram of 7490</p>

4.Design and implement Half adder, Full Adder, Half Subtractor, Full Subtractor using basic gates. And implement the same using HDL.

HALF ADDER:

For designing a half adder logic circuit, we first have to draw the truth table for two input variables i.e. the augend and addend bits, two outputs variables carry and sum bits. In first three binary additions, there is no carry hence the carry in these cases are considered as 0.

TRUTH TABLE FOR HALF ADDER:

Inputs		Outputs	
Augend (A)	Addend (B)	Carry (C)	Sum (S)
0	0	0	0
0	1	0	1
1	0	0	1
1	1	1	0

Kmap for Half Adder Now from this truth table we can draw Kmap for carries and sums separately.

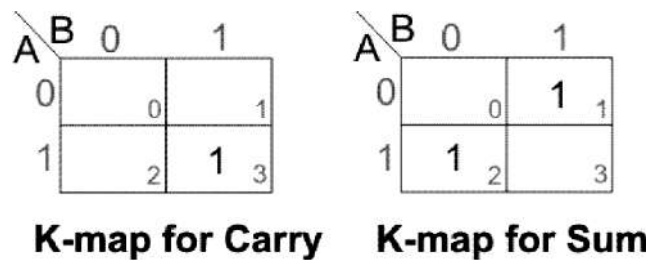

For above K maps we get,

$$\text{Carry } C = AB \text{ and Sum } C = \overline{A}B + A\overline{B}.$$

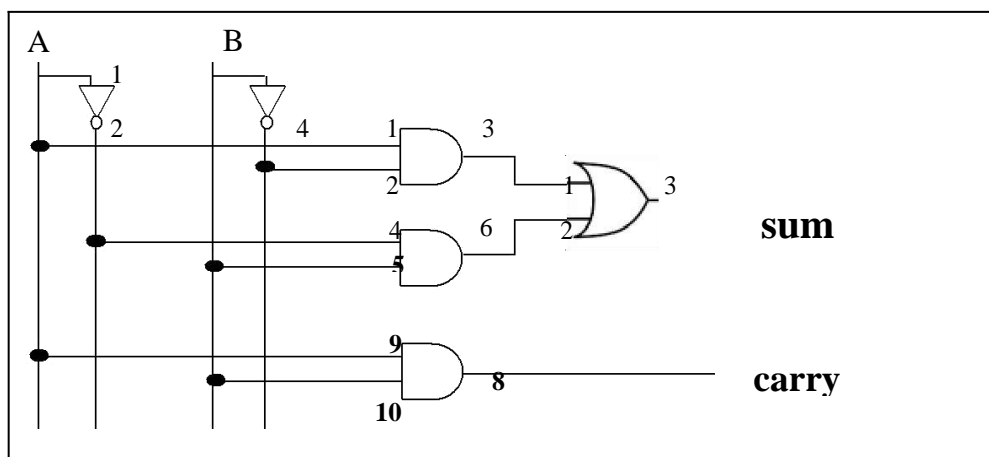

Fig: Logical Circuit design of Half Adder

FULL ADDER:

Full adder is a combitional circuit which performs full binary addition that means it adds two bits and a carry and outputs a sum bit and a carry bit. Any bit of augend can either be 1 or 0 and we can represent with variable A, similarly any bit of addend we represent with variable B. The carry after addition of same significant bit of augend and addend can represent by C.

SLNo	Augend (A)	Addend (B)	Carry (C)	SUM (S)	Final Carry (C _{out})
0	0	0	0	0	0
1	0	0	1	1	0
2	0	1	0	1	0
3	0	1	1	0	1
4	1	0	0	1	0
5	1	0	1	0	1
6	1	1	0	0	1
7	1	1	1	1	1

From the above table, we can draw Kmap for sum (s) and final carry (C_{out}).

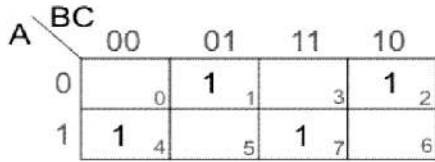

K-map for Sum (S)

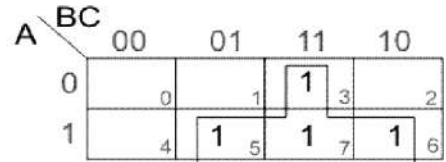

K-map for Carry (C_{out})

$$S = \overline{A} \overline{B} C + \overline{A} B \overline{C} + A \overline{B} \overline{C} + \overline{A} B C$$

$$C = BC + AC + AB$$

Circuit diagram

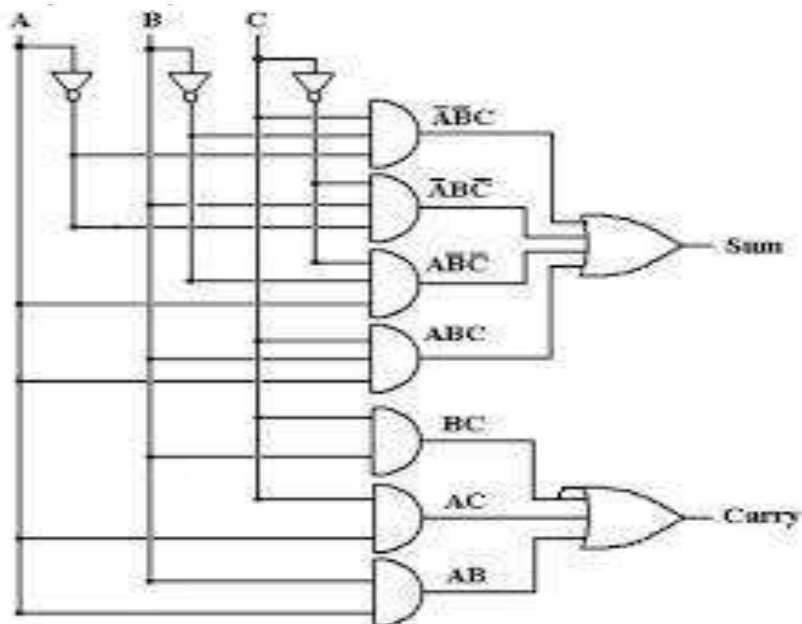

Fig: Circuit diagram of full adder

HALF SUBTRACTOR:

Half subtractor is a combinational circuit which performs subtraction of single bit binary numbers. The subtraction combinations of two single bit binary numbers can be,

Now if we draw a truth table for that, with all differences (D) and borrow (b), we get,

Minuend (A)	Subtrahend (B)	Difference (D)	Borrow (b)
0	0	0	0
0	1	1	1
1	0	1	0
1	1	0	0

Hence, from truth table it is found that,

$$\text{Difference} = A^1B + AB^1 \quad \text{Borrow} = AB$$

The above equations can be represented using logic gates.

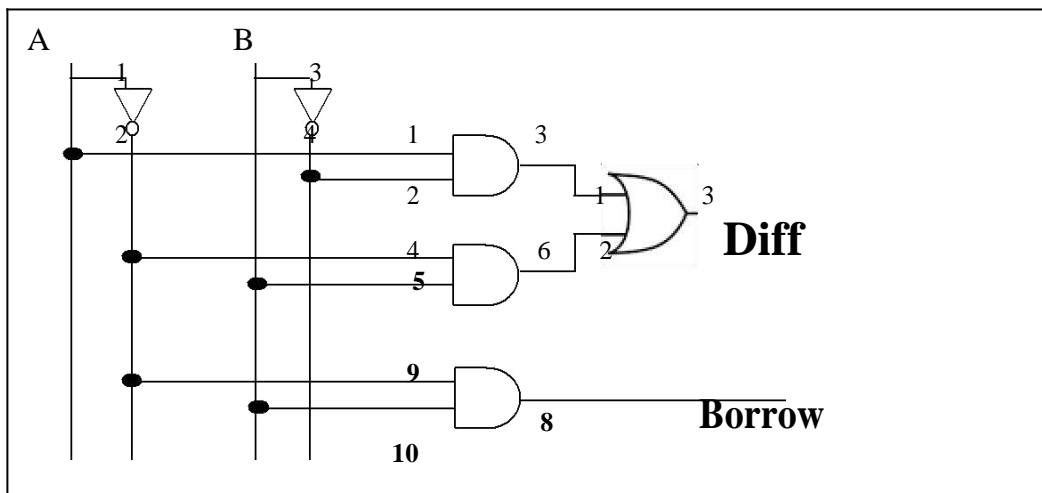

Fig: Circuit diagram of Half subtractor

FULL SUBTRACTOR:

This is not practical to perform subtraction only between two single bit binary numbers. Instead binary numbers are always multibits. The subtraction of two binary numbers is performed bit by bit from right (LSB) to left (MSB). During subtraction of same significant bit of minuend and subtrahend, there may be one borrow bit along with difference bit. This borrow bit (either 0 or 1) is to be added to the next higher significant bit of minuend and then next corresponding bit of subtrahend to be subtracted from this. It will continue up to MSB. The combinational logic circuit performs this operation is called full subtractor. Hence, full subtractor is similar to half subtractor but inputs in full subtractor are three instead of two. Two inputs are for the minuend and subtrahend bits and third input is for borrowed which comes from previous bits subtraction. The outputs of full adder are similar to that of half adder, these are difference (D) and borrow (b). The combination of minuend bit (A), subtrahend bit (B) and input borrow (bi) and their respective differences (D) and output borrows (b) are represented in a truth table, as follows.

Inputs			Outputs	
A	B	Borrow _{in}	Diff	Borrow
0	0	0	0	0
0	0	1	1	1
0	1	0	1	1
0	1	1	0	1
1	0	0	1	0
1	0	1	0	0
1	1	0	0	0
1	1	1	1	1

Simplified using K-Map.

K-Map

Difference

	B Bin			
A	00	01	11	10
0		1		1
1	1		1	

$$D = \overline{A}\overline{B}B_{in} + \overline{A}B\overline{B}_{in} + A\overline{B}\overline{B}_{in} + AB B_{in}$$

$$= B_{in}(\overline{A}\overline{B} + AB) + \overline{B}_{in}(\overline{A}B + A\overline{B})$$

$$= B_{in}(A \odot B) + \overline{B}_{in}(A \oplus B)$$

$$= B_{in} \oplus (A \oplus B)$$

Borrow

	B Bin			
A	00	01	11	10
0		1	1	1
1			1	

$$B_{out} = \overline{A}B + \overline{A}B_{in} + BB_{in}$$

Note: In input, in place of C we have Bin

Circuit diagram

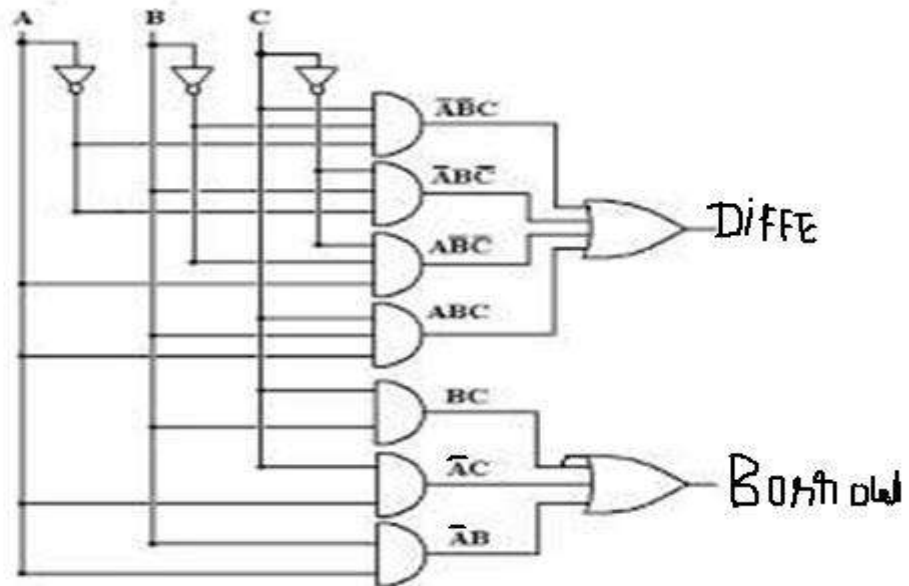
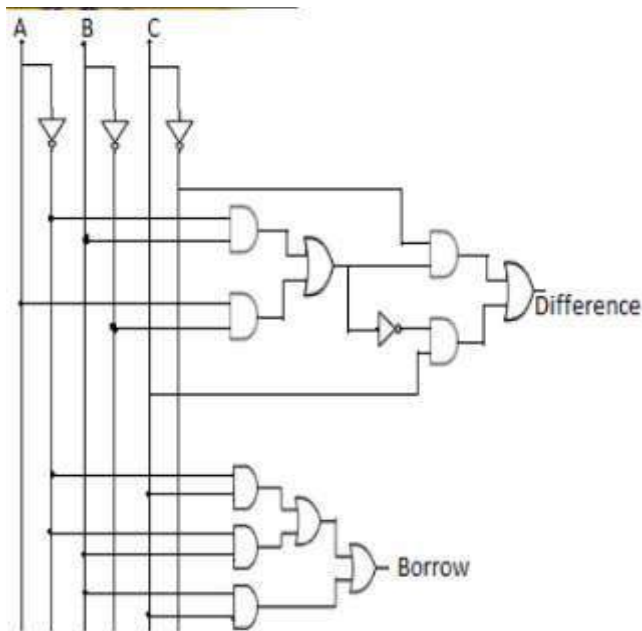

Fig: Circuit diagram of Full Sub tractor

(Below Circuit diagram is a modified circuit diagram for full subtractor without using 4 input OR gate and 3 input AND gate)



RESULT:
Truth table is verified

Simulation:

VHDL code for Adder, Subtractor

```

library ieee;
use ieee.std_logic_1164.all;
entity adder is
    port(a,b,c: in std_logic;
         HAsum, HAcout, FAsum, FAcout, HSdiff, HSborr, FSdiff, FSborr: out std_logic);
end adder;
architecture dataflow of adder is
begin
    HAsum<= a xor b;
    HAcout <= a and b;
    FAsum<= a xor b xor c;
    FAcout <= ((a and b)or(b and c) or(a and c));
    HSdiff<= a xor b;
    HSborr <= (a and (not b));
    FSdiff<= a xor b xor c;
    FSborr <= ((b xor c) and (not a)) or (b and c);
end dataflow;
    
```

Waveform:



Note: File name, project name, entity name should be same

Viva Voce Questions	Blooms Taxonomy Level
1. Define a logic gate.	1. L2
2. What are basic gates?	2. L2
3. Why NAND and NOR gates are called as universal gates?	3. L3
4. State De morgans theorem	4. L2
5. Give examples for SOP and POS	5. L2
6. Explain how transistor can be used as NOT gate	6. L2
7. Realize logic gates using NAND and NOR gates only	7. L3
8. List the applications of EX-OR and EX~NOR gates	8. L2
9. What is a half adder?	9. L2
10. What is a full adder?	10. L2

5. Given any 4-variable logic expression, simplify it using appropriate technique and realize the simplified logic expression using 8:1 multiplexer IC. And implement the same in HDL.

- a) **Example:** Simplify the function using MEV technique

$$F(a,b,c,d) = \sum m(2,3,4,5,13,15) + dc(8,9,10,11)$$

Decimal	LSB	Function	MEV map entry
0} 0 1	0000 0001	0 0	0----- Do
1} 2 3	0010 0011	1 1	1----- D1
2} 4 5	0100 0101	1 1	1----- D2
3} 6 7	0110 0111	0 0	0----- D3
4} 8 9	1000 1001	X X	X----- D4
5} 10 11	1010 1011	X X	X----- D5
6} 12 13	1100 1101	0 1	d----- D6
7} 14 15	1110 1111	0 1	d----- D7

Components Used: IC 74LS151, Patch Chords, Trainer kit.

Pin Diagram of Ics Used:

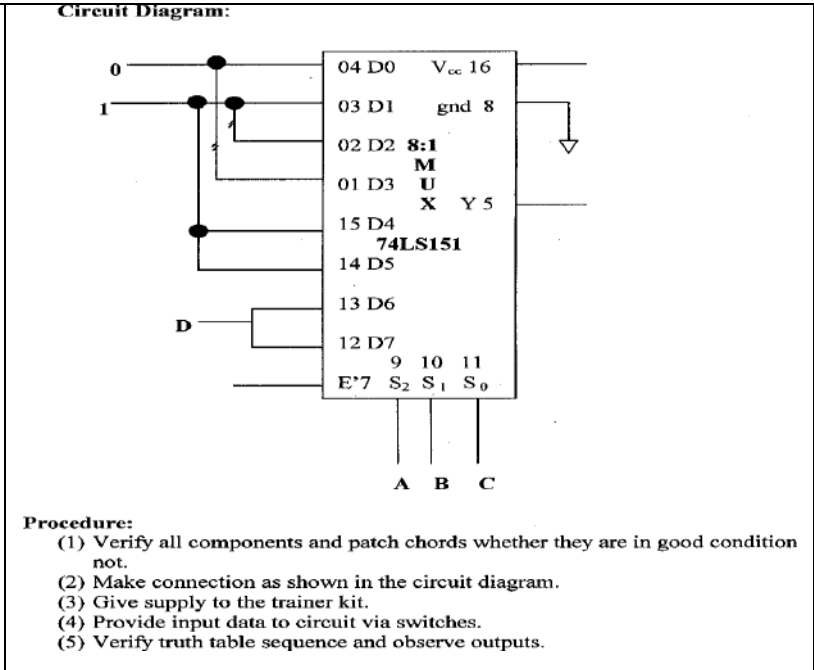
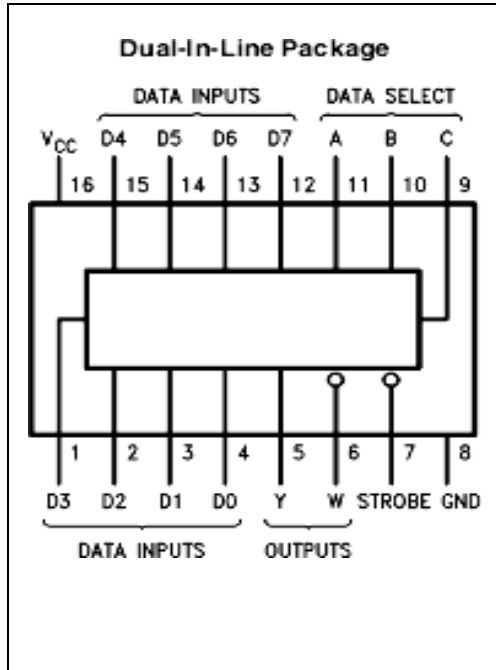

Note: Both pin number 7& 8 should be connected to ground

Theory:

Map Entered Variable Method:

Rules for entering values in a MEV K Map:

Rule No.	MEV f		Entry in MEV Map	Comments
1.	0	0	0	If function equals 0 for both values of MEV, enter 0 in appropriate cell of MEV Map
	1	0		
2	0	1	1	If function equals 1 for both values of MEV, enter 1.
	1	1		
3.	0	0	MEV	If function equals MEV enter MEV
	1	1		
4.	0	1	----- MEV	If the function is compliment of MEV enter MEV.
	1	0		
5.	0	-	-	If function equals don't care for both values of MEV, enter -
	1	-		
6.	0	-	0	If f=0 for MEV=0 and f=0 for MEV=1, enter 0.
	1	0		
7.	0	0	0	If f=0 for MEV=0 and f=- for MEV=1, enter 0.
	1	-		
8.	0	-	1	If f=-for MEV=0 and f=1 for MEV=1, enter 1.
	1	1		
9.	0	1	1	If f=1 for MEV=0 and f=- for MEV=-, enter -.
	1	-		

Result:

Truth Table is verified

Simulation: VHDL code for 8:1 MUX

Description:

An 8:1 multiplexer has 8 inputs and one output. The data stored in one of these 8 input lines is transferred serially to the output based on the value of the selection bits.

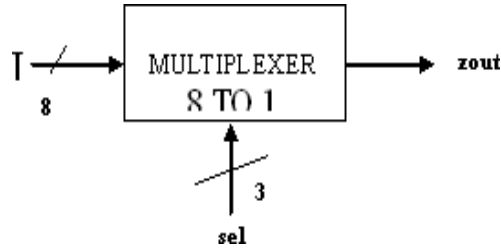

VHDL code for 8 to 1 MUX (behavioral modeling):

```
library IEEE;
use IEEE.STD_LOGIC_1164.ALL; // includes the standard library
entity mux1 is
    Port ( I : in std_logic_vector(7 downto 0);
          sel : in std_logic_vector(2 downto 0); //Input and output is declared as ports
          zout : out std_logic);
end mux1;
architecture Behavioral of mux1 is
begin
    zout<= I(0) when sel="000" else // Based on the value of selection the value of data
    I(1) when sel="001" else //stored in the array I is stored in zout
    I(2) when sel="010" else
    I(3) when sel="011" else
    I(4) when sel="100" else
    I(5) when sel="1
    01" else I(6) when
    sel="110" elseI(7);
end Behavioral;
```

TruthTable

INPUTS			OUTPUTS
SEL (2)	SEL (1)	SEL (0)	Zout
0	0	0	I(0)
0	0	1	I(1)
0	1	0	I(2)
0	1	1	I(3)
1	0	0	I(4)
1	0	1	I(5)
0	1	1	I(6)
1	1	1	I(7)

Waveform:

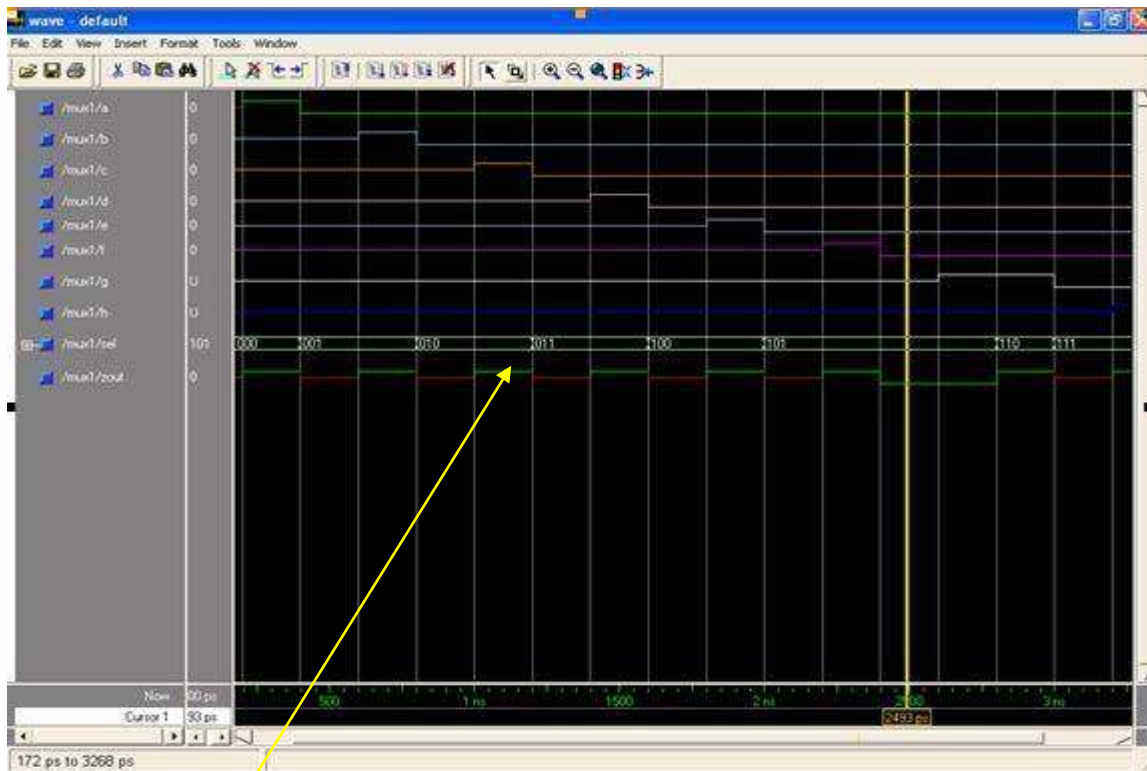

output

Viva Voce Questions	Blooms Taxonomy Level
1. What is multiplexer	1. L2
2. Why it is called as universal LOGIC CIRCUIT	2. L3
3. State De morgans theorem	3. L2
4. Give examples for SOP and POS	4. L2
5. Realize logic gates using NAND and NOR gates only	5. L3
6. List the applications of EX-OR and EX~NOR gates	6. L2
7. Show the design of different value for multiplexer	7. L3

6. Realize a J-K Master/Slave FF using NAND gates and verify its truth table. And implement the same in HDL.

Components used: IC 74LS00, IC 74LS10, IC 74LS20, Power chords, Patch chords, Trainer kit.

Pin Details of the ICs:

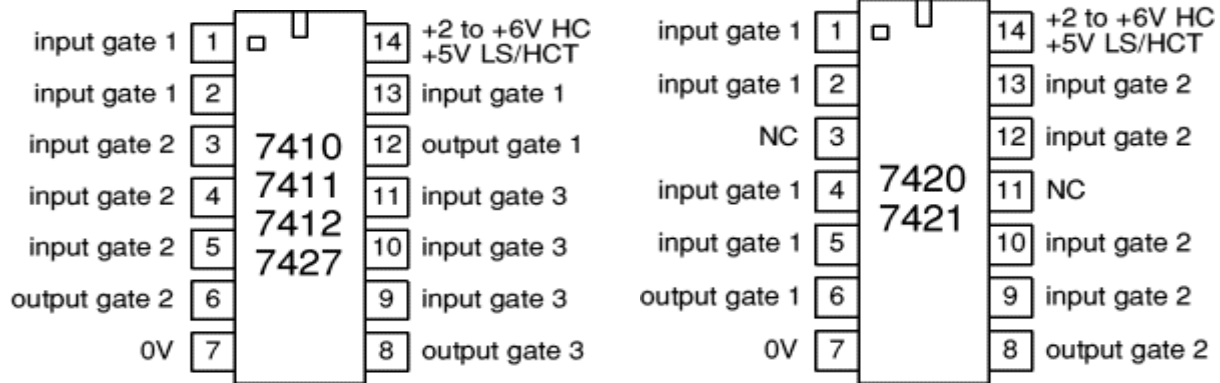

Theory:

The circuit below shows the solution. To the RS flip-flop we have added two new connections from the Q and Q' outputs back to the original input gates. Remember that a NAND gate may have any number of inputs, so this causes no trouble. To show that we have done this, we change the designations of the logic inputs and of the flip-flop itself. The inputs are now designated J (instead of S) and K (instead of R). The entire circuit is known as a *JK flip-flop*.

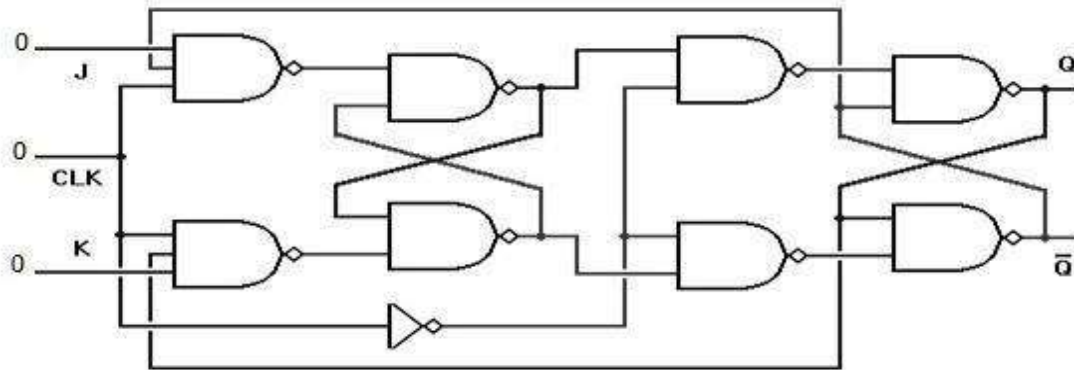

In most ways, the JK flip-flop behaves just like the RS flip-flop. The Q and Q' outputs will only change state on the falling edge of the CLK signal, and the J and K inputs will control the future output state pretty much as before. However, there are some important differences.

Since one of the two logic inputs is always disabled according to the output state of the overall flip-flop, the master latch cannot change state back and forth while the CLK input is at logic 1. Instead, the enabled input can change the state of the master latch *once*, after which this latch will not change again. This was not true of the RS flip-flop.

If both the J and K inputs are held at logic 1 and the CLK signal continues to change, the Q and Q' outputs will simply change state with each falling edge of the CLK signal. (The master latch circuit

will change state with each *rising* edge of CLK.) We can use this characteristic to advantage in a number of ways. A flip-flop built specifically to operate this way is typically designated as a *T* (for *Toggle*) flip-flop. The lone T input is in fact the CLK input for other types of flip-flops.





The JK flip-flop *must* be edge triggered in this manner. Any level-triggered JK latch circuit will oscillate rapidly if all three inputs are held at logic 1. This is not very useful. For the same reason, the T flip-flop must also be edge triggered. For both types, this is the only way to ensure that the flip-flop will change state only once on any given clock pulse. Because the behavior of the JK flip-flop is completely predictable under all conditions, this is the preferred type of flip-flop for most logic circuit designs. The RS flip-flop is only used in applications where it can be guaranteed that both R and S cannot be logic 1 at the same time.

At the same time, there are some additional useful configurations of both latches and flip-flops. In the next pages, we will look first at the major configurations and note their properties. Then we will see how multiple flip-flops or latches can be combined to perform useful functions and operations.

Master Slave Flip Flop: The control inputs to a clocked flip flop will be making a transition at approximately the same times as triggering edge of the clock input occurs. This can lead to unpredictable triggering.

A JK master flip flop is positive edge triggered, where as slave is negative edge triggered. Therefore master first responds to J and K inputs and then slave. If J=0 and K=1, master resets on arrival of positive clock edge. High output of the master drives the K input of the slave. For the trailing edge of the clock pulse the slave is forced to reset. If both the inputs are high, it changes the state or toggles on the arrival of the positive clock edge and the slave toggles on the negative clock edge. The slave does exactly what the master does.

Function Table:

Clk	J	K	Q	--- Q	comment
	0	0	Q ₀	---- Q ₀	No change
	0	1	0	1	Reset
	1	0	1	0	Set
	1	1	Q ₀	Q ₀	toggle

Circuit Diagram:

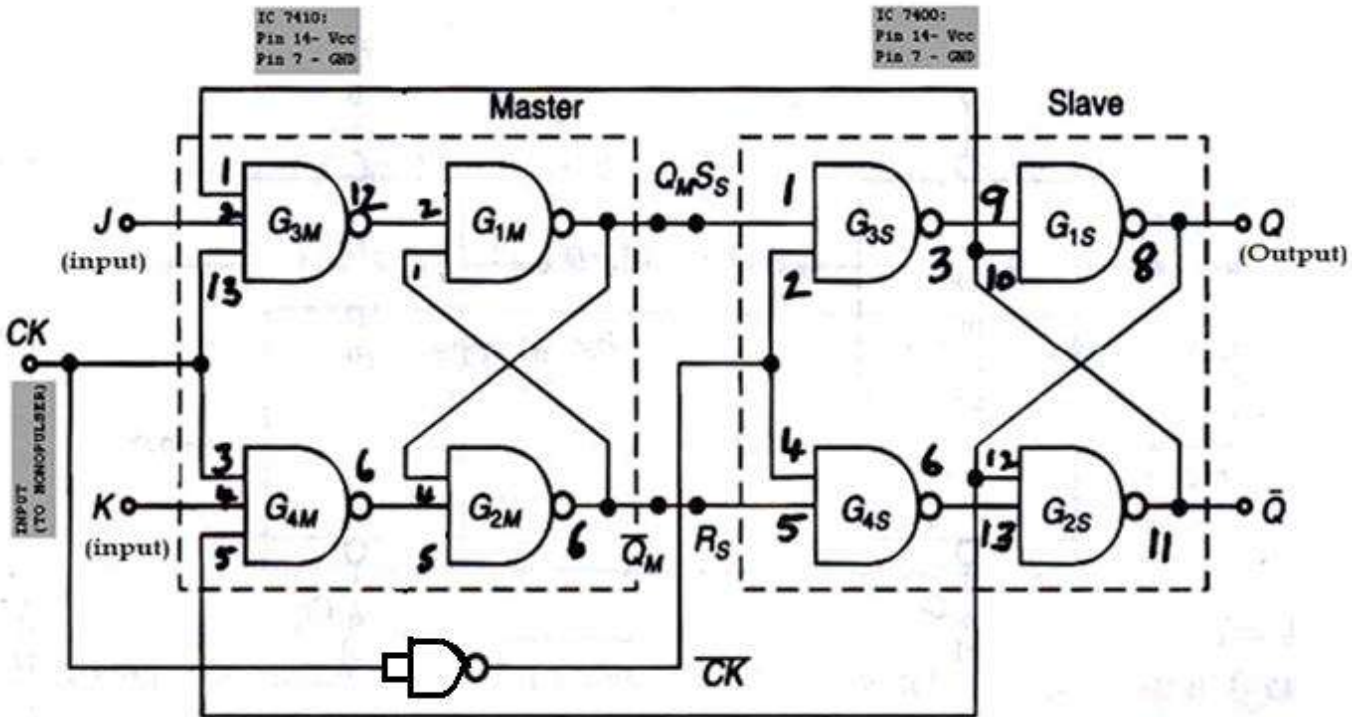

Procedure:

- Verify all components and patch chords whether they are in good condition are not.
- Make connection as shown in the circuit diagram.
- Give supply to the trainer kit.
- Verify the output with truth table.

Result:

Truth Table is verified

Simulation: VHDL code for JK master slave Flipflop

```
library IEEE;
use IEEE.STD_LOGIC_1164.ALL;
entity jkflip is
Port ( J, K, clk : in std_logic;
Q : buffer std_logic);
end jkflip;
architecture Behavioral of jkflip is
begin
process(clk)
begin
if rising_edge(clk) then
Q<= ((J and (not Q)) or ((not K) and Q));
end if;
end process;
end Behavioral;
```

Waveform:

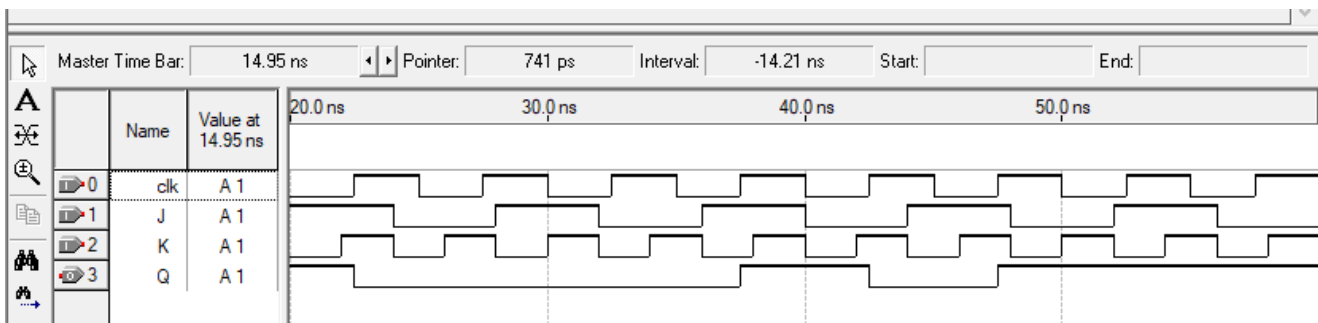

Viva Voce Questions	Blooms Taxonomy Level
1. Differentiate between combinational and sequential circuits.	1. L2
Give examples	2. L2
2. Give the applications of combinational and sequential circuits	3. L2
3. Define flip flop	4. L2
4. What is an excitation table?	5. L2
5. What is race around condition?	6. L3
6. How do you eliminate race around condition?	7. L2
7. Illustrate the Advantages of JK Master slave flip flop	

7. Design and implement code converter

I) Binary to Gray II) Gray to Binary Code using basic gates.

BINARY TO GRAY CONVERTER:

Decimal Number	4 bit Binary Number ABCD	4 bit Gray Code G ₄ G ₃ G ₂ G ₁
0	0000	0000
1	0001	0001
2	0010	0011
3	0011	0010
4	0100	0110
5	0101	0111
6	0110	0101
7	0111	0100
8	1000	1100
9	1001	1101
10	1010	1111
11	1011	1110
12	1100	1010
13	1101	1011
14	1110	1001
15	1111	1000

The logical circuit which converts binary code to equivalent gray code is known as binary to gray code converter. The gray code is a non weighted code. The successive gray code differs in one bit position only that means it is a unit distance code. It is also referred as cyclic code. It is not suitable for arithmetic operations. It is the most popular of the unit distance codes. It is also a reflective code. An n bit Gray code can be obtained by reflecting an n-1 bit code about an axis after 2ⁿ⁻¹ rows, and putting the MSB of 0 above the axis and the MSB of 1 below the axis. Reflection of Gray codes is shown below. The 4 bits binary to gray code conversion table is given below,

That means, in 4 bit gray code, (4-1) or 3 bit code is reflected against the axis drawn after (2⁴⁻¹)th or 8th row. The bits of 4 bit gray code are considered as G₄,G₃,G₂,G₁. Now from conversion table,

$$G_4 = \sum m (8, 9, 10, 11, 12, 13, 14, 15)$$

$$G_3 = \sum m (4, 5, 6, 7, 8, 9, 10, 11)$$

$$G_2 = \sum m (2, 3, 4, 5, 10, 11, 12, 13)$$

$$G_1 = \sum m (1, 2, 5, 6, 9, 10, 13, 14)$$

From above SOPs, let us draw K maps for G₄, G₃, G₂ and G₁.

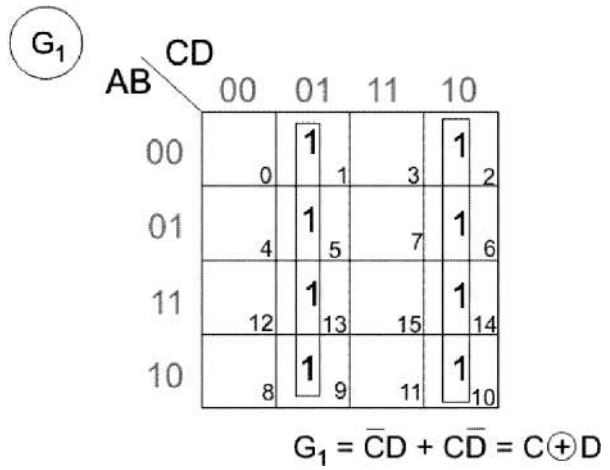
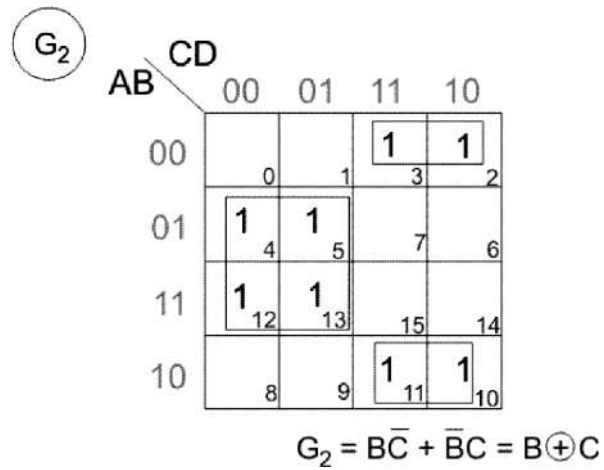
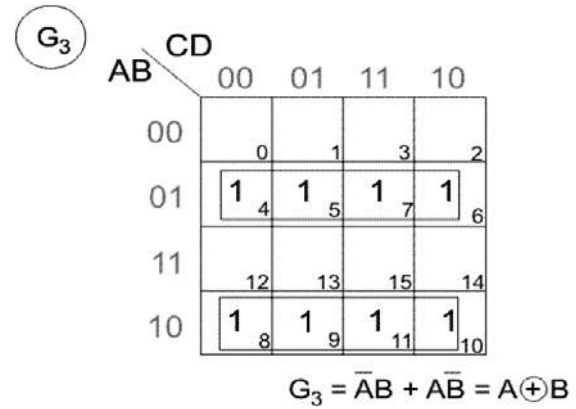
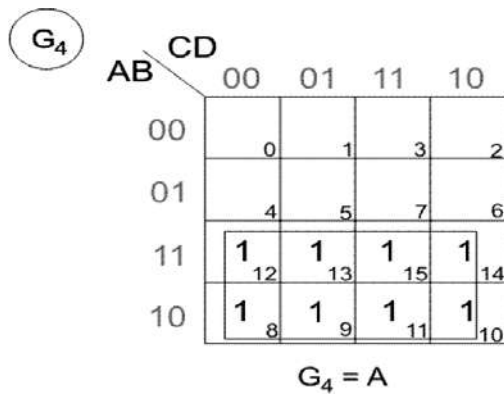

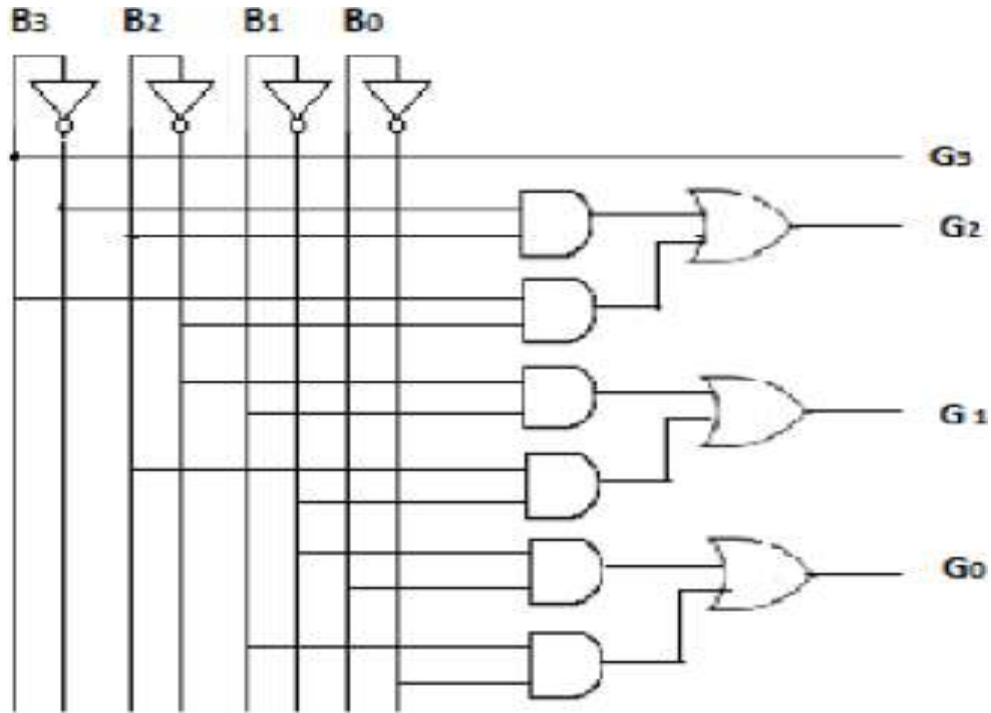

Fig : Binary to Gray Code converter

GREY TO BINARY CODE CONVERTER:

In gray to binary code converter, input is a multiplies gray code and output is its equivalent binary code. Let us consider a 4 bit gray to binary code converter. To design a 4 bit gray to binary code converter, we first have to draw a conversion table.

4 bit Gray Code				4 bit Binary Code			
A	B	C	D	B ₄	B ₃	B ₂	B ₁
0	0	0	0	0	0	0	0
0	0	0	1	0	0	0	1
0	0	1	1	0	0	1	0
0	0	1	0	0	0	1	1
0	1	1	0	0	1	0	0
0	1	1	1	0	1	0	1
0	1	0	1	0	1	1	0
0	1	0	0	0	1	1	1
1	1	0	0	1	0	0	0
1	1	0	1	1	0	0	1
1	1	1	1	1	0	1	0
1	1	1	0	1	0	1	1
1	0	1	0	1	1	0	0
1	0	1	1	1	1	0	1
1	0	0	1	1	1	1	0
1	0	0	0	1	1	1	1

B₄

		CD			
AB		00	01	11	10
00		0	1	3	2
01		4	5	7	6
11		1 ₁₂	1 ₁₃	1 ₁₅	1 ₁₄
10		1 ₈	1 ₉	1 ₁₁	1 ₁₀

$B_4 = A$

B₃

		CD			
AB		00	01	11	10
00		0	1	3	2
01		1 ₄	1 ₅	1 ₇	1 ₆
11		12	13	15	14
10		1 ₈	1 ₉	1 ₁₁	1 ₁₀

$B_3 = \bar{A}B + A\bar{B} = A \oplus B$

B₂

		CD			
AB		00	01	11	10
00		0	1	1 ₃	1 ₂
01		1 ₄	1 ₅	7	6
11		12	13	1 ₁₅	1 ₁₄
10		1 ₈	1 ₉	11	10

$$\begin{aligned}
 B_2 &= \bar{A}B\bar{C} + A\bar{B}\bar{C} + \bar{A}\bar{B}C + ABC \\
 &= A(\bar{B}\bar{C} + BC) + \bar{A}(\bar{B}\bar{C} + \bar{B}C) \\
 &= A(\overline{B\bar{C}} + \overline{\bar{B}C}) + \bar{A}(\overline{B\bar{C}} + \overline{\bar{B}C}) \\
 &= A(\bar{B} \oplus \bar{C}) + \bar{A}(\bar{B} \oplus \bar{C}) = A \oplus B \oplus C
 \end{aligned}$$

B₁

		CD			
AB		00	01	11	10
00		0	1	3	1 ₂
01		1 ₄	5	1 ₇	6
11		12	1 ₁₃	15	1 ₁₄
10		1 ₈	9	1 ₁₁	10

$$\begin{aligned}
 B_1 &= \bar{A}\bar{B}\bar{C}D + \bar{A}\bar{B}C\bar{D} + \bar{A}B\bar{C}\bar{D} + \bar{A}BCD + A\bar{B}\bar{C}D + ABC\bar{D} + A\bar{B}C\bar{D} \\
 &\quad + \bar{A}BCD = A \oplus B \oplus C \oplus D
 \end{aligned}$$

From above gray code we get,

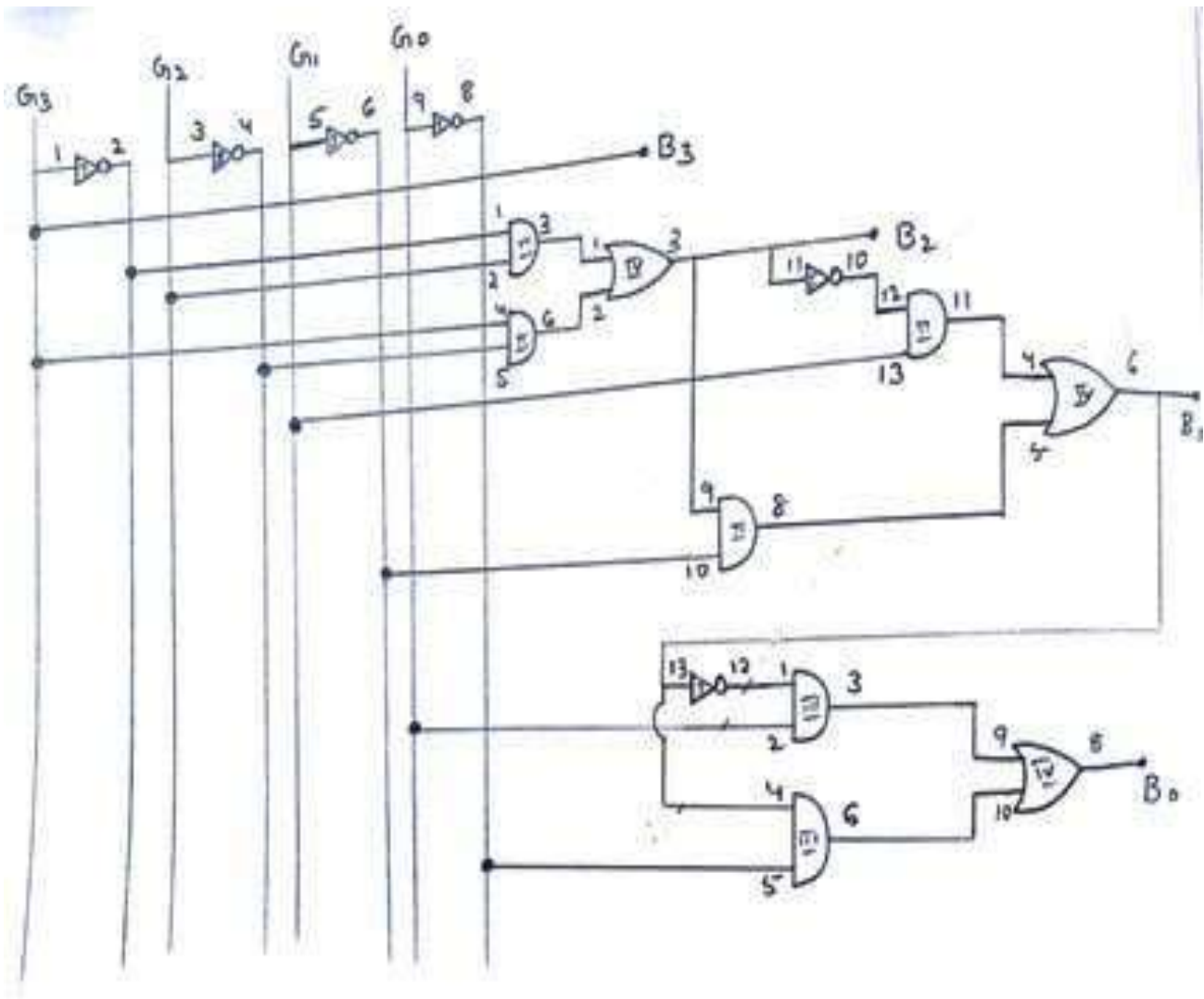

Fig : Gray to Binary Code converter

RESULT:

Truth Table is verified.

Viva Voce Questions	Blooms Taxonomy Level
1. What are code converters?	1. L3
2. What is the necessity of code conversions?	2. L2
3. What is gray code?	3. L2
4. Advantages of Realize the Boolean expressions for a Binary to gray code conversionb Gray to binary code conversion	4. L3
5. Advantages of Realize the Boolean expressions for a Binary to gray code conversionb Gray to binary code conversion	5. L3
6. What is excess 3 code	6. L2
7. Where do we apply conversion of a Binary to gray code conversionb Gray to binary code conversion	7. L3

Design and implement code converter using 3 bits

I) Binary to Gray II) Gray to Binary Code using basic gates.

BINARY TO GRAY CODE AND GRAY TO BINARY CODE CONVERTER:

Define and Implement code converter

A B C	G_1	G_2	G_3
0 0 0	0	0	0
0 0 1	0	0	1
0 1 0	0	1	1
0 1 1	0	1	0
1 0 0	1	1	0
1 0 1	1	1	1
1 1 0	1	0	1
1 1 1	1	0	0

A B C	B_1	B_2	B_3
0 0 0	0	0	0
0 0 1	0	0	1
0 1 0	0	1	1
0 1 1	0	1	0
1 0 0	1	1	1
1 0 1	1	1	0
1 1 0	1	0	1
1 1 1	1	0	0

The logical circuit which converts binary code to equivalent gray code is known as binary to gray code converter. The gray code is a non weighted code. The successive gray code differs in one bit position only that means it is a unit distance code. It is also referred as cyclic code. It is not suitable for arithmetic operations. It is the most popular of the unit distance codes. It is also a reflective code. An n bit Gray code can be obtained by reflecting an n-1 bit code about an axis after 2^{n-1} rows, and putting the MSB of 0 above the axis and the MSB of 1 below the axis. Reflection of Gray codes is shown below. The 3 bits binary to gray code conversion simplification using k-map is given below,

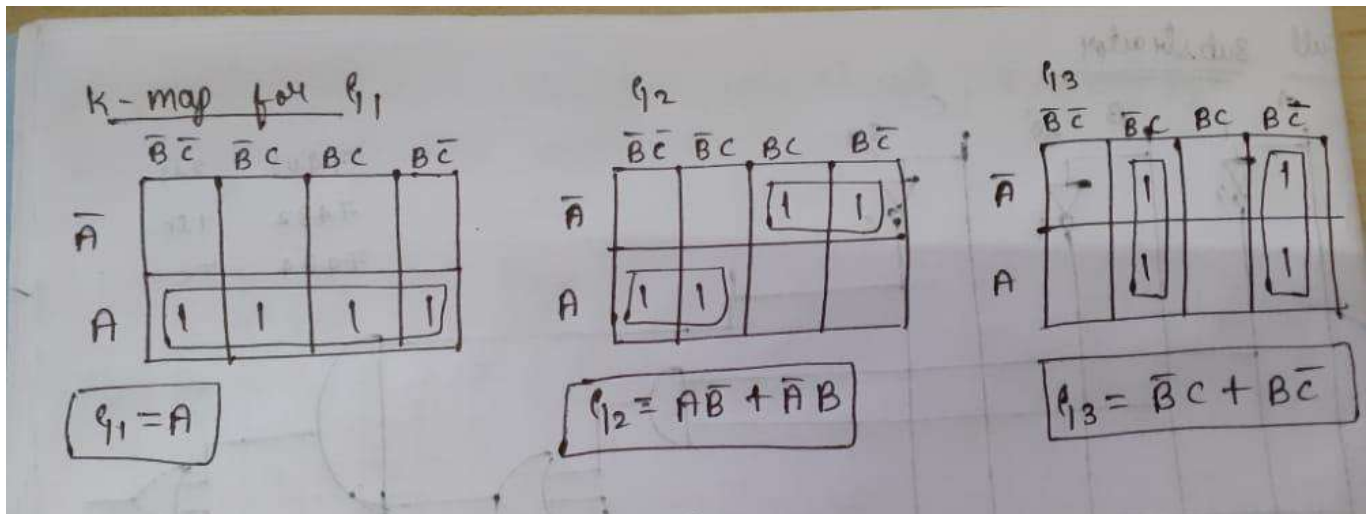

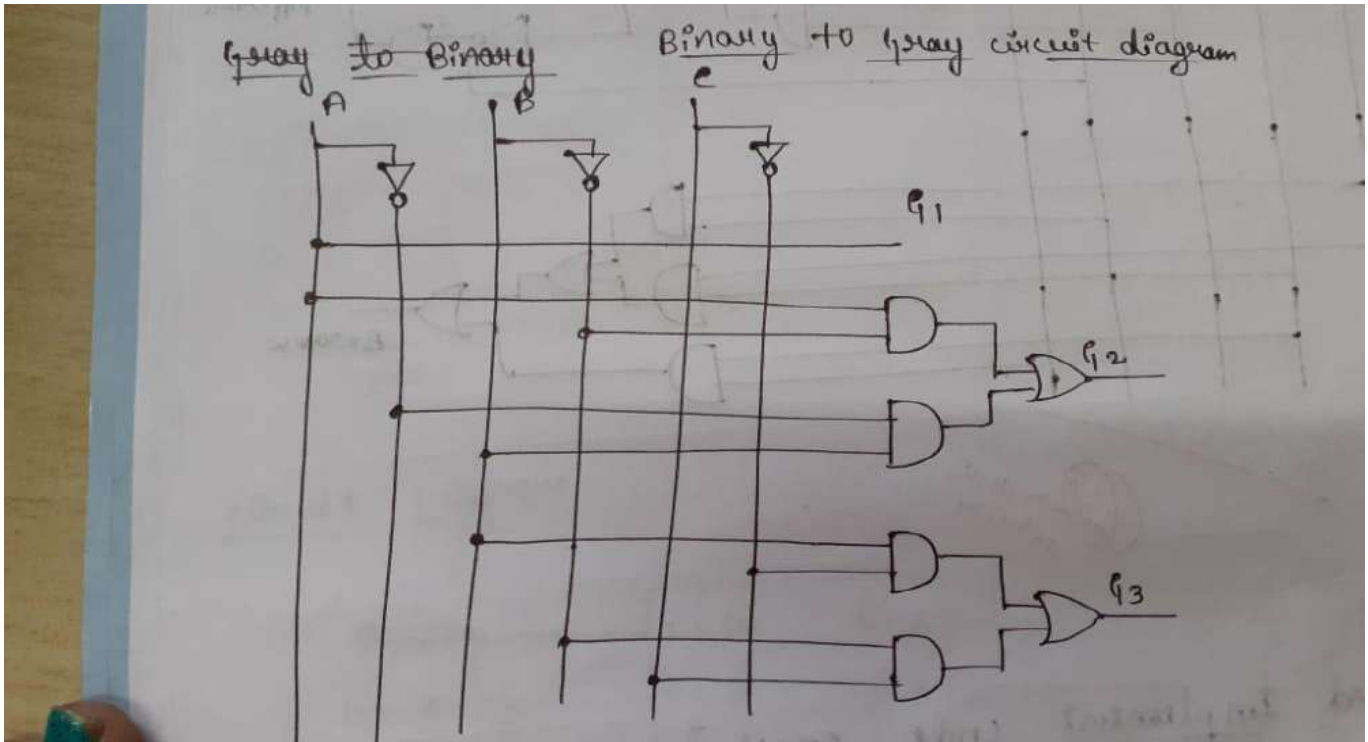

Fig : Circuit diagram for Binary to Gray Code converter

K-map for Gray to Binary conversion is given below, Refer Truth table given above

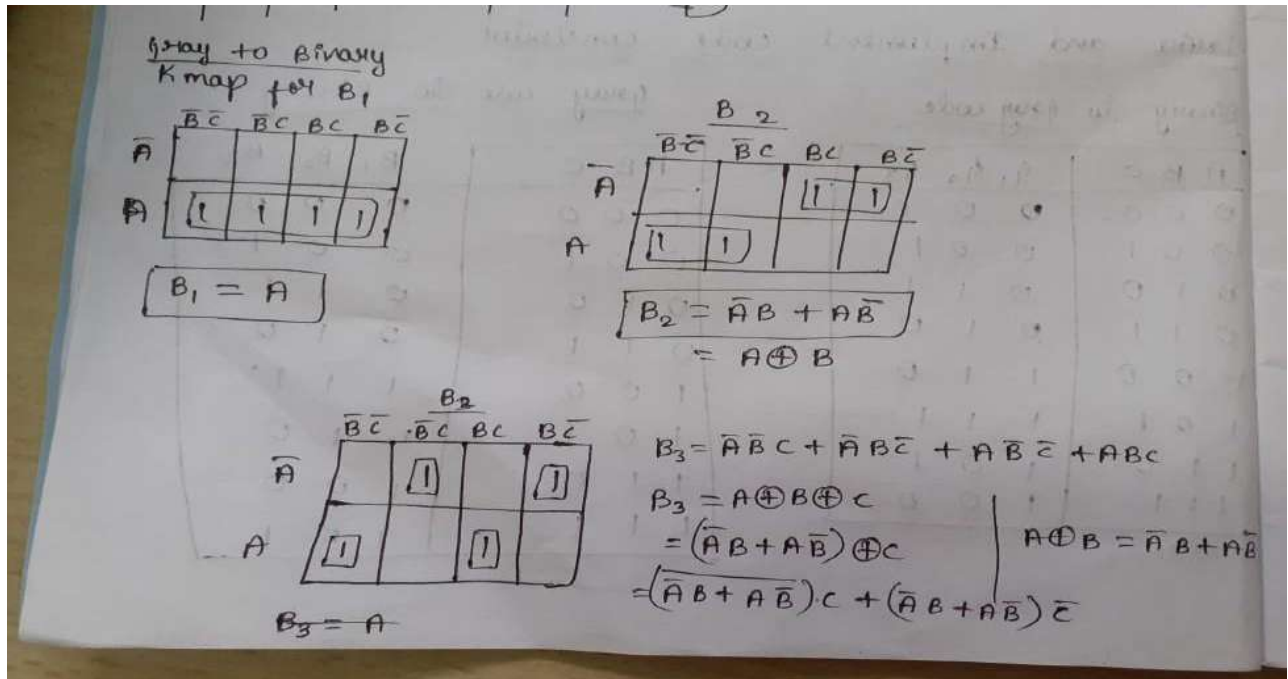
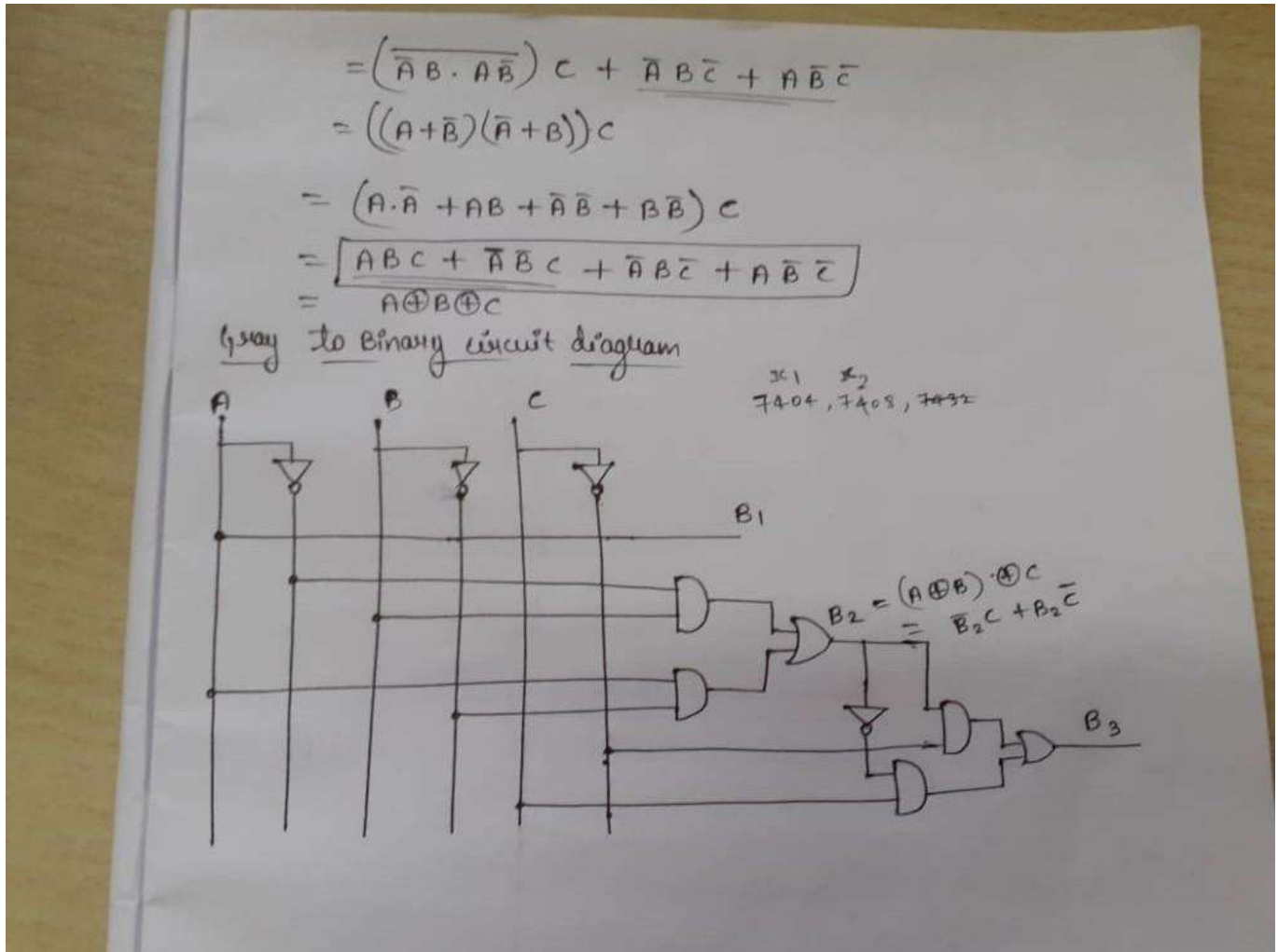

Fig: Circuit diagram for Gray to Binary Code converter



Viva Voce Questions	Blooms Taxonomy Level
1. What are code converters?	1. L3
2. What is the necessity of code conversions?	2. L2
3. What is gray code?	3. L2
4. Advantages of Realize the Boolean expressions for a Binary to gray code conversionb Gray to binary code conversion	4. L3
5. Advantages of Realize the Boolean expressions for a Binary to gray code conversionb Gray to binary code conversion	5. L3
6. What is excess 3 code	6. L2
7. Where do we apply conversion of a Binary to gray code conversionb Gray to binary code conversion	7. L3

8. Design and implement a mod n (n<8) synchronous up counter using JK Flip Flop ICs and demonstrate its working.

Components used: IC 74LS76, IC 74LS08, Patch chords, power chords, and Trainer kit.

Pin diagram of 7476

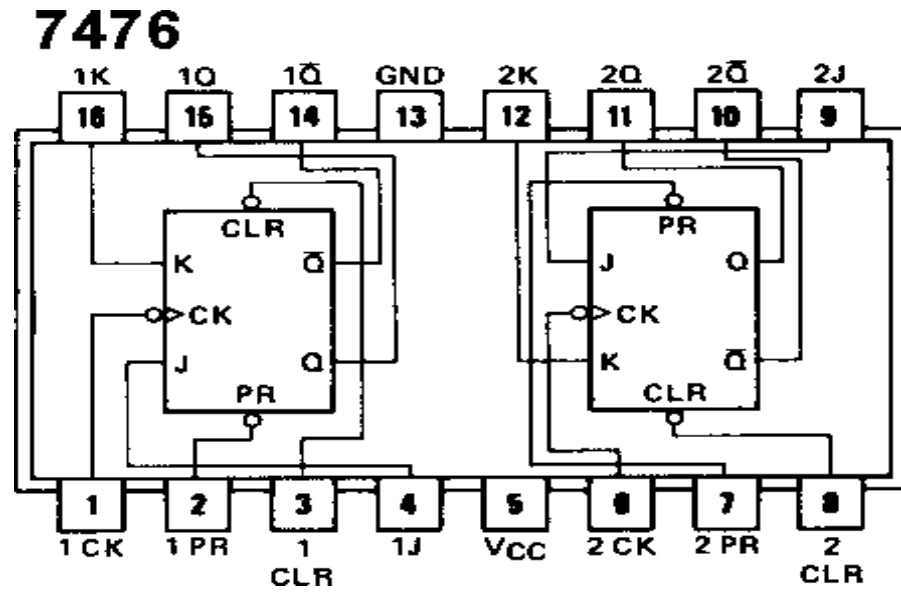

Function Table

Inputs					Outputs	
PR	CLR	CLK	J	K	Q	Q̄
L	H	X	X	X	H	L
H	L	X	X	X	L	H
L	L	X	X	X	H	H
H	H	⌋	L	L	Q ₀	Q̄ ₀
H	H	⌋	H	L	H	L
H	H	⌋	L	H	L	H
H	H	⌋	H	H	Toggle	

Q _n	Q _{n+1}	J	K
0	0	0	X
0	1	1	X
1	0	X	1
1	1	X	0

Theory:

The ripple counter requires a finite amount of time for each flip flop to change state. This problem can be solved by using a synchronous parallel counter where every flip flop is triggered in synchronism with the clock, and all the output which are scheduled to change do so simultaneously. The counter progresses counting upwards in a natural binary sequence from count 000 to count 100 advancing count with every negative clock transition and get back to 000 after this cycle.

Designing:

a) Transition Table: Mod 5 (0 – 4)

Present State Qc Qb Qa			Nert State Qc+1 Qb+1 Qa+1			Jc	Kc	Jb	Kb	Ja	Ka
0	0	0	0	0	1	0	x	0	x	1	x
0	0	1	0	1	0	0	x	1	x	x	1
0	1	0	0	1	1	0	x	x	0	1	x
0	1	1	1	0	0	1	x	x	1	x	1
1	0	0	0	0	0	x	1	0	x	0	x
Not used			So filled with don't			care		values			
1	0	1	x	x	x	x	x	x	x	x	x
1	1	0	x	x	x	x	x	x	x	x	x
1	1	1	x	x	x	x	x	x	x	x	x

b) K-map Simplification:

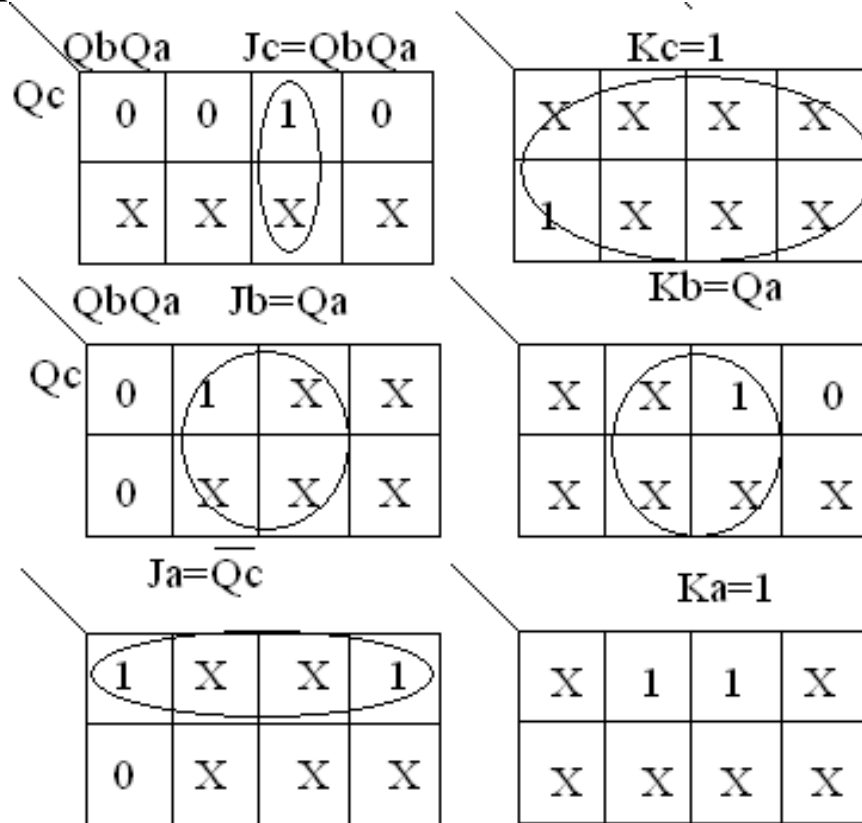

c) Diagram & implementation

Circuit Diagram:

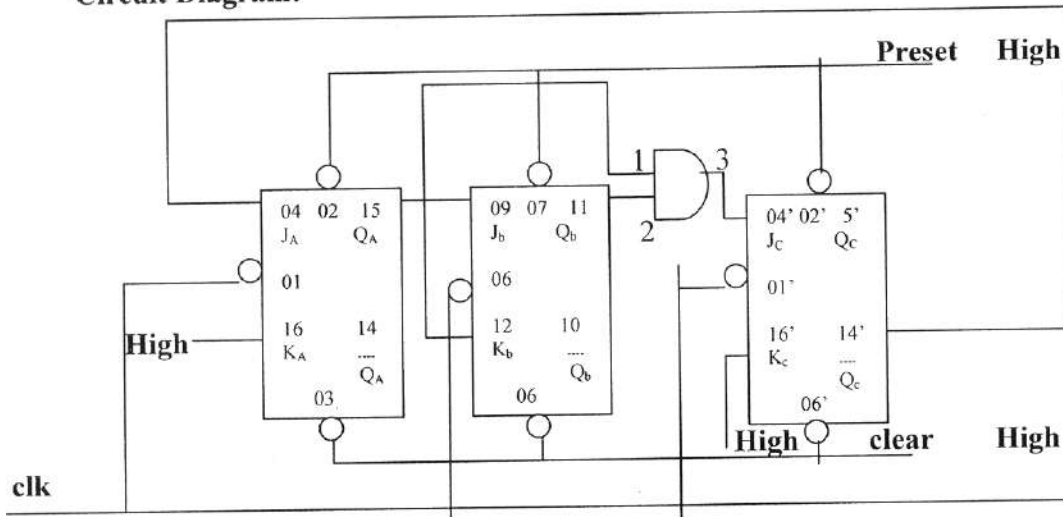

Procedure:

- (1) Verify all components and patch chords whether they are in good condition or not.
- (2) Make connection as shown in the circuit diagram.
- (3) Give supply to the trainer kit.
- (4) Provide input data to circuit via switches.
- (5) Verify truth table sequence and observe outputs.

Result:

Truth Table is verified

Viva Voce Questions	Blooms Taxonomy Level
1. What are counters? Give their applications.	1. L2
2. Compare synchronous and asynchronous counters	2. L2
3. What is modulus of a number?	3. L2
4. What is a shift register?	4. L2
5. List the applications of Counters	5. L2
6. What is frequency division	6. L2
7. Different approach for design of counter circuits	7. L2

9. Design and implement asynchronous counter using decade counter IC to count up from 0 to n (n≤9) and demonstrate on seven segment display (using IC-7447).

Components Required: ICs used: 7490,7447, 507

Pin Details of the ICs: PIN diagram of 7490,7447,FND 507

Description:

Asynchronous counter is a counter in which the clock signal is connected to the clock input of only first stage flip flop. The clock input of the second stage flip flop is triggered by the output of the first stage flip flop and so on. This introduces an inherent propagation delay time through a flip flop. A transition of input clock pulse and a transition of the output of a flip flop can never occur exactly at the same time. Therefore, the two flip flops are never simultaneously triggered, which results in asynchronous counter operation.

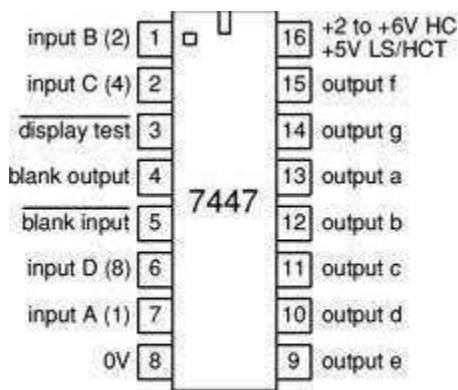

Pin diagram of 7447

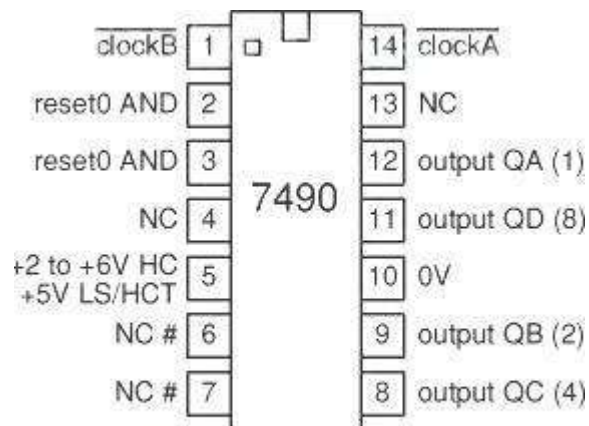

Pin diagram of 7490

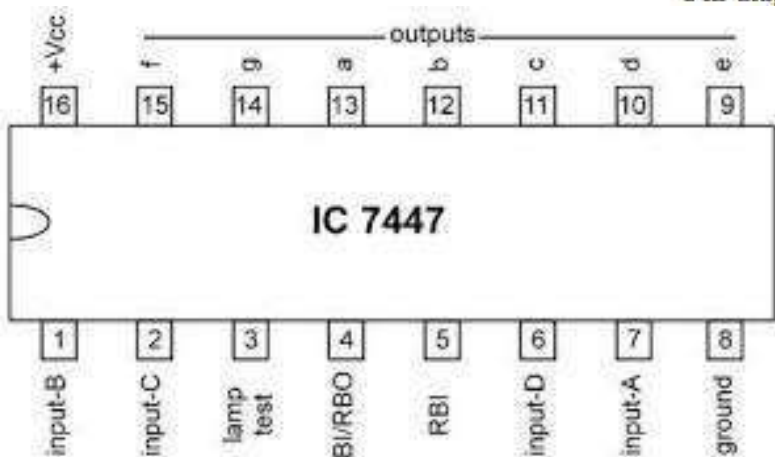

Pin configuration of IC 7447 and FND 507

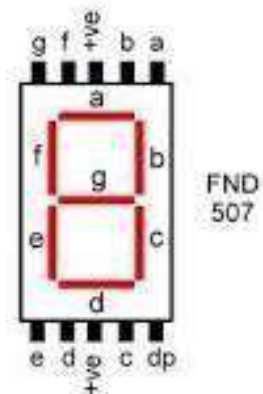

Function Table:

Clock	Q3	Q2	Q1	Q0
0	0	0	0	0
1	0	0	0	1
2	0	0	1	0
3	0	0	1	1
4	0	1	0	0
5	0	1	0	1
6	0	1	1	0
7	0	1	1	1
8	1	0	0	0
9	1	0	0	1

Result:

mod $n \leq 9$ counter implemented using the decade counter IC

Viva Voce Questions	Blooms Taxonomy Level
1. What are decade counters? Give their applications.	1. L2
2. Compare synchronous and asynchronous counters	2. L2
3. What is FND display?	3. L2
4. What is a decoder?	4. L2
5. Illustrate the design of decoder circuit	5. L2

Analog Electronics Software Experiments with PSpICE

The steps to simulation

1. Create a simulation project
2. Draw schematic to simulate
3. Establish a simulation profile
4. Set up simulation type
5. Simulate circuit
6. Analyze results in Probe

General Procedure to use for all simulation experiments:

Start → Programs → Orcad family lite edition → Caputre lite edition → File

- 1) Select new & blank project, select analog & mixed mode for new simulation (use open project for already existing project).
- 2) Layout appears select components from parts & place at required position on layout, connect components using wire, apply voltage marker at i/p & o/p to see wave forms.
- 3) If components are not available it is required to add by using add library present in window.
- 4) From menu bar select PSpice, new simulation profile to Set simulation profile like
Select Analysis type: Time domain (or) AC sweep as per experiment.
Set Start value, Step size & End valu then Save settings.
- 5) Run simulation observe & note the output waveform.
- 6) Use Edit profile for any changes required in profile.
- 7) Simulation can be done for different values of component & supply.

Digital Electronics Software Experiments with Xilinx

Software package used for Digital experiment Xilinx 6.1 with Modelsim 9.2 , It is one of most popular software tool used to synthesize VHDL code. This tool Includes many steps. To make user feel comfortable with the tool the steps are given below:-

These steps are common to all Digital experiment for simulation & synthesis part.

- Double click on Project navigator. (Assumed icon is present on desktop).
- Select **NEW PROJECT** in **FILE MENU**.
Enter following details as per your convenience
Project name : new
Project location : C:\create your folder
Top level module : HDL
- In **NEW PROJECT** dropdown Dialog box, Choose your appropriate device specification.
Example is given below:
Device family : Spartan2
Device : xc2s200
Package : PQ208
TOP Level Module : HDL
Synthesis Tool : XST
Simulation : Modelsim / others
Generate sim lang : VHDL
- In source window right click on specification, select new source
Enter the following details
Entity: sample
Architecture : **Behavioral**
Enter the input and output port and modes.
This will create **sample.VHD** source file. Click Next and finish the initial Project preparation.
- Double click on synthesis. If error occurs edit and correct VHDL code.
- Top level module appears, again select new source & set test bench waveform.
- Double click on Lunch modelsim (or any equivalent simulator if you are using) for functional simulation of your design.

RUBRICS

1. FOR 40 MARKS (2018 NEW SCHEME)

Sl.No.	DESCRIPTION	MARKS
1.	<u>CONTINUOUS EVALUATION</u> a. Observation write up & punctuality b. Conduction of experiment and output c. Viva voce d. Record write up	<u>25</u> 5.0 10.0 5.0 5.0
2.	INTERNAL TEST	15.0

Sample Viva Questions

6. Why operational amplifier is called by its name?
7. Explain the advantages of OPAMP over transistor amplifiers.
8. List the OPAMP ideal characteristics.
9. Give the symbol of OPAMP
10. Explain the various applications of OPAMP
11. Define UTP and LTP
12. Mention the applications of schmitt trigger
13. What is a square wave generator/ Regenerative comparator?
14. Give the hysteresis curve of a schmitt trigger
15. What is a bipolar and unipolar devices? Give examples
16. Define resolution
17. Explain the need of D/A and A/D converters.
18. List the different types of A/D and D/ A converters
19. What is a multivibrators?
20. What is a bistable multivibrators?
21. Give the applications of monostable and astable multivibrators
22. Explain the working of 555 timer as astable and monostable multivibrator
23. Why astable multivibrator is called as free running multivibrato
24. Define duty cycle.
25. List the applications of 555 timer
26. Explain 555 timer as astable multivibrator to generate a rectangular wave of duty cycle of less than 0.5
27. Define a logic gate.
28. What are basic gates?
29. Why NAND and NOR gates are called as universal gates?
30. State De morgans theorem
31. Give examples for SOP and POS
32. Explain how transistor can be used as NOT gate
33. Realize logic gates using NAND and NOR gates only
34. List the applications of EX-OR and EX-NOR gates
35. What is a half adder?
36. What is a full adder?

37. Differentiate between combinational and sequential circuits. Give examples
38. Give the applications of combinational and sequential circuits
39. Define flip flop
40. What is an excitation table?
41. What is race around condition?
42. How do you eliminate race around condition?
43. What is minterm and max term?
44. Define multiplexer/ data selector
45. What is a demultiplexer?
46. Give the applications of mux and demux
47. What is an encoder and decoder?
48. Compare mux and encoder

49. Compare demux and decoder
50. What is a priority encoder?
51. What are counters? Give their applications.
52. Compare synchronous and asynchronous counters
53. What is modulus of a number?
54. What is a shift register?
55. What does LS stand for, in 74LS00?
56. What is positive logic and negative logic?
57. What are code converters?
58. What is the necessity of code conversions?
59. What is gray code?
60. Realize the Boolean expressions for
 - a Binary to gray code conversion
 - b Gray to binary code conversion

Note:

All the above questions are the most commonly asked and the depth of it may vary based on the answers which you give during the viva voice procedure.

All the very best!