



|| Jai Sri Gurudev ||
Sri Adichunchanagiri Shikshana Trust (R)

SJC Institute of Technology

Chickballapur - 562 101, Karnataka

VTU Affiliated, AICTE Approved, Accredited by NAAC & NBA (CSE, ECE, ME), Gold Rated by QS-I Quage



Department of Civil Engineering



Estd : 1986

Laboratory Manual

Computer Aided Building Planning & Drawing 18CVL37



Prepared by

Mr. Ravi Kiran B
Assistant Professor

Approved by

Dr. G Narayana
Professor and Head

S J C INSTITUTE OF TECHNOLOGY

CHICKBALLAPUR – 562101

**DEPARTMENT
OF
CIVIL ENGINEERING**

**Computer Aided Building Planning and Drawing
Manual**

Subject Code: (18CVL37)

FOREWORD

I am extremely happy to place before all readers this manual prepared by the Department of Civil Engineering SJCIT Chickballapur. The manual is prepared taking into view the new VTU syllabus for III Semester B.E. (Civil). The manual gives a clear insight into the relevance of each experiments, calculations needed, necessary formulae, Graphs to be plotted and Inferences that could be drawn are clearly mentioned. It is hoped that this manual will clear doubts in minds of students about the experiments in Computer Aided Building Planning & Drawing (18CVL37).

I wish to express my heartfelt gratefulness to his Holiness Paramapoojya Jagadguru Padmabhushan Bhairavaikya Sri. Sri. Sri. Dr. Balagangadharanatha Maha Swamiji and to his Holiness Jagadguru Sri. Sri. Sri. Dr. Nirmalanandhanatha Maha Swamiji Pontiff, Adichunchanagiri Shikshna Trust®.

I would also like to thank our beloved principal Dr. G T Raju for his continuous support and encouragement.

I thank Mr. Ravi Kiran B, Assistant professor in the department of civil engineering, having prepared this manual.

Dr. G NARAYANA

Professor and Head

Department of Civil Engineering

|| Jai Sri Gurudev ||



Sri Adichunchanagiri Shikshana Trust ®

SJC INSTITUTE OF TECHNOLOGY

Chickballapur – 562 101



DEPARTMENT OF CIVIL ENGINEERING



LABORATORY CERTIFICATE

This is to certify that the Mr. / Ms.

bearing USN Sem..... Branch.....

has satisfactorily completed the practical experiments of.....

..... Laboratory prescribed by the

Visvesvaraya Technological University, Belgavi for the year

**Signature of the Teacher
(In charge of the Batch)**

Head of the Department

|| Jai Sri Gurudev ||
SJC institute of Technology, Chickballapur
Department of Civil Engineering

Vision

Building Competent Civil Engineers with a Societal Perspective.

Mission

M1: Providing Conducive Learning Environment focusing on Planning, Analysis, Design and Detailing of Sustainable Infrastructure

M2: Imparting Training, Research and Consultancy in Collaboration with Research Institutes and Industries

M3: Equipping Students with Employability Skills through Internships, Industrial Interactions and Field Visits

M4: Exploring Comprehensive Environmental Aware Solutions for Various Fields of Civil Engineering with Multidisciplinary Approach

M5: Imbibing Lifelong Learning, Professionalism and Ethics among Civil Engineering Students

Program Educational Objectives (PEO's)

PEO1: Graduates will have successful career in civil engineering industries, public sector or as Entrepreneurs.

PEO2: Graduates will pursue higher education in leading institutes/engage in continuing education to be competitive in the organization.

PEO3: Graduates will design cost effective and sustainable civil engineering structures conforming to standards.

Program Specific Outcomes (PSO's)

After Successful completion of B.E program in Civil Engineering, the students will be able to:

PSO1: Apply Civil engineering knowledge in analysis, design, laboratory investigation & Construction aspects.

PSO2: Solve problems in various fields of civil engineering with appropriate construction materials and technology.

Course Learning Objectives: Provide students with a basic understanding

1. Achieve skill sets to prepare computer aided engineering drawings
2. Understand the details of construction of different building elements.
3. Visualize the completed form of the building and the intricacies of construction based on the engineering drawings.

Course Outcomes: After a successful completion of the course, the student will be able to:

1. Make use of the software tools and commands.
2. Choose scale factor and drawing standards.
3. Draw the various building components and also other structural Components.
4. Develop the working Drawings and recommend the details as per local bye laws.

Program Outcomes (POs)

- **Engineering knowledge:** Apply the knowledge of mathematics, science, engineering fundamentals, and an engineering specialization to the solution of complex engineering problems.
- **Problem analysis:** Identify, formulate, research literature, and analyze complex engineering problems reaching substantiated conclusions using first principles of mathematics, natural sciences, and engineering sciences.
- **Design/development of solutions:** Design solutions for complex engineering problems and design system components or processes that meet the specified needs with appropriate consideration for the public health and safety, and the cultural, societal, and environmental considerations.
- **Conduct investigations of complex problems:** Use research-based knowledge and research methods including design of experiments, analysis and interpretation of data, and synthesis of the information to provide valid conclusions
- **Modern tool usage:** Create, select, and apply appropriate techniques, resources, and modern engineering and IT tools including prediction and modeling to complex engineering activities with an understanding of the limitations.
- **The engineer and society:** Apply reasoning informed by the contextual knowledge to assess societal, health, safety, legal and cultural issues and the consequent responsibilities relevant to the professional engineering practice.
- **Environment and sustainability:** Understand the impact of the professional engineering solutions in societal and environmental contexts, and demonstrate the knowledge of, and need for sustainable development.
- **Ethics:** Apply ethical principles and commit to professional ethics and responsibilities and norms of the engineering practice.
- **Individual and team work:** Function effectively as an individual, and as a member or leader in diverse teams, and in multidisciplinary settings.
- **Communication:** Communicate effectively on complex engineering activities with the engineering community and with society at large, such as, being able to comprehend and write effective reports and design documentation, make effective presentations, and give and receive clear instructions.
- **Project management and finance:** Demonstrate knowledge and understanding of the engineering and management principles and apply these to one's own work, as a member and leader in a team, to manage projects and in multidisciplinary environments.
- **Life-long learning:** Recognize the need for, and have the preparation and ability to engage in independent and life-long learning in the broadest context of technological change.

MODULE 1

Drawing basics

Introduction

The art of representing technical structures with the aid of drawing instruments on paper is known as working drawing. A working drawing if properly drawn can convey the details such as shape, size, materials used, location, placing and planning of different services; in short it conveys the whole form of the structure, on the paper before the materialization of the structure. So these drawings are most prior thing in any civil engineering projects.

The building drawing office practices followed are based on certain basic principles as laid down by ISI. These principles are called “Code of Practice” and the guidelines for engineering drawing are as per IS 962 – “Code of practice for Architectural and Building Drawings” and IS 10711. They include size of papers, layout of drawings, conventional representations, sizes of letters and numerals on drawings, graphic symbols and abbreviations. Following paragraphs deal with the same.

An engineering drawing traditionally is prepared using drawing instruments. But the accuracy of these drawing is dependent on the individual skill of the person drawing them. The modifications and repetition work of these drawings are cumbersome and time consuming. Hence the popular alternative for manual preparation of engineering drawing is the computer aided design and drafting system. One such most widely used drafting tool is AutoCAD.

Size of drawings

Drawing sheets are cut from rolls and are made into different sizes so that each size can be worked upon. The table below gives the standard size of drawing sheets.

Sl. No.	Size Designation	Trimmed size of the drawing sheet (mm)
1	A0	841 x 1189
2	A1	584 x 841
3	A2	420 x 594
4	A3	297 x 420
5	A4	210 x 297

Layout and Title block

Border lines should be drawn all-round the drawing sheet leaving a margin of 25mm or 30mm on left hand side and 10mm on all other sides. Title block is drawn at the right bottom corner of the sheet and remaining space is utilized for drawing.

A title block normally carries the following information;

- (i) Title of the drawing
- (ii) Name of organization
- (iii) Drawing number with revision number
- (iv) Scale
- (v) Date of the drawing
- (vi) Signature of the concerned authorities.

Scales

Drawings drawn to the scale enable dimensions to be “read-off” from the drawing. When the drawing is made to the same scale as that of actual object, it is called full scale (1:1). However, the building drawings are too large to be drawn to full size. Therefore, there must be reduced scales to fit the normal drawing sheets. Thus the main function of scale is to enable the designer to draw a building to a convenient size to enable the builder to think in relation to the actual size of the structures.

Sl. No. Drawing Scale

- 1 Large plot plans 1:200
- 2 Small plot plans 1:100
- 3 Floor plan 1:50
- 4 Detailed drawing 1:20, 1:10, 1:5

Line work

All lines should be dense, clean and black and black to produce good prints. For details reference shall be made to IS 10714:1983.

Lettering and Dimensioning

The writing of details, references and naming of different views are done with the letters of uniform sizes.

Sl. No. Purpose Size of the letters

Height in mm

- 1 Main title and drawing number 6, 8, 10 & 12
- 2 Sub-titles and heading 3, 4, 5 & 6
- 3 Notes such as legends, schedules, materials and dimensions 2, 3, 4 & 5

Conventional signs and symbols

Conventional signs are used on building drawings to represent various building materials and Conventional symbols are the short notations which are used to represent the actual object in building drawings. These are also called as civil engineering symbols which give approximate shape of the object.

The conventional symbols represent the object at a particular location of sanitary fittings such as towel rail, water closet, sink, wash basin, shower and electrical fittings like switch, ceiling fan, exhaust fan and even furniture as dining table, chairs, cloths cabinet, dressing table, T.V., etc. These are not drawn according to the scale but drawn proportionately. The Bureau of Indian Standards has recommended various types of conventional signs and symbols to fulfil the following objectives;

- _ To save time, labour, material and space on drawing sheet.
- _ To avoid confusion and misunderstanding.
- _ To achieve quick identifications of details.
- _ To increase the speed in preparation of drawings.
- _ To save time in reading and understanding the drawing.
- _ To avoid confusion in interpretation of details by the site supervisors, etc.

AutoCAD - essential

About AutoCAD

AutoCAD is most popular computer aided design and drafting software application from Autodesk, a leading US based company. Apart from AutoCAD, Autodesk has a spectrum of products for various fields such as Mechanical, AEC, GIS, R to V.

Launching AutoCAD is very simple: Just double click on the short cut icon of AutoCAD program or start the application by clicking,

Start > Program > Autodesk > AutoCAD > AutoCAD

After few moments, you could see the Graphical User Interface (GUI) of AutoCAD. The AutoCAD environment looks as in figure below. The AutoCAD GUI is very user friendly and comprehensive consisting of various Menus and tool bars. The arrangement of the Menu bar and Tool bars can be customized.

Communicating with AutoCAD

AutoCAD is a servant, it does everything you tell it and no more. You can communicate with it using commands in the menu, screen menu, command line and buttons on the toolbars.

Command: A command is a single word instruction from the user to perform the required task. When you invoke a command, AutoCAD responds by presenting messages in the command prompt area or by displaying dialogue box. The messages in the command prompt are often tell you what to do next or they offer lot of options pertaining to the command. The commands can also be called by one or two letter short cut keys.

The Menu

The menus are available on the menu bar offer a quicker way to access the commands and functions that are the heart of AutoCAD. The menu options issue a command that requires keyboard or drawing inputs. As you select the commands and options, AutoCAD flashes a single line help in the status bar.

1. NEW

Menu: File

Command line: new

It creates a new drawing file. The behaviour of the NEW command is determined by the startup setting on the System tab of the Options dialogue box.

Show the Start-up dialogue box: NEW displays the *Create New Drawing* dialogue box. Do Not Show the Start-up dialogue box: NEW displays the *Select Template* dialogue box. Create New Drawing dialogue box: Defines the settings for a new drawing. There are three main methods to create a new drawing.

Start from Scratch: Starts an empty drawing using default imperial or metric settings. Use of Template: Starts a new drawing file based on a drawing template file. Template drawings store all the settings for a drawing and may also include predefined layers, dimension styles and views. They are normally kept in a template directory and template drawings are distinguished from other drawing files by .dwt file extension. *Select a Template* lists all DWT files that currently exist in the drawing template file location.

Browse: Displays the Select Template dialogue box where you can access template files that are not available in the Select a Template list.

Use of Wizard: Set up a drawing using a step-by-step guide. There are two wizards.

A. Quick Setup Wizard: It deals through two steps for new drawing i.e. units and area.

UNITS

Menu: Format - Units

Command line: units

In auto cad, drawings are drawn at full size. The size is set at the time of printing. But it is possible to select any unit system and precision. AUTO CAD by default uses decimal units. However, unit style is to be changed if any other unit system is required.

LIMITS

Menu: Format - Drawing limits

Command line: limits it sets and controls the drawing boundaries. It is the invisible boundary to fit the drawing.

It should be large enough to contain the drawing and other related parts of it. Limits can be changed whenever required.

ON/OFF/ < Lower left corner ><0, 0>: Enter lower coordinate value and press enter, upper right corner <420, 297>; enter the co-ordinate value and press enter; when limits checking is ON. AUTO CAD rejects attempts to enter points outside the drawing limits.

OFF; Turns off limits checking.

LOWER LEFT CORNER: Specifies the lower left corner for the drawing limits, default lower limit is (0, 0).

UPPER RIGHT CORNER: Specifies the upper right corner for the drawing limits, default upper limit is (420, 297).

B. Advanced Wizard: It deals through seven steps;

1. Units
2. Angles
3. Angle measure
4. Angle Direction
5. Area
6. Title block
7. Layout.

2. SAVE

Command line: save

File menu: Qsave

It saves the drawing under a current file name. The Save Drawing dialogue box is displayed and drawing can be saved under the current file name or a different file name.

3. SAVE AS

Command line: save as

File menu: Save As

It saves a copy of current drawing under new file name.

4. QNEW

Command line: qnew

Starts a new drawing with the option of using a default drawing template file and folder path specified in the Options dialogue box on the Files tab. You can set the default drawing template file or to None.

5. OPEN

File menu: Open

Command line: open

It is used to open an existing drawing file. The Select File dialogue box is displayed. You can open and load a portion of drawing. In the Select File dialogue box, click the arrow next to Open button and choose Partial Open or Partial Open Read Only to display the Partial Open dialogue box.

6. CLOSE

File menu: Close

Command line: close

It closes the current drawing file. If you modified the drawing since it was last saved, AutoCAD prompts you to save or discard changes. You can close the file that has been opened in Read-only mode if you have made no changes or if you are willing to discard changes. To save the Read-only file, you must use the SAVEAS command.

7. CLOSE ALL

Window menu: Close All

Command line: closeall

It closes all the open drawings. A message box is displayed for each unsaved drawing, in which you can save any changes to the drawing before closing it.

8. QUIT

File menu: Exit

Command line: quit

It is used to exit from AutoCAD. Quits the AutoCAD if there have been no changes since the drawing was last saved.

Toolbars and Icons

The commands in the tool bars do the work of creating new objects and editing existing ones. The icons are grouped by action type. For example the Draw tool bar contains tools needed to create objects and Modify tool bar contains functions that modify the existing objects. To find out what a particular icon is meant, place the cursor on top of an icon and wait for a while, a tool tip including short cut key will flash along with the cursor. At the same time, notice the status bar. In place of the co-ordinates display, AutoCAD displays a brief help text narrating the function of the command along with the command name. The icon buttons in the tool bars display further options known as fly-outs (button with an arrow at right bottom corner), they open dialogue boxes and issue commands that require keyboard input.

Drafting settings Tool

menu: Drafting Settings

Command line: dsettings

Drafting settings specifies the settings for a number of drafting aids to help you draw more quickly and precisely. Drafting Settings dialogue box will be displayed which include various tabs to make settings for Snap mode, Grid, Object snaps, polar and object snap tracking, input and selection settings.

SNAP MODE: Controls the invisible grid that restricts the cursor movement to specified intervals. It includes settings to specify Snap X Spacing, Snap Y Spacing, Angle, X Base, Y Base and polar spacing and in addition Snap Type and Style.

GRID MODE: Controls the display of the dot grid that helps to visualize distances. The limits of the grids are controlled by LIMITS command. It includes settings for Grid X Spacing and Grid Y Spacing.

OBJECT SNAP: (OSNAP) Specifies the running object snap modes. When Object Snap mode is on, while in the command, the specified points of the object like Endpoint, Midpoint, Centre, Node, Quadrant, Intersection, Extension, Insertion, Perpendicular, Nearest, Tangent, etc will be indicated at the cursor.

POLAR TRACKING: Sets the angles for polar tracking.

ORTHO: It controls the cursor movement. If ortho mode is on, the cursor movement constrained to the horizontal - vertical directions.

In AutoCAD, its configurations can be customized using Options command and it is also available in the dropdown menu when right clicked in the drawing area. Options dialogue box is displayed and can make settings under different tabs; Files, Display, Open and Save, Plot and Publish, System, User Preferences, Drafting, Selection and Profiles.

Function keys

AutoCAD provides a set of function keys for quick access to certain setting commands.

Function key Function defined in AutoCAD

F1 Online help

F2 Toggles between command window on and off

F3 Toggles between OSNAP on and off

F4 Toggles between Tablet on and off

F5 Switches among Isoplanes Top, Right and Left

F6 Toggles between co-ordinates on and off

F7 Toggles between Grid on and off

F8 Toggles between Ortho on and off

F9 Toggles between Snap on and off

F10 Toggles between Polar Tracking on and off

F11 Toggles between Object Snap Tracking on and off

F12 Dynamic Input on and off

DRAW TOOL COMMANDS

It consists of set of commands that can be used to create new objects like line, arc, rectangle, polygon, circle, ellipse, polyline, hatch, etc.

9. LINE

Draw menu: Line

Command line: line

Short cut key: L

Line command creates one or series of straight-line segments; here each line segment is a separate object. There are various methods of giving inputs for creating a line.

- Point method by picking the first and last point
- Absolute method: In this system the point is specified using X & Y co-ordinates measured from origin.
- Relative Co-ordinate: In this system the point is specified using X & Y co-ordinate the distance of the next point is measured from a previous point.
- Direct Distance Entry: It is an alternative to entering polar or relative co-ordinates. This is an easy and fastest way to specify a length. Specify a point and move the cursor to indicate a direction and then enter the distance from the first point.

10. CIRCLE

Draw menu: Circle

Command line: circle

Short cut key: C

It creates a circle. The default method is to specify the centre point and the radius. In addition,

there are other methods also.

- Centre and Radius: It draws a circle based on a centre point and radius command circle.
- Centre and Diameter: Draws a circle based on a centre point and diameter.
- Three points: Draws a circle based on three points on the circumference.
- Two points: Draws a circle based on a two end points of the diameter.
- Tangent, Tangent, Radius: Draws a circle with a specified radius and tangent to two selected objects.

11. ARC

Draw menu: Arc

Command line: arc

Short cut key: A

It creates an arc and is used to add curved segments to the drawing. There are many ways to give the data to draw arcs.

- Three-point arc: Draws an arc using three specified points on the circumference.
- Start, centre, end point: Draws an arc using start point, centre of arc and end point of arc.

- Start, centre, angle
- Start centre length or chord
- Start, end, radius
- Start, end, starting direction
- Start, end, starting direction.

12. POLYLINE

Draw menu: Pline

Command line: pline

Shortcut key: pl

Polyline is a series of connected line and are segments created as one object, width of the object can also be controlled.

13. RECTANGLE

Draw menu: Rectangle

Command line: rectangle

Shortcut key: rec

It creates a rectangle and it acts as one entity. It can be drawn by picking two opposite corners

or by giving areas and dimensions.

14. POLYGON

Draw menu: Polygon

Command line: polygon

Shortcut key: pol

It creates a regular polygon with the given number of sides and side length.

15. SPLINE

Draw menu: Spline

Command line: spline

Shortcut key: spl

It creates a smooth curve passing through mid-points of segments of polyline.

16. ELLIPSE

Draw menu: Ellipse

Command line: ellipse

Shortcut key: el

Creates an ellipse or an elliptical arc.

17. X- LINE

Draw menu: X-line

Command line: xline

Shortcut key: xl

It creates an infinite line, x lines are commonly used as construction lines.

18. Hatch

Draw menu: Hatch

Command line: hatch

Shortcut key: h

It fills an enclosed area with a pattern.

MODIFY TOOL COMMANDS

It consists of set of commands that can be used to alter the existing objects.

19. ERASE

Modify menu: Erase

Command line: erase

Shortcut key: e

It deletes the selected objects from drawing.

20. MOVE

Modify menu: Move

Command line: move

Shortcut key: m

Objects can be shifted from one place to another place within the drawing area.

21. COPY

Modify menu: Copy

Command line: copy

Shortcut key: co

It creates one or more number of copies of selected objects within the drawing.

22. ROTATE

Modify menu: Rotate

Command line: rotate

Shortcut key: ro

It rotates selected objects around given axis to the given angle or about a base point.

23. MIRROR

Modify menu: Mirror

Command line: mirror

Shortcut key: MI

It creates mirror image of the selected object in selected direction. It helps to complete drawing faster if the object is symmetrical about any axis.

24. OFFSET

Modify menu: Offset

Command line: offset

Shortcut key: O

It creates a new object that is similar to a selected object at a specified distance from the original object.

25. SCALE

Modify menu: Scale

Command line: scale

Shortcut key: sc

It is used to enlarge / reduce the size of the objects equally in the x and y directions as per the scale factor given.

26. STRETCH

Modify menu: Stretch

Command line: stretch

Shortcut key: str

It is used to change the snap and size of the object by pulling or pushing from one side and also to move objects from one place to another place.

27. TRIM

Modify menu: Trim

Command line: trim

Shortcut key: tr

It is used to cut off or erase an object or set of objects precisely at an edge defined by other objects. It can also be used to cut off part of the object in between two defined edges.

28. EXTEND

Modify menu: Extend

Command line: extend

Shortcut key: ex

It extends an object to meet another object.

29. ARRAY

Modify menu: Array

Command line: array

Shortcut key: ar

It creates multiple copies of object in given number of rows and columns or around an imaginary circle.

30. BREAK

Modify menu: Break

Command line: break

Shortcut key: br

This method is used to cut an object into two parts at selected point or to remove part of the object in between two selected points.

31. EXPLODE

Modify menu: Explode

Command line: explode

Shortcut key: x

It converts polyline, blocks and hatch objects into discrete objects.

32. CHAMFER

Modify menu: Chamfer

Command line: chamfer

Shortcut key: cha

It connects two non-parallel lines by extending them to intersect or to join with a bevelled line at specified distance from intersection.

33. FILLET

Modify menu: Fillet

Command line: fillet

Shortcut key: f

It used for filleting connects the two objects with a round arc of a specified radius.

NAVIGATING COMMANDS**34. ZOOM**

View menu: Zoom

Command line: zoom

Shortcut key: z

It is used to enlarge and reduce the view of the object in different ways. Zooming does not change absolute size of the object but it changes the size of view with in graphic data.

35. PAN

View menu: Pan

Command line: pan

Shortcut key: p

It moves the drawing display from one place to another to option selected.

Using text

Text plays an important role in drawing. It is used in title blocks, to give specifications or to make annotations in the drawing. Texts may be either Single line or Multiline text. Text style: the group of texts can be assigned a definite set of properties using named text styles.

Dimensioning

Dimensioning plays a vital role in any drawing and is necessary to specify the dimensions of the objects in the drawing. Similar to text styles, dimension styles can also be created with specific set of properties like size and type of arrow head, text style, colour, units, precision and alignment of dimension text, etc. dimensions may be linear, aligned, angular, radius, diameter.

Leader: It is used to create an arrowed line that connects annotation to a feature. It is used to label the objects.

Block

It is a group of objects associated together to form a single object. This block can be inserted, scaled and rotated whenever required. This single object can be saved it as a block by giving name to an object. Later this name can be used to insert block.

Layer

When group of objects are created layer command is used to assign various line type colours to various objects. This group of objects can also be made visible and invisible.

Menu: Format

Layer Command: Layer or La

It will display a layer and line type dialog box.

New: Click on new button to create new layer. Enter name in the layer name box. To create more than one layer names separated by command don't use existing layer names. Again click new to choose new layer. Assign colour and line type to the layer.

Current: Click current button to make the selected layer the current layer.

On and off: ON is used to draw objects and they are visible OFF is used to make the drawn objects in that layer invisible.

Freeze and thaw: A thaw layer is invisible and excluded from regeneration and plotting. A thawed layer is visible and available for regeneration and plotting.

Lock and unlock; If the layer is locked. The objects drawn in the locked layer cannot be modified. If it is unlocked it can be modified.

Colour: It can be used to give suitable colour to the selected layer.

Delete: Removes selected layer from the list.

Line type: Select line type and displays a dialog box. In this box, different line types can be assigned to layer. It creates loads and sets line types to layer.

Match Properties

It copies or matches the properties of one object to one or more object.

Modify: Match properties

Command: Match prop or painter

Select source object: Select the object whose properties are to be copied. Settings/<select destination objects(s)>: Enter settings or select one or more objects which are to be changed.

Settings: displays a dialog box and specify the properties to be copied.

MODULE 2

DRAWINGS OF BUILDING COMPONENTS

The drawings of different components of a building are to be prepared for the data given using AutoCAD software.

A. CROSS SECTION OF MASONRY WALL FOUNDATION, RCC COLUMNS WITH ISOLATED AND COMBINED FOOTINGS

Exercise 2.1

Draw a cross section of a S.S. Masonry foundation to be provided for a load bearing wall 300mm thick in Burnt Brick Masonry in superstructure of a residential building. Use following data:

- | | |
|--|---|
| i. Width of foundation = 1.20m | v. Width of first footing above PCC = 1.05m |
| ii. Depth of foundation below GL = 1.20m | vi. Depth of first footing above PCC = 0.375m |
| iii. Width of PCC = 1.20m | xi. Width of plinth wall = 0.45m |
| iv. Thickness of PCC in 1:3:6 = 75mm. | xii. Depth of plinth wall = 0.60m |
| vii. Width of second footing = 0.90m | xiii. Thickness of DPC in 1:2:4 = 100mm. |
| viii. Depth of second footing = 0.375m | |
| ix. Width of third footing = 0.75m | |
| x. Depth of third footing = 0.375m | |

Solution: Refer Fig. 2.1

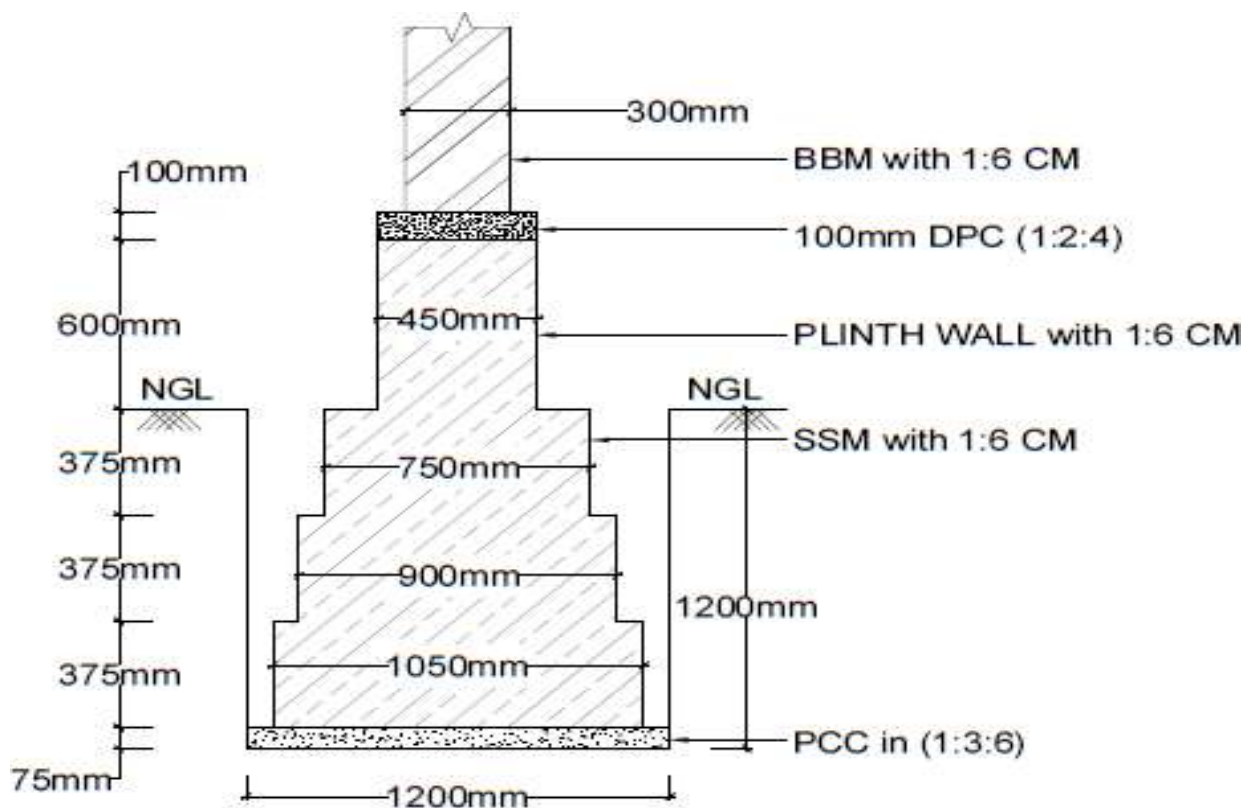

CROSS SECTION OF SIZE STONE MASONRY FOUNDATION FOR MAIN WALL (Fig:2.1)

Exercise 2.3

Prepare a working drawing for an isolated column footing (RCC) for a column size 300mm x 300mm reinforced with #8 of 12mm HYSD- steel as main bars together with 2 legged 8φ stirrups at 200c/c.

Details of footing: Size of footing is 1.6m x 1.6m and the thickness of the footing at the face of the column is 450mm which reduces to 300mm at the edge of footing. The mat comprises of 10φ TOR- steel at 100 c/c both ways. The footing is provided with PCC bed in 1:3:6 of thickness 75mm. Depth of foundation is 1.5m from natural ground level.

Solution: Refer Fig. 2.3

SQUARE ISOLATED COLUMN FOOTING(Fig:2.3)

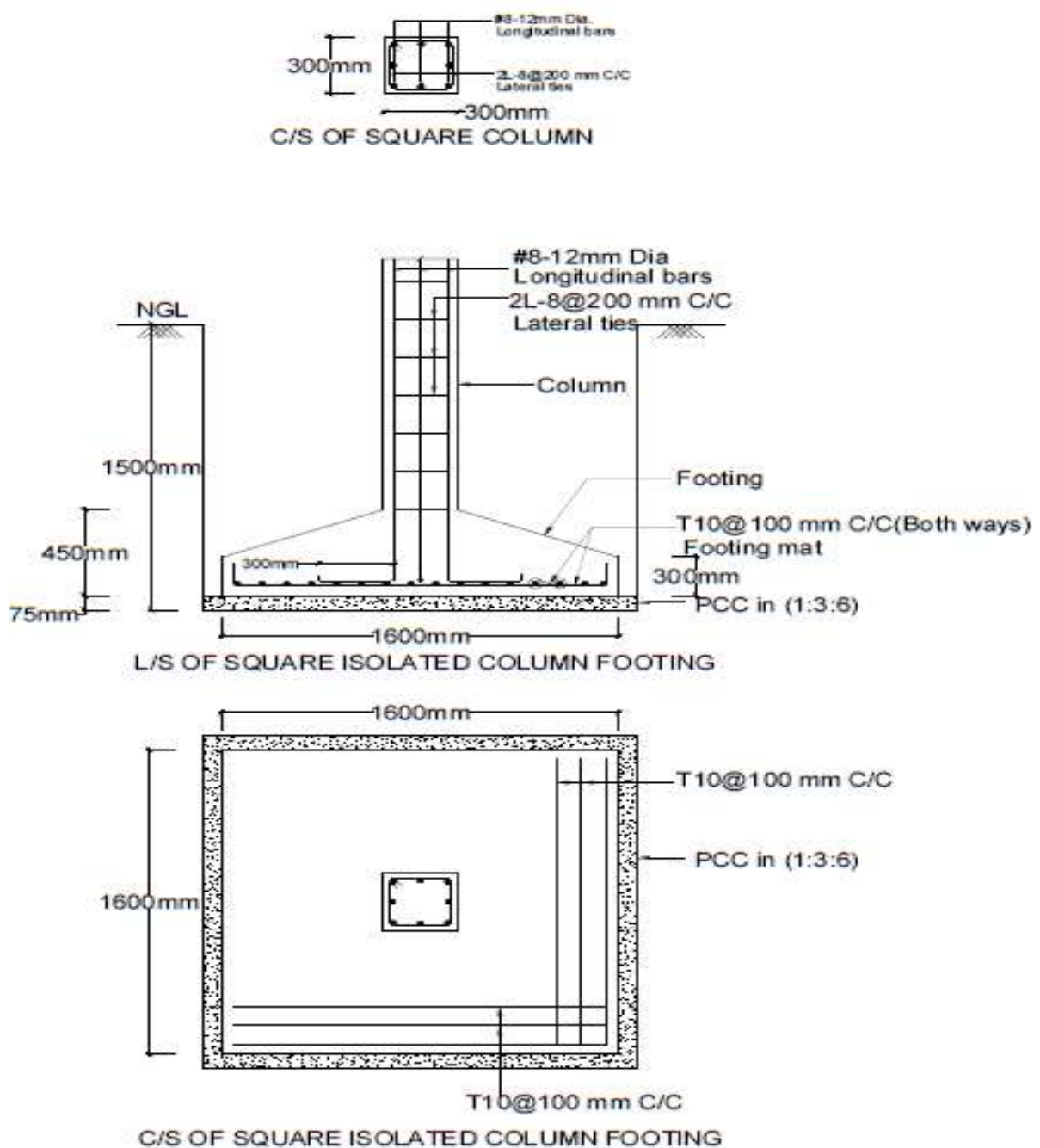

Exercise 2.4

Prepare a working drawing for an isolated rectangular RCC column and footing has the following details:

Column size: (400 x 600) mm. Size of footing: 2m x 3m of uniform thickness 450mm. Depth of foundation below GL = 1.5m, Height of column to be shown above GL = 1.0m, Thickness of PCC bed in 1:3:6 = 75mm,

Details of reinforcement:

Column: #8 - 16 ϕ as main bars with 2L - 8 ϕ @ 150 c/c lateral ties, Footing: Longer direction steel - 12 ϕ @ 130 c/c, Shorter direction steel - 12 ϕ @ 220 c/c.

Solution: Refer Fig. 2.4

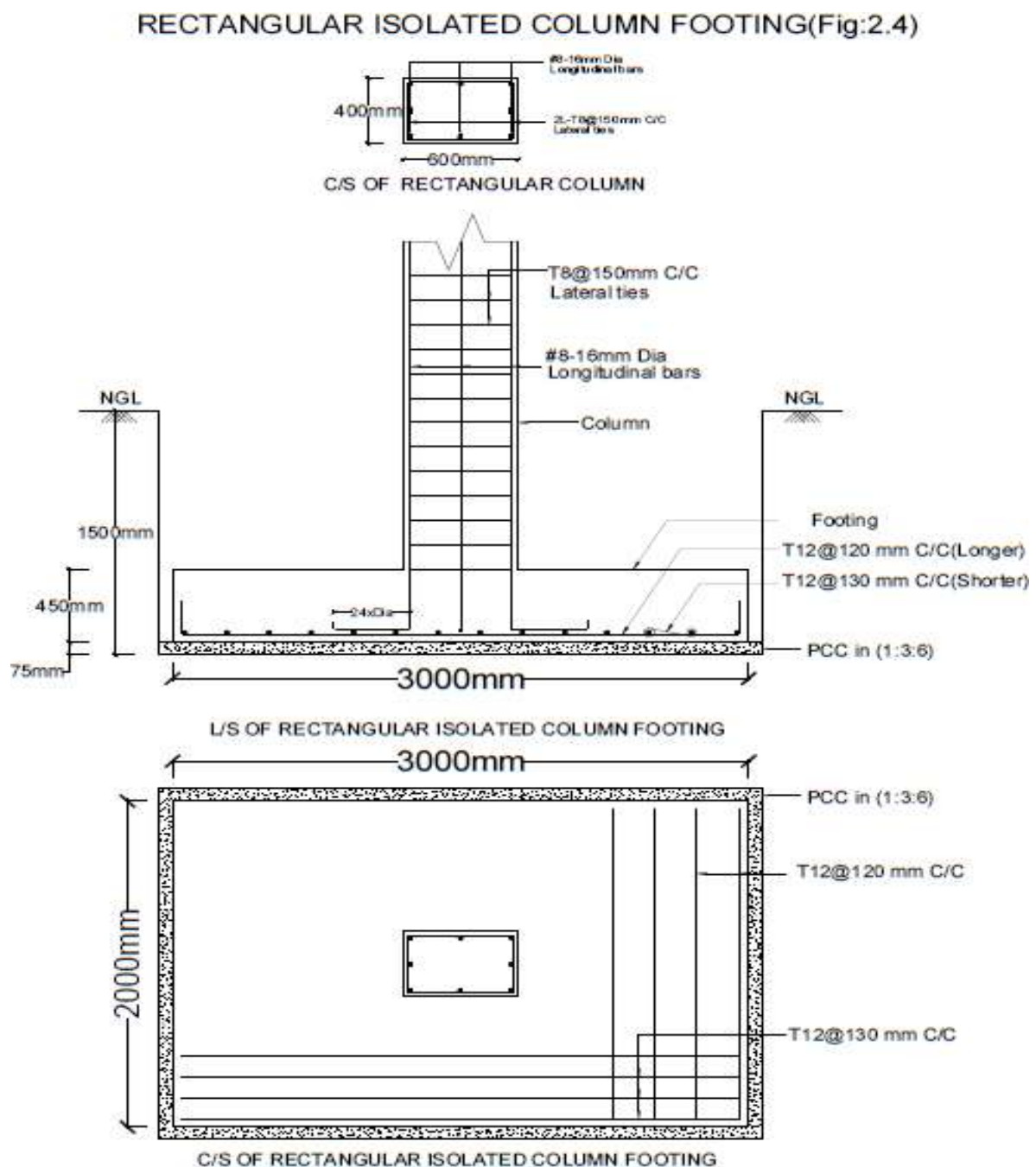

Exercise 2.5

Draw plan, sectional elevation and cross section of a slab type combined footing with the given details:

Size of columns = (400 x 400) mm, Depth of footing = 600mm, Size of footing = 2m x 4m

Centre to centre distance between the columns = 2m, Thickness of PCC bed in 1:3:6 =

100mm, Column reinforcement details – longitudinal steel of #8 - 20 ϕ with lateral ties of 2L - 8 ϕ @ 200 c/c

Footing reinforcement details – bottom reinforcement of 12 ϕ @ 100 c/c both ways and top reinforcement of 12 ϕ @ 150 c/c both ways

Solution: Refer Fig. 2.5

SLAB TYPE COMBINED FOOTING(Fig:2.5)

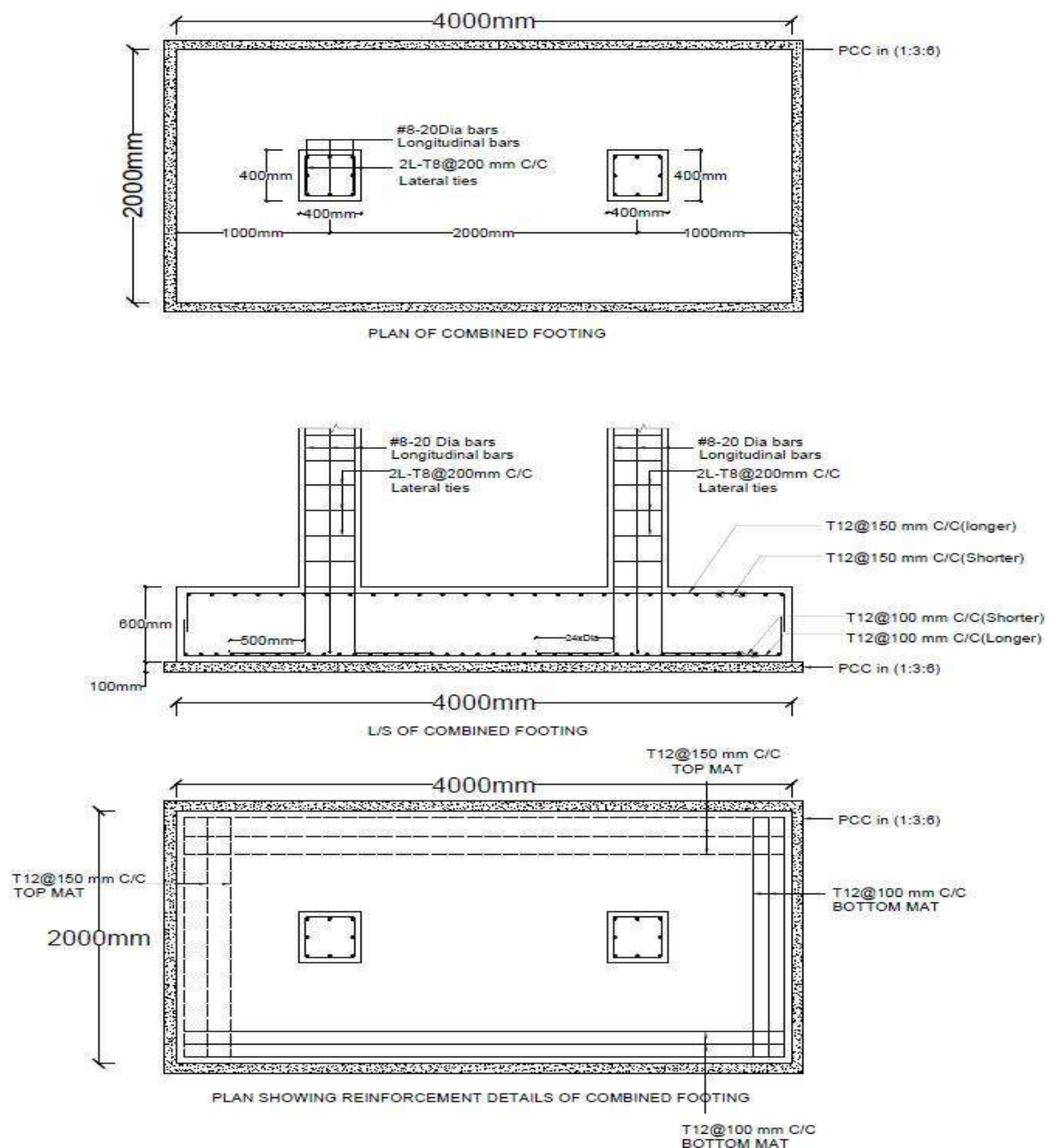

B. DIFFERENT TYPES OF BONDS IN BRICK MASONRY**Exercise 2.6**

Draw two consecutive courses for corner joints of the following walls in English bond.

(a) One brick thick wall i.e., 200 x 200

(b) One and half thick wall i.e., 300 x 300.

Solution: Refer Fig. 2.6a for one brick thick wall

Refer Fig. 2.6b for one and half brick thick wall

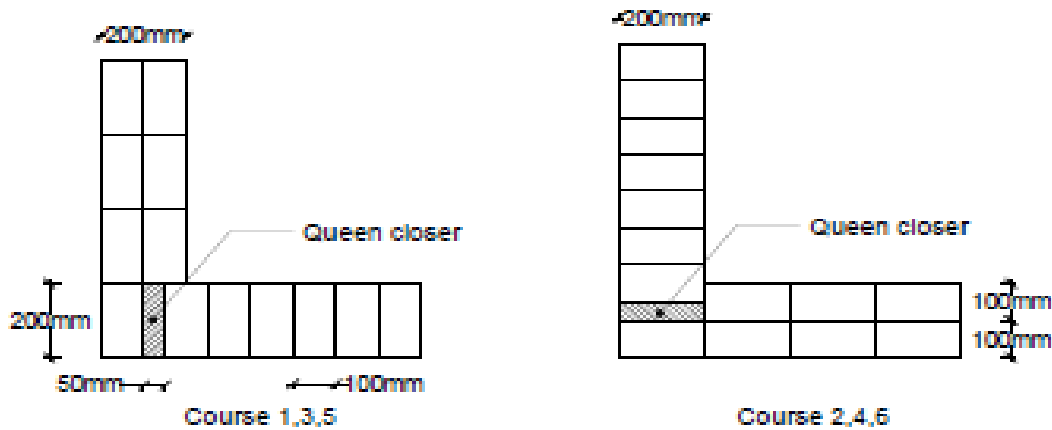

ENGLISH BOND
ONE BRICK WALL 200X200(Fig:2.6a)

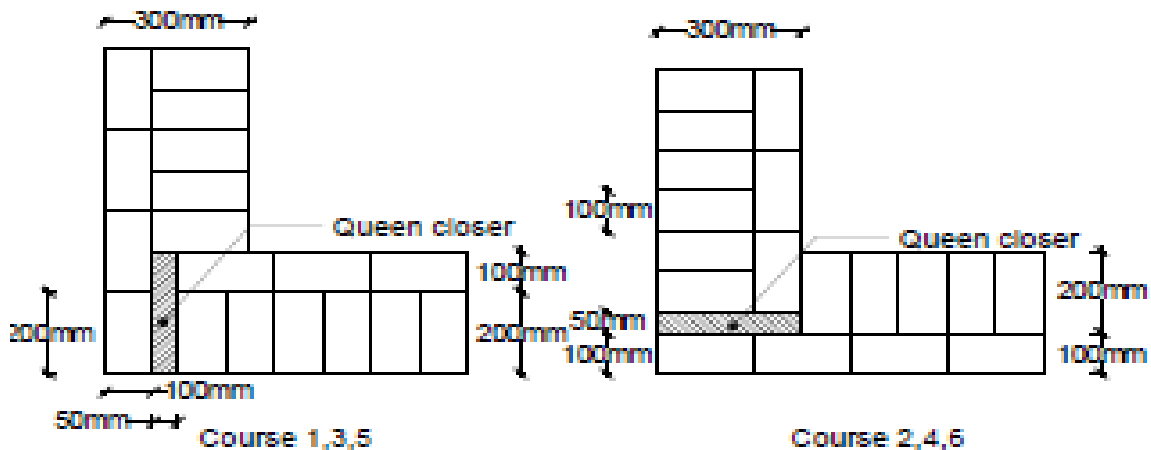

ENGLISH BOND
ONE AND HALF BRICK WALL 300X300(Fig:2.6b)

Exercise 2.7

Draw plan of two consecutive courses for corner joints of the following walls in Double Flemish bond.

(a) One brick thick wall i.e., 200 x 200

(b) One and half thick wall i.e., 300 x 300.

Solution: Refer Fig. 2.7a for one brick thick wall

Refer Fig. 2.7b for one and half brick thick wall

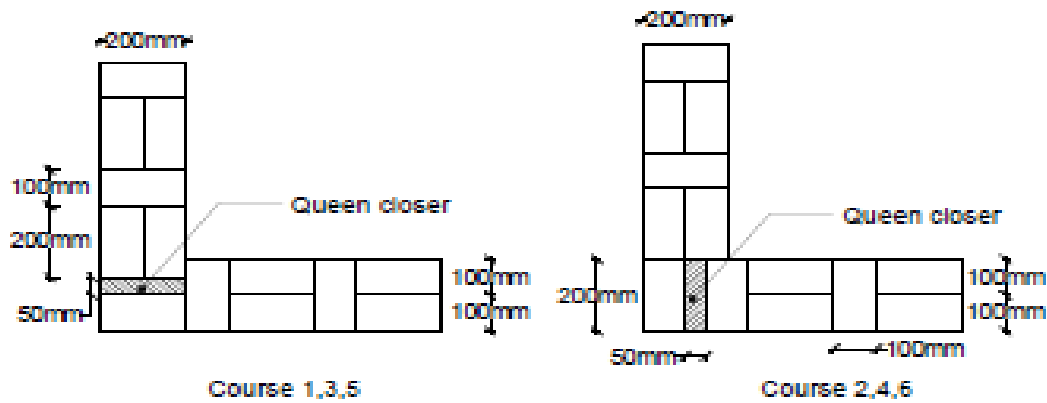

**DOUBLE FLEMISH BOND
ONE BRICK WALL 200X200(Fig:2.7a)**

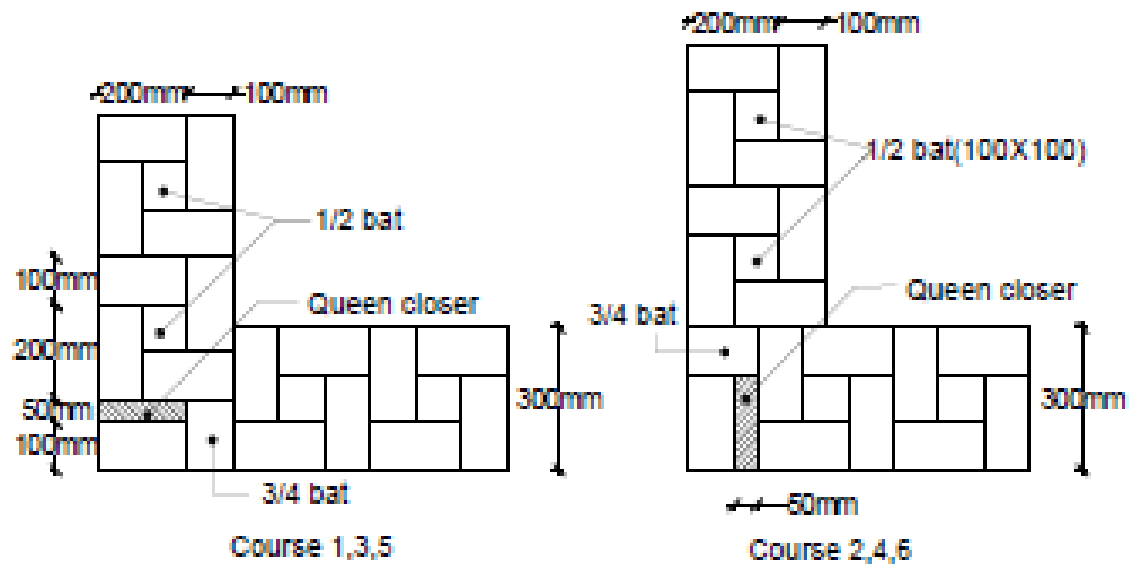

**DOUBLE FLEMISH BOND
ONE AND HALF BRICK WALL 300X300(Fig:2.7b)**

Exercise 2.8

Draw plan and elevation of two alternate courses of a one brick thick wall in Header bond.

Solution: Refer Fig. 2.8

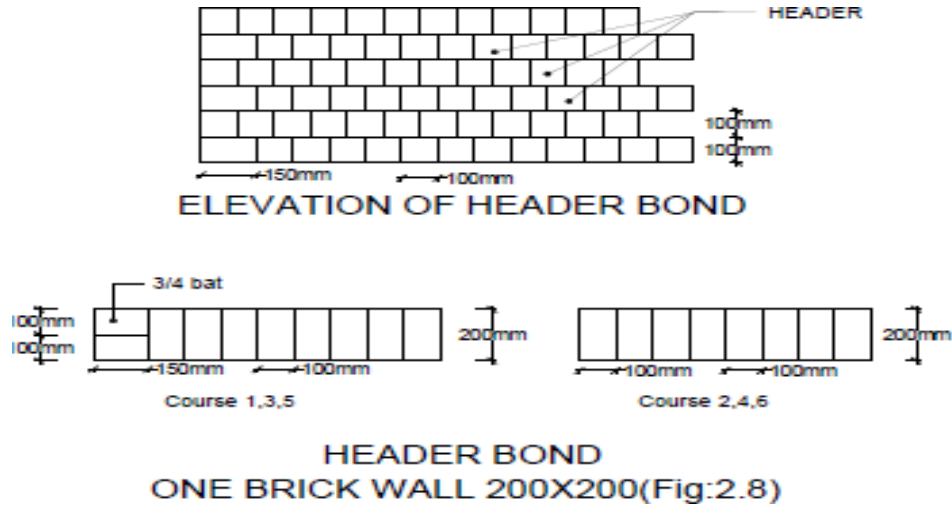

Exercise 2.9

Draw plan and elevation two alternate courses and elevation of a half brick thick wall in Stretcher bond.

Solution: Refer Fig. 2.9

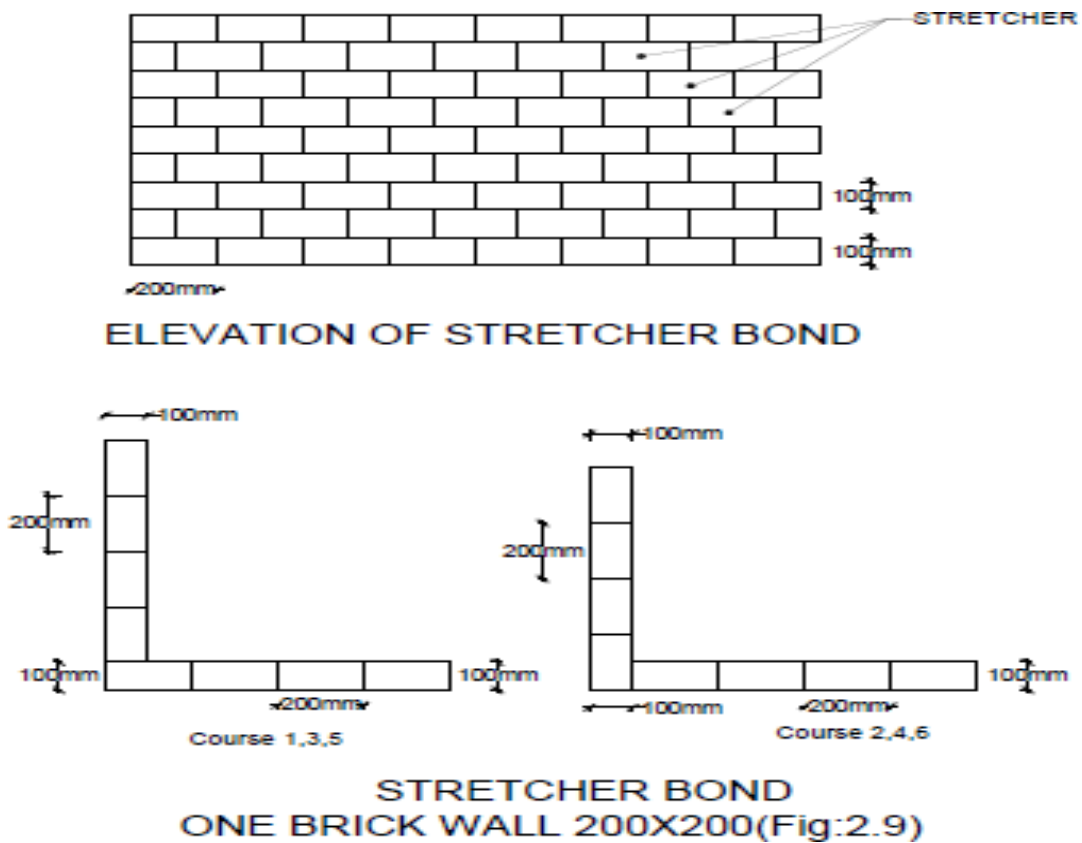

C. DIFFERENT TYPES OF STAIRCASES

Exercise 2.10

Draw plan and sectional elevation of RCC dog legged staircase for an office building which measures 3m x 5.5m. The vertical distance between the floor is 3.3m (including landing). Thickness of the floor slab is 150mm. Provide steps with tread of 300mm and rise of 150mm. Thickness of waist slab and landing slab is 150mm. Width of stair is 1.5m. Reinforcement details: main steel: $10\phi @ 125$ c/c spacing and distribution: $8\phi @ 250$ c/c spacing.

Solution: Refer Fig. 2.10

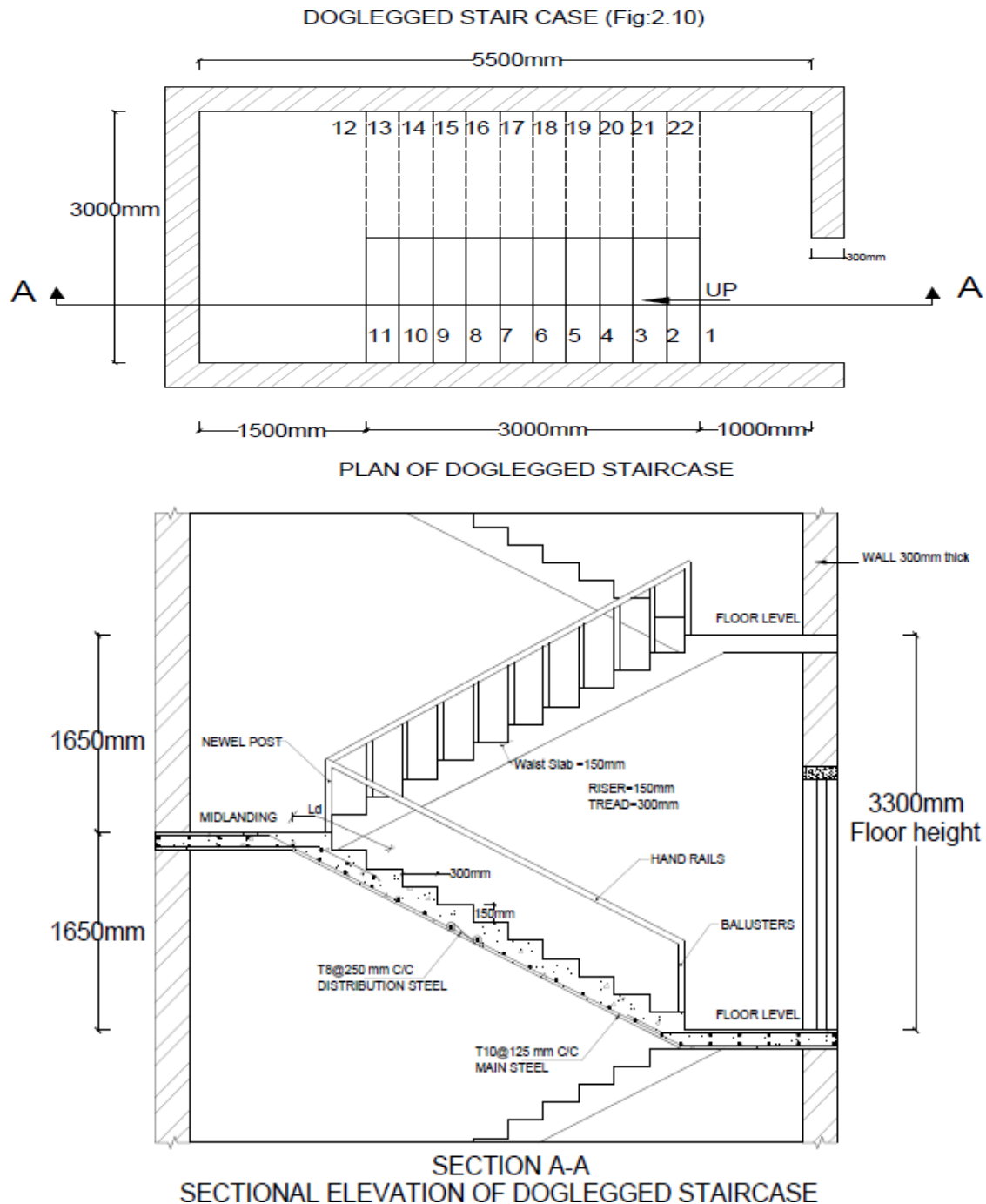

Exercise 2.11

Draw plan and sectional elevation of an open newel stair with a rectangular well for an office building with the following data:

Inside dimensions of staircase = 4.5m x 5.4m.

Height between the floors is 3.6m.

Thickness of the floor slab and landing slab is 150mm.

Width of landing=1.5m.

Width of stair = 1.5m.

Tread=300mm, riser=150mm.

Waist slab thickness = 150mm.

Reinforcement details: Main steel: 12 ϕ @ 150 c/c spacing and Distribution: 8 ϕ @ 250 c/c spacing.

Solution: Refer Fig. 2.11

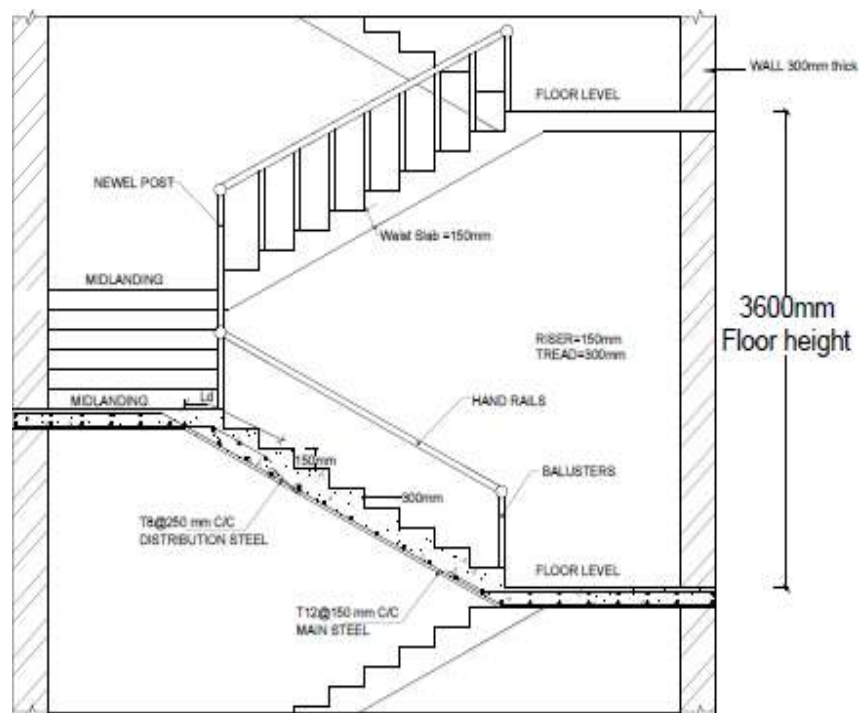
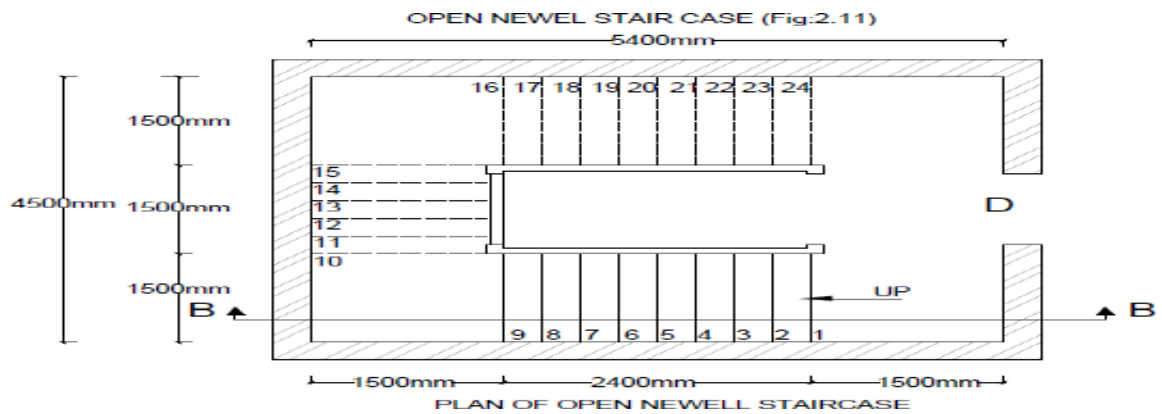

D. LINTEL AND CHEJJA**Exercise 2.12**

Draw the longitudinal section and cross section of RCC lintel monolithically cast with sunshade from following data:

Projection of the sunshade from the face of the wall = 600mm

Thickness at fixed end = 150mm

Thickness at free end = 75mm

Main tensile bars: $8\phi @ 150$ c/c

Distribution bars: $8\phi @ 200$ c/c

For RCC lintel (200 x 200) mm with #4 - 12ϕ at tension zone and stirrups of 2L - $8\phi @ 150$ c/c. The sunshade provided over a 3m wide window.

Solution: Refer Fig. 2.12

LINTEL AND SUNSHADE (Fig:2.12)

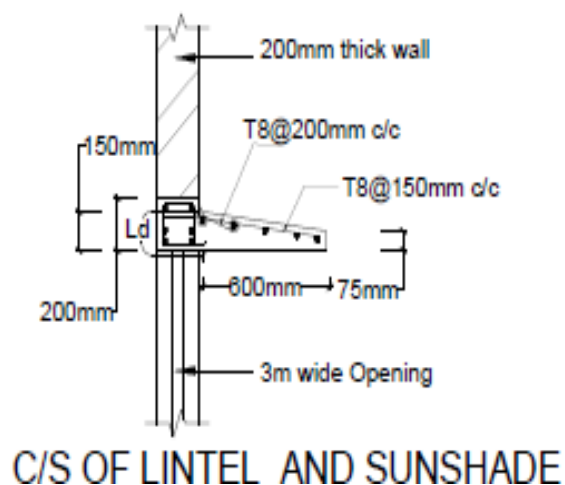
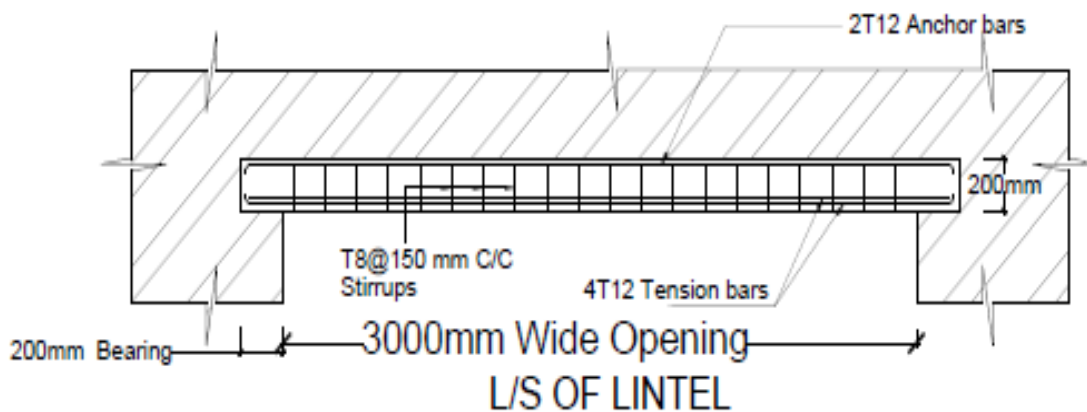

Exercise 2.13

Sketch the reinforcement details for the lintel beam with chejja for 3m wide opening. Size of lintel beam (300x300) mm. Lintel is provided with #5 of 12 ϕ bars in tension zone and 2 legged vertical stirrups of 8 ϕ at 150 c/c.

Chejja details: projection- 1m; thickness at supports- 110mm and at end- 90mm; main steel provided is 12 ϕ @ 150 c/c and distribution steel 10 ϕ @ 150 c/c.

Solution: Refer Fig. 2.13

LINTEL AND CHEJJA (Fig:2.13)

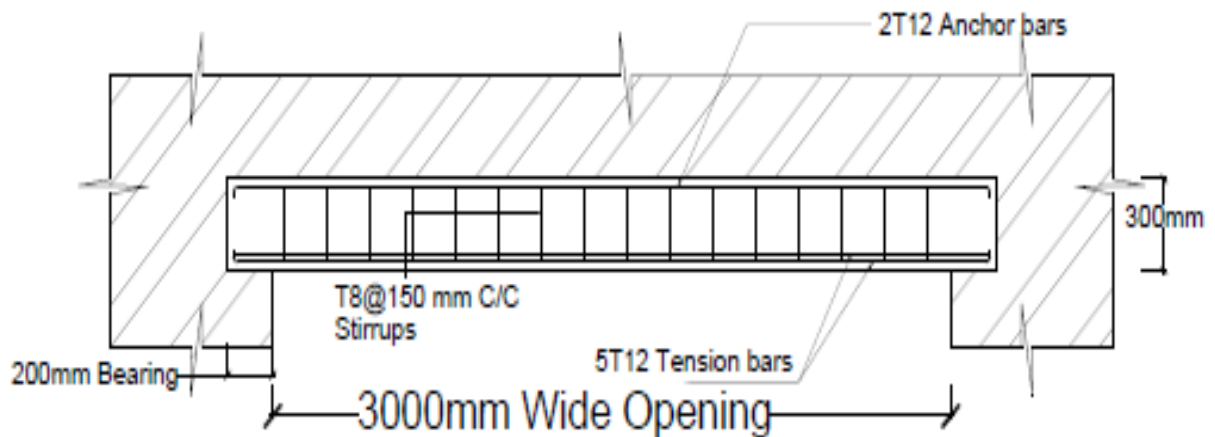

L/S OF LINTEL

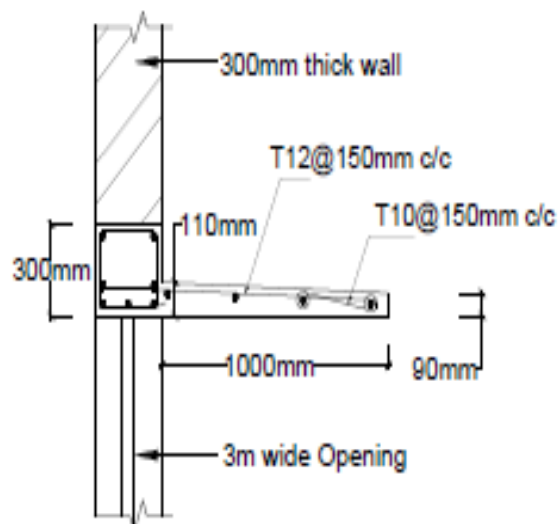

C/S OF LINTEL AND CHEJJA

E. RCC SLABS AND BEAMS

Exercise 2.14

Draw the longitudinal section and cross section of a rectangular RCC beam simply supported with the following data:

Clear span = 4.8m, Bearing at the supports = 300mm, Width of beam = 300mm, Overall depth of beam = 500mm.

Main reinforcement consists of #5 - 20φ bars in two layers, Provide #2 - 12φ as anchor bars.

Stirrups: 2L 8φ @ 180 c/c near the supports up to 1.20m and @ 220 c/c in the remaining portion.

Solution: Refer Fig. 2.14

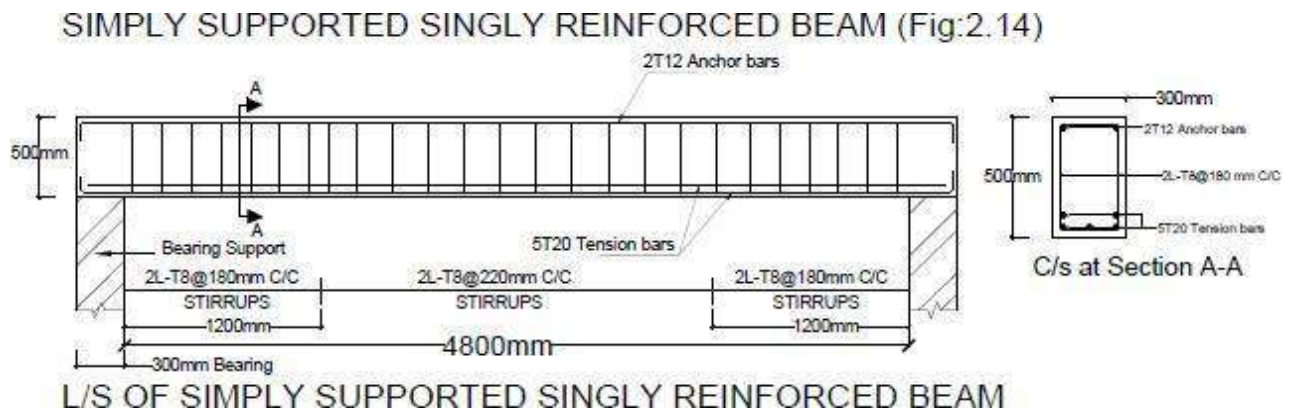

Exercise 2.15

Draw a detailed longitudinal section, a cross section near the supports and a section at the middle of the span of a simply supported doubly reinforced beam for the following data:

Clear span = 5.4m, Bearing over the supports = 300mm, Size = 300 x 800 mm

Main reinforcement tensile: #7 - 25φ. 4 straight and 3 bent up @ 1400mm from support.

Compression reinforcement: #4 - 25φ.

Spacer bars=25 φ, Side face reinforcement=#2-12φ

Shear reinforcement: 2L - 12φ @ 150 c/c for a distance of 1.5m from the support and 2L - 12φ @ 300 c/c for remaining middle portion.

Solution: Refer Fig. 2.15

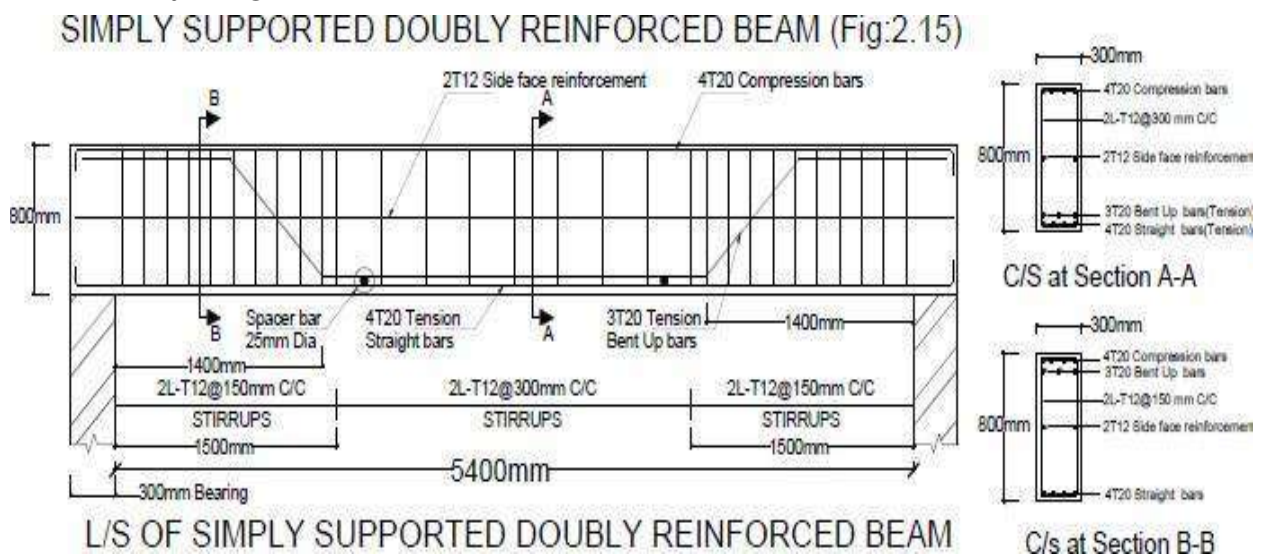

Exercise 2.16

Draw longitudinal section and cross section of a cantilever beam from the following data:

Clear projection from the face of RCC column = 2500mm

Size of column = 300mm x 300mm

Size of beam at fixed end = 300mm x 300mm

Size of beam at free end = 300mm x 150mm

Reinforcement main bars: #5 - 20 ϕ with 2 bars curtailed at 1500mm from the support and show the curtailment plan.

Compression bars: #3 - 16 ϕ

Stirrups: 2L - 6 ϕ @ 200 c/c up to 1000mm from support and @ 300 c/c in remaining length.

Solution: Refer Fig. 2.16

CANTILEVER BEAM (Fig:2.16)

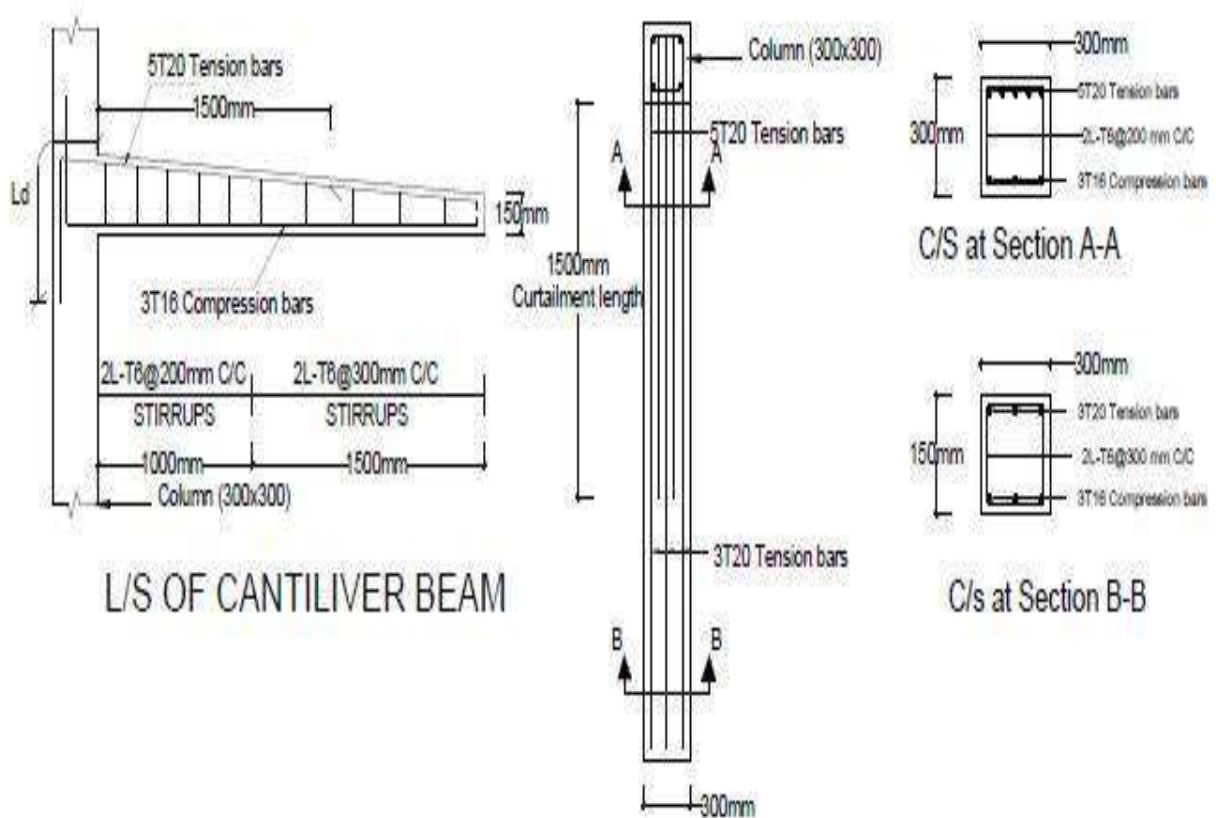

PLAN SHOWING CURTAILMENT DETAILS

Exercise 2.17

Draw cross section and plan of one-way roof slab showing the details of reinforcement for the following data:

Clear span = 4m, Length of slab = 10m

Thickness of slab = 130mm, Bearing wall = 200mm

Main reinforcement: 12 ϕ @ 250 c/c with alternate bars bent up.

Distribution reinforcement: 8 ϕ @ 200 c/c.

Solution: Refer Fig. 2.17

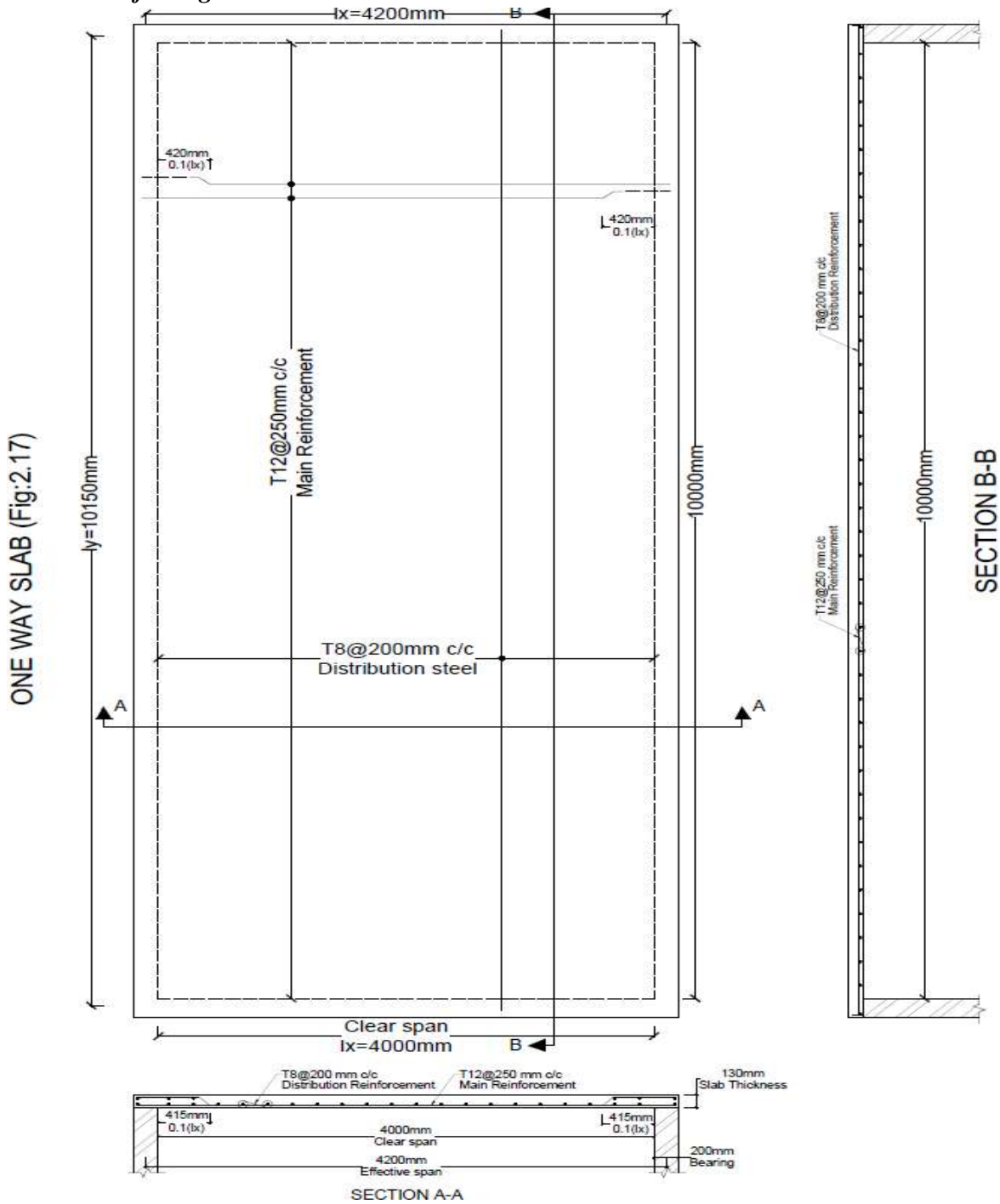

Exercise 2.29

One-way continuous slab has been provided for a hall of clear dimensions 8m x 14.25 m. The slab is supported on RCC beams. The following details are given.

C/C distance of supporting beams = 3.5m, Column dimensions on which beam rests = 250mm x 500mm, C/s of beams = 250mm x 600mm, Slab thickness = 150mm, Beam depth is inclusive of slab depth.

Main positive reinforcement at the end and interior panels = 10φ @ 120 c/c

Main negative reinforcement at all supports = 10φ @ 120 c/c.

Distribution steel = 8φ @ 250 c/c.

Draw cross section and plan showing the details of reinforcement (Bottom & top).

Solution: Refer Fig. 2.18

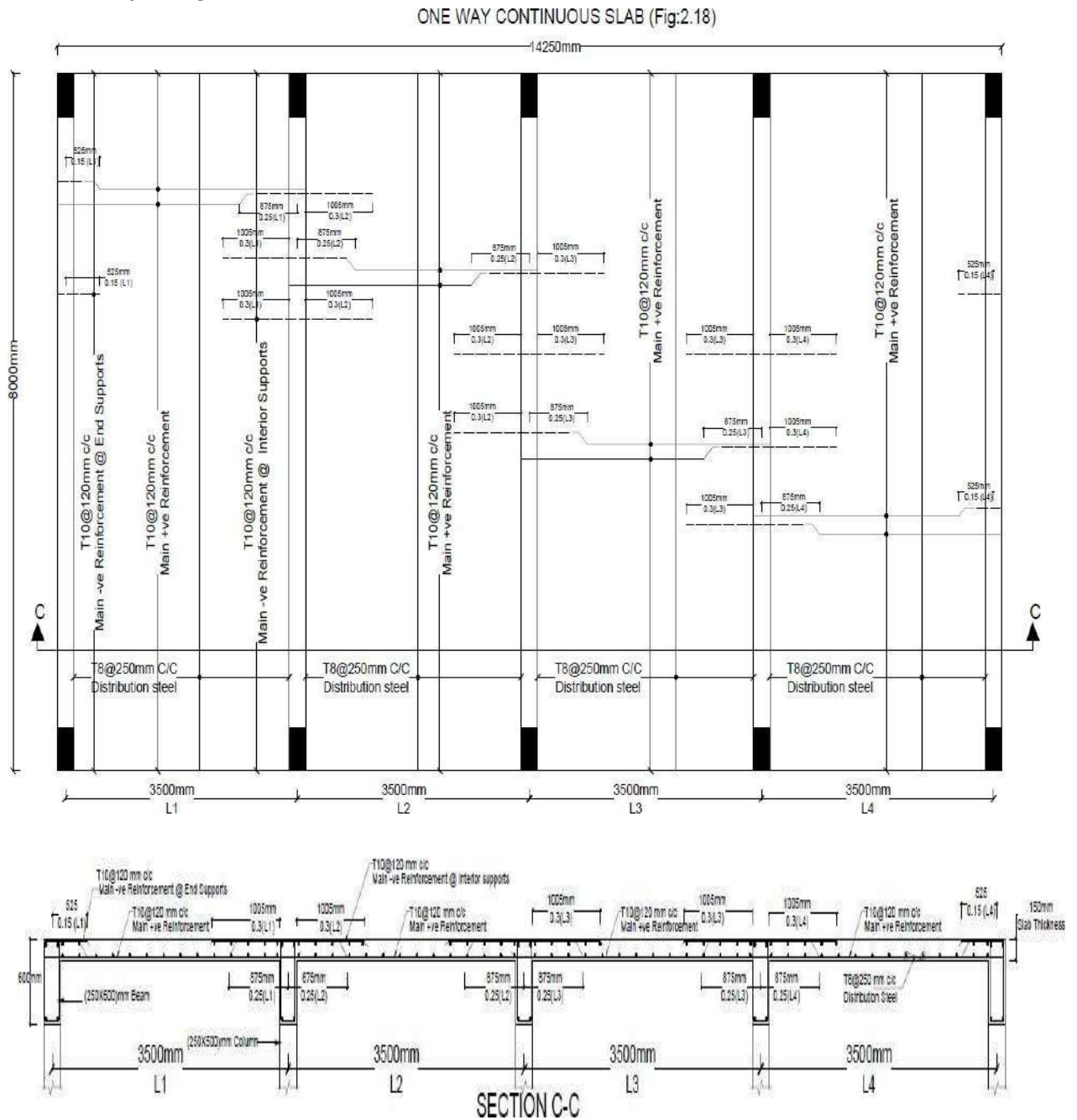

Exercise 2.30

A simply supported two way slab is supported on all sides by using 230mm thick wall. The dimension of two-way slab is 3m x 4m (Clear). Following are the reinforcement details: Along shorter span: $10\phi @ 125$ c/c, Along longer span: $10\phi @ 150$ c/c, Negative steel for shorter span: $10\phi @ 250$ c/c, Negative steel for longer span: $10\phi @ 300$ c/c, Alternative bars are cranked, Corner mats are $8\phi @ 150$ c/c along shorter span and $8\phi @ 200$ c/c along long span, Thickness of slab is 150mm.

Draw plan showing reinforcement and cross section along longer & shorter span.

Solution: Refer Fig. 2.19

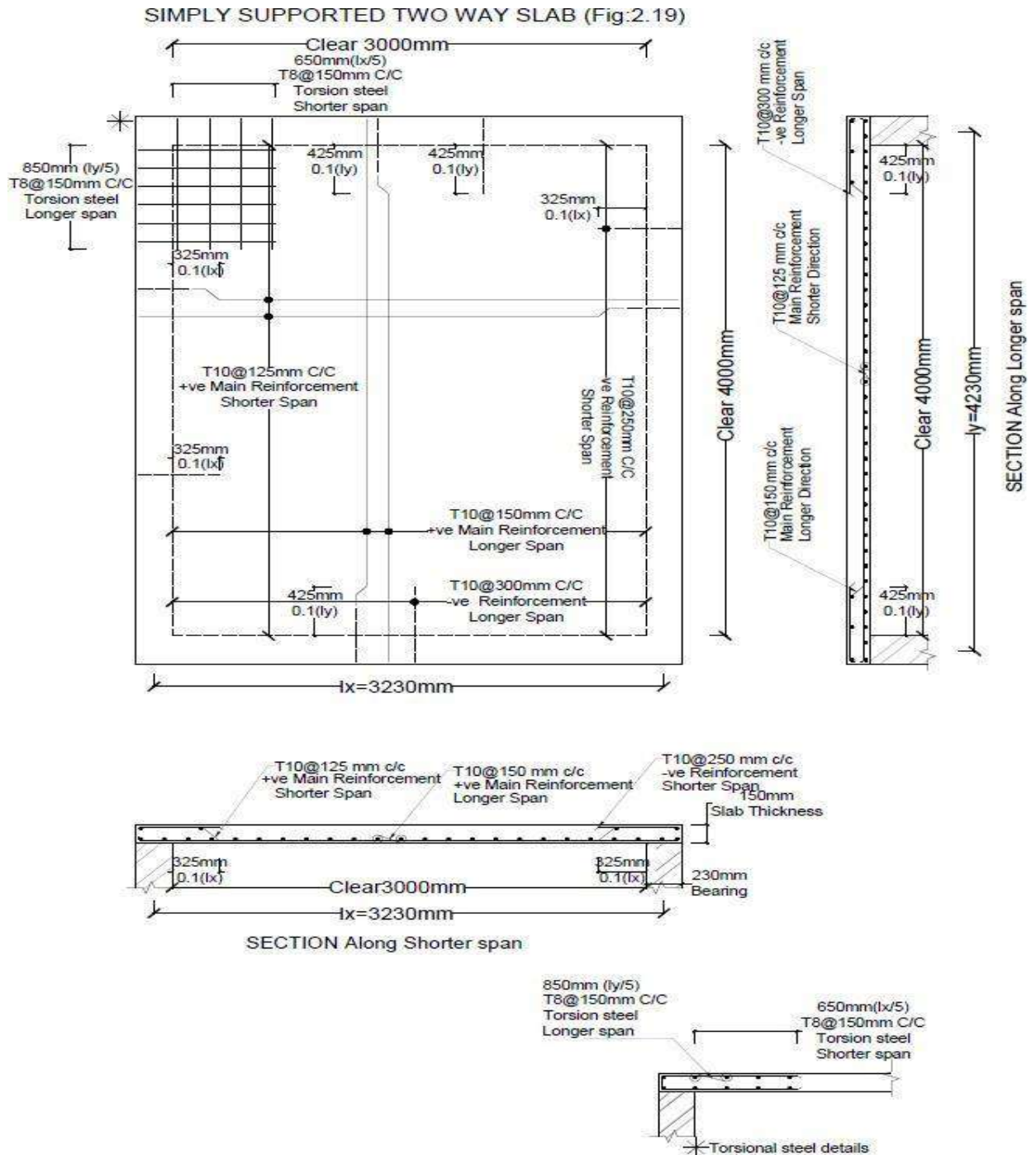

F. CROSS SECTION OF PAVEMENT

Exercise 2.20

Sketch the cross section of a flexible pavement having the following particulars:

Width of carriage way = 3.75m, Camber (@ 2%) = 38mm, Width of Shoulder = 1.5m, Granular sub-base (GSB) thickness = 300mm, Base course thickness = 225mm, Thickness of Binder course = 70mm, Thickness of Surface course = 40mm, Total thickness of the pavement = 635mm.

Solution: Refer Fig. 2.20

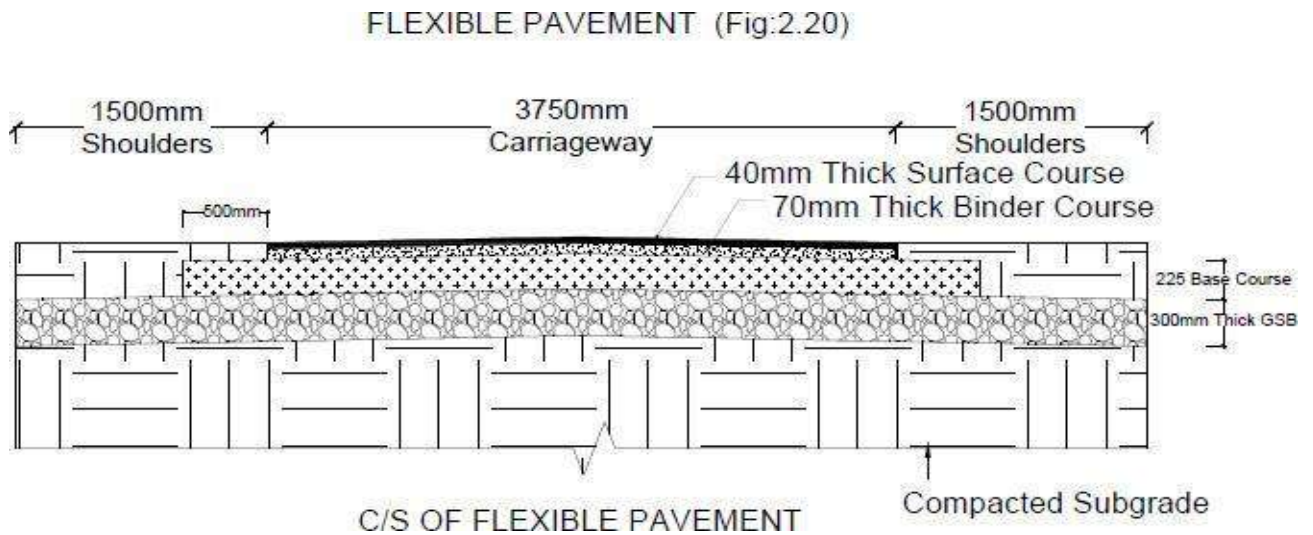

Exercise 2.21

Sketch the cross section of a rigid pavement in heavy rainfall area having the following particulars:

Width of carriage way = 3.75m, Camber (@ 2%) = 38mm Width of Shoulder = 1.5m, Granular sub-base (GSB) = 250mm thick, Dry lean concrete sub-base = 150mm thick, Paving Quality Concrete layer = 240mm thick, Total thickness of the pavement = 640mm.

Solution: Refer Fig. 2.21

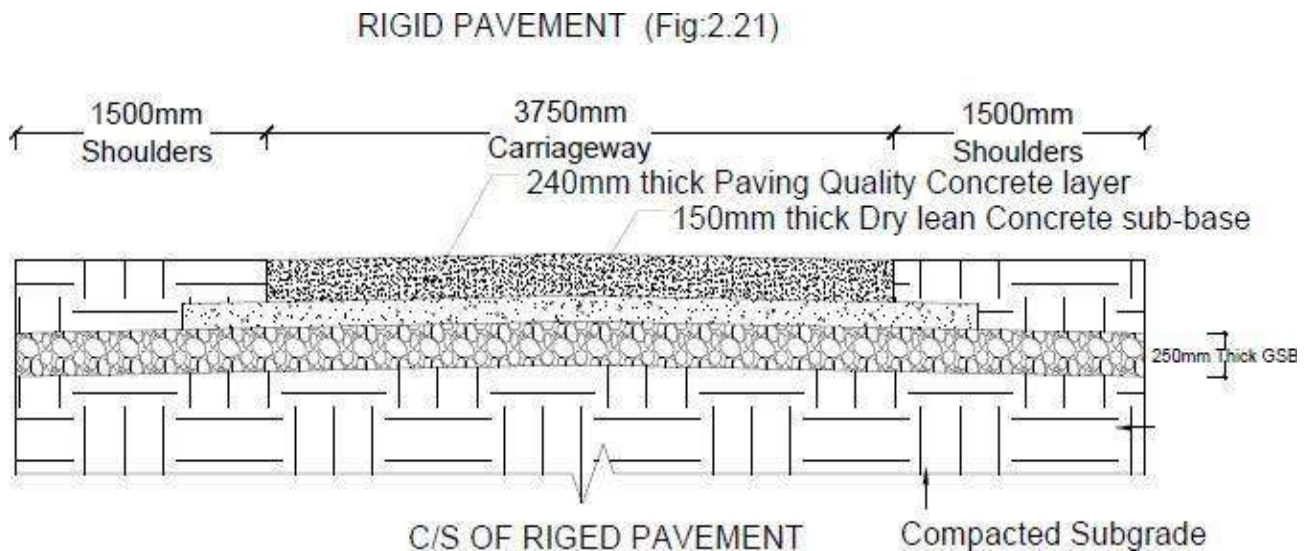

G. SEPTIC TANK AND SEDIMENTATION TANK

Exercise 2.22

Draw plan and cross section of the septic tank for 25 users. The details are given below: Size (clear) of the septic tank (L x B) = (2m x 0.9m)

Depth of liquid = 1.4m

Free board = 0.3m

Thickness of PCC bed in 1:3:6 = 0.2m

Inlet and outlet pipe: 100mm diameter S. W. pipe

Thickness of brick wall up to 0.6m height is 300mm and for remaining height it is 200mm.

Thickness of RCC Baffle slab = 40mm

RCC slab of 75mm thick is provided with 50mm diameter C. I. ventilating pipe

Bed slope: 1 in 20

Solution: Refer Fig. 2.22

SEPTIC TANK (Fig:2.22)

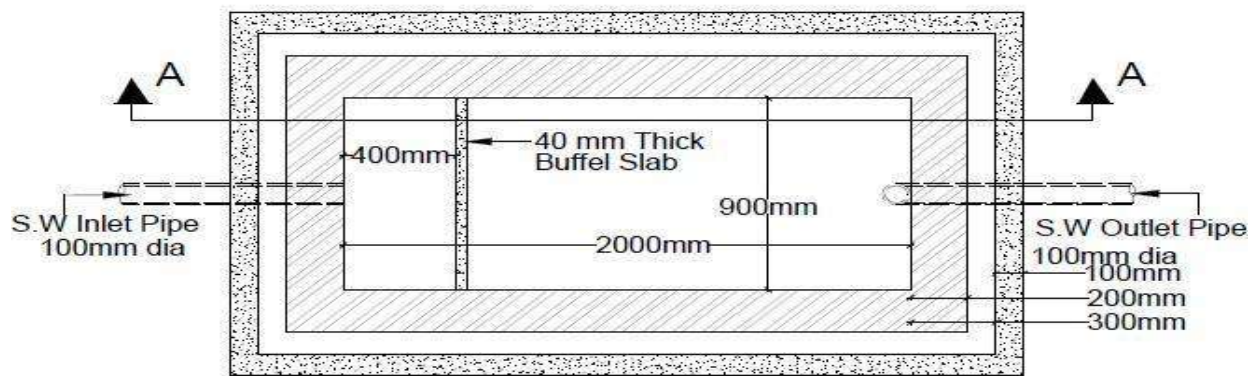

PLAN OF SEPTIC TANK

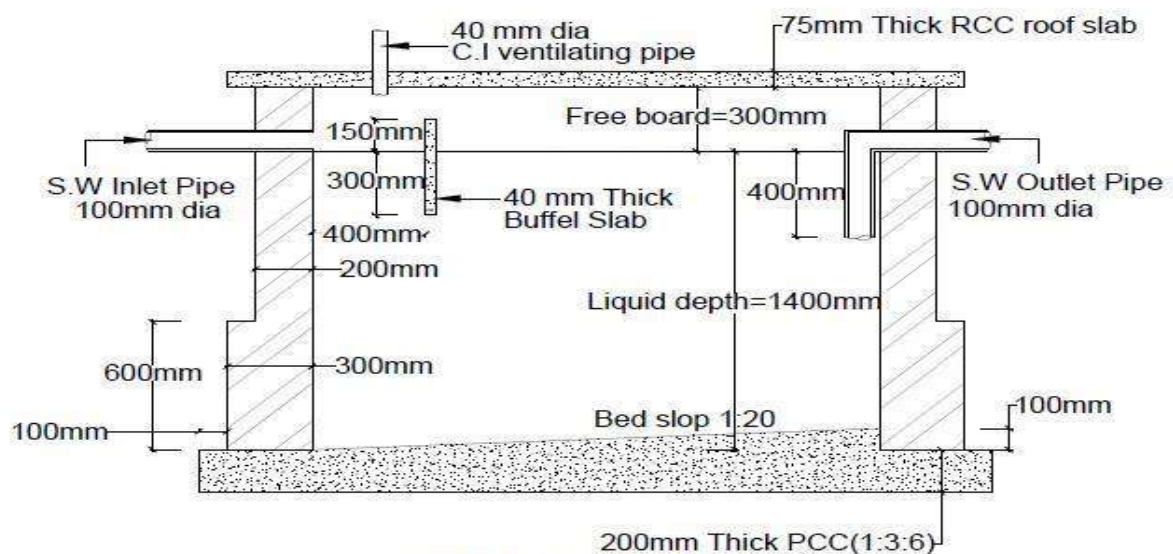

SECTION A-A

Exercise 2.23

Draw the cross section of the peripheral feed circular sedimentation tank mechanical sludge removal equipment for given data.

Diameter of the tank = 17.5m

Depth of the tank = 3.0m

RCC wall & slab thickness = 200mm

Diameter of influent pipe, effluent pipe and sludge pipe = 200mm.

Bed slope=8%.

Thickness of RCC Baffle slab = 40mm.

Solution: Refer Fig. 2.23

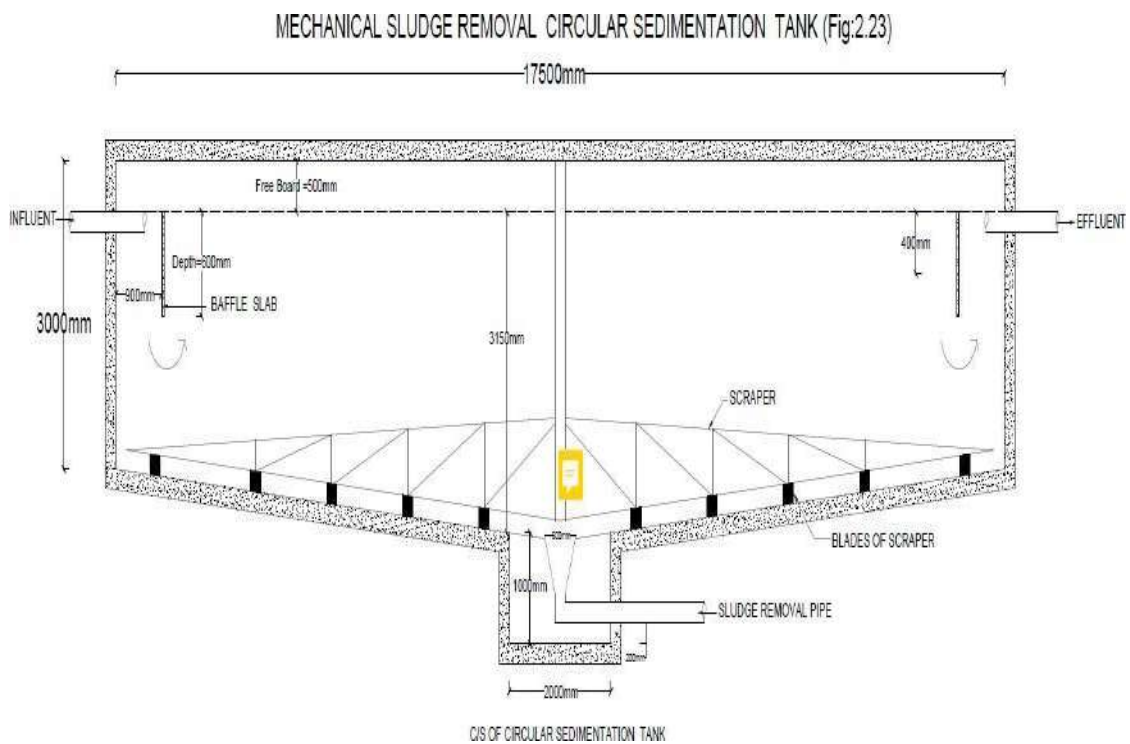

H. LAYOUT PLAN OF RAIN WATER RECHARGING AND HARVESTING SYSTEM

Exercise 2.24

Draw a layout plan of rainwater harvesting and recharging system for a (9 x 12) m area residential building leaving setback of 1.20m on all four sides as per bye laws. Show a cross section details for recharging pit.

Solution: Refer Fig. 2.24

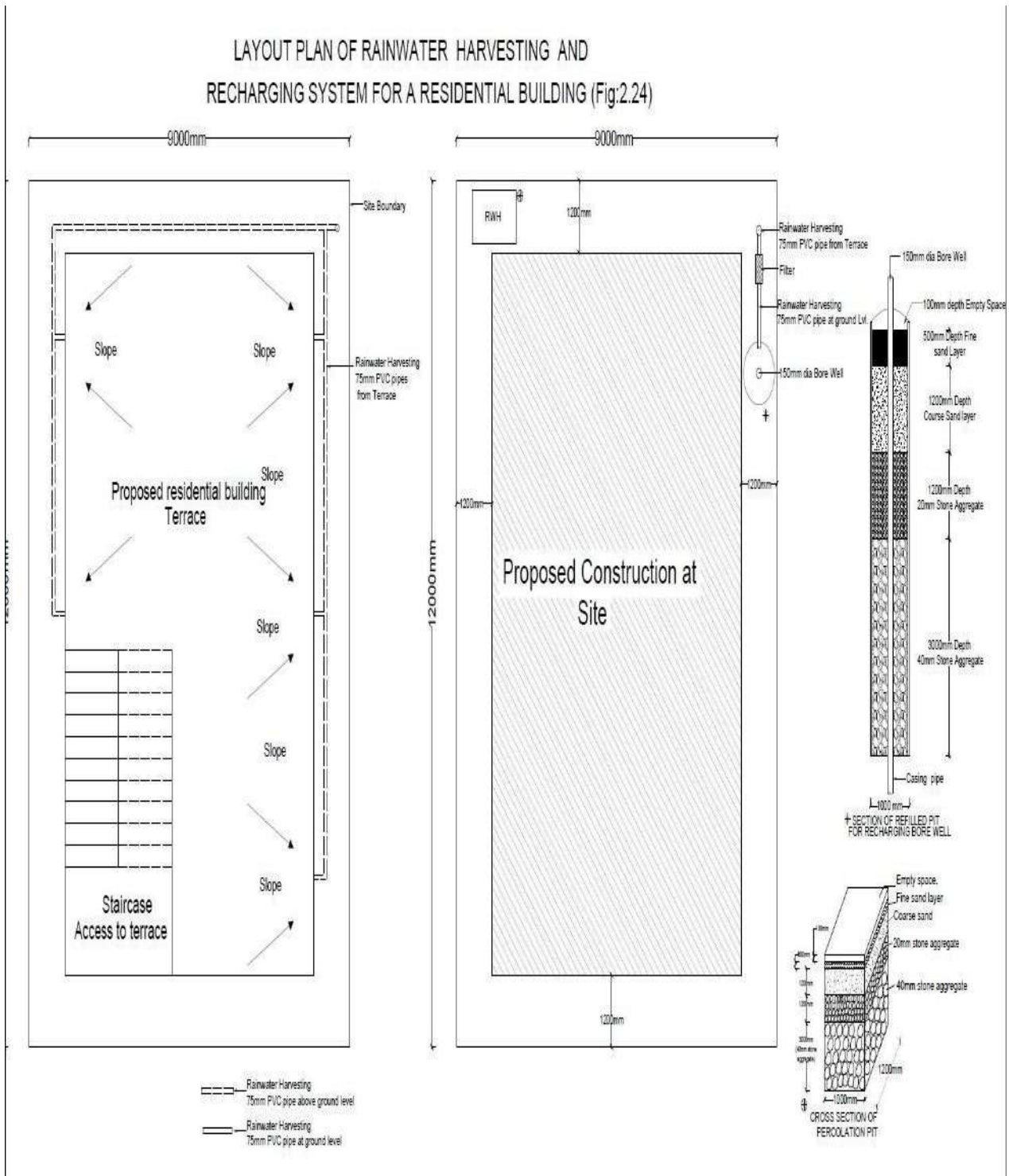

I. CROSS SECTIONAL DETAILS OF A ROAD FOR A RESIDENTIAL AREA WITH PROVISION FOR ALL SERVICES

Exercise 2.25

Draw the cross-sectional details of a road for a residential area with provision for all services.

Solution: Refer Fig. 2.25

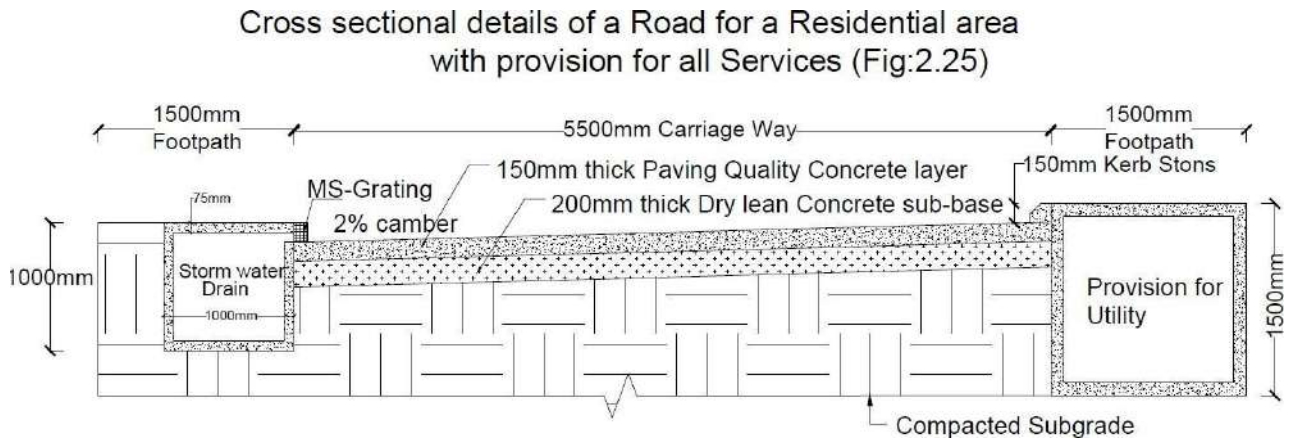

J. STEEL TRUSS (BOLTED CONNECTIONS)

Exercise 2.26

Draw the elevation of the given steel roof truss and show the connection details at joint A and E using the data given in figure.

- i. 8mm thick gusset plate
- ii. Use 2 numbers of 12φ HSFG bolts for each connection
- iii. Truss is supported on a concrete column of size (500 x 500)mm
- iv. Thickness of the base plate = 25mm
- v. Anchor bolts of 450mm length and 25φ – 8 numbers at the connection of truss and column.

Solution: Refer Fig. 2.26



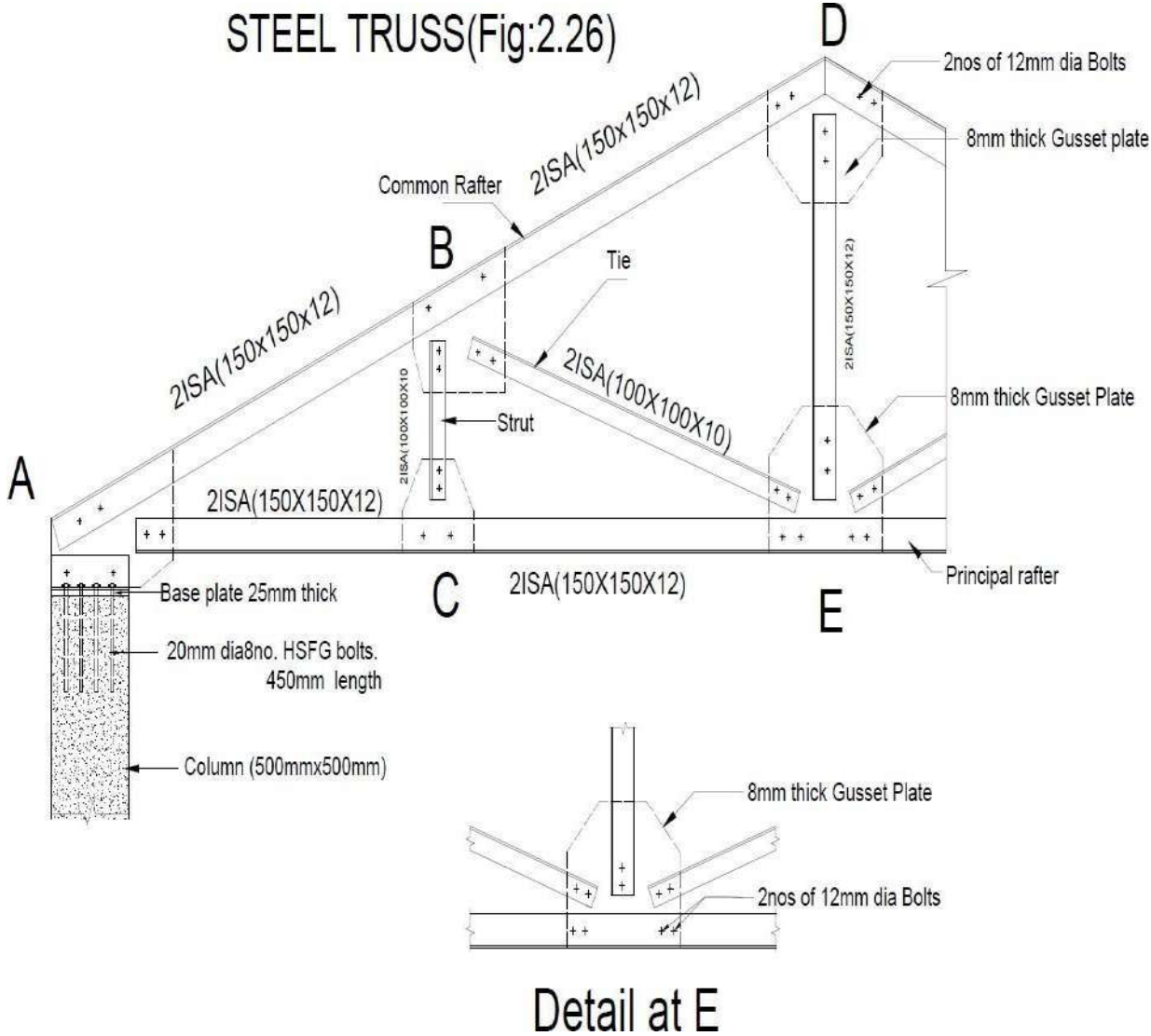

MODULE 3**BUILDING PLANNING AND DRAWING****Principles of planning**

Plan of a building is the assembling or grouping of arranging of its component parts in a systematic manner and proper order so as to form a meaningful wholesome and homogeneous body.

Planning of building depends on its;

- _ Its functional object and requirements.
- _ Its component parts, their sizes and the relationship between the different rooms.
- _ Shape of the plot and topography
- _ Climatic conditions of the place.
- _ Its location and neighbourhood
- _ Type of the buildings like single storied/ multi storied or detached/ semi- detached/ row houses.

The factors or principles which govern the theory of planning are Aspects, Prospect, Privacy, Furniture requirement, Grouping, Circulation, Sanitation, Flexibility, Elegance, Economy, Practical consideration.

Building Bye-laws

Minimum provisions designed from National Building Code by Town Planning Authorities, Urban Development Authorities and Municipalities. The building bye-laws and regulations should be enforced by proper authority to achieve following objectives.

1. They prohibit and prevent haphazard and irregular growth as ribbon development and permit disciplined and systematic growth of buildings along roads by clearly earmarking residential, commercial, industrial areas, etc.
2. They regulate the open space around the building, window area and head rooms, thereby creating conducive conditions for natural lighting and ventilation.
3. The standard dimensions for various structural members are specified which give strength and long life for the building.
4. The bye-laws regulate the planning, designing and execution of building elements.
5. The bye-laws enable the inmates to easily get access to utilities as piped water supply, electric power and connection to public sewer.
6. The growth of township is streamlined by maintaining uniform height of buildings, uniform frontage so that the abutting road is straight, gently sloping, free from blind corners and can be easily widened in future if required.

Drawing of plan, elevation and sectional elevation including electrical, plumbing and sanitary services using CAD software for following exercises:

Exercise 3.1

Draw plan, elevation and sectional elevation including electrical plumbing and sanitary services for a given line diagram of single storey residential building in figure Q.no.3.1.

Solution:

Plan – Refer Fig. 3.1.1

Sectional elevation - Refer Fig. 3.1.2

Elevation - Refer Fig. 3.1.3

Water supply and sanitary layout - Refer Fig. 3.1.4

Electrical layout - Refer Fig. 3.1.5

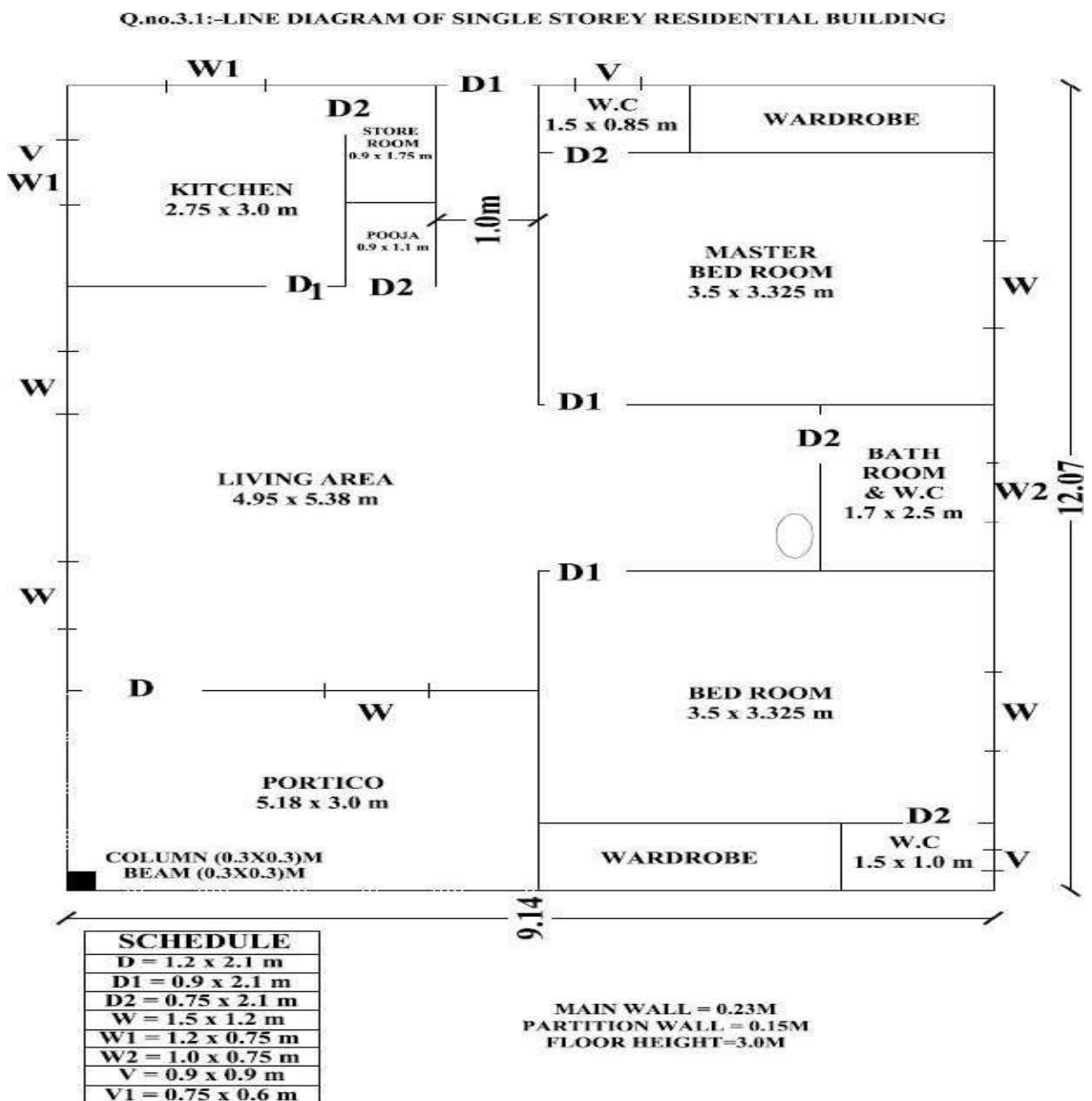

PLAN OF SINGLE STOREY RESIDENTIAL BUILDING(Fig:3.1.1)

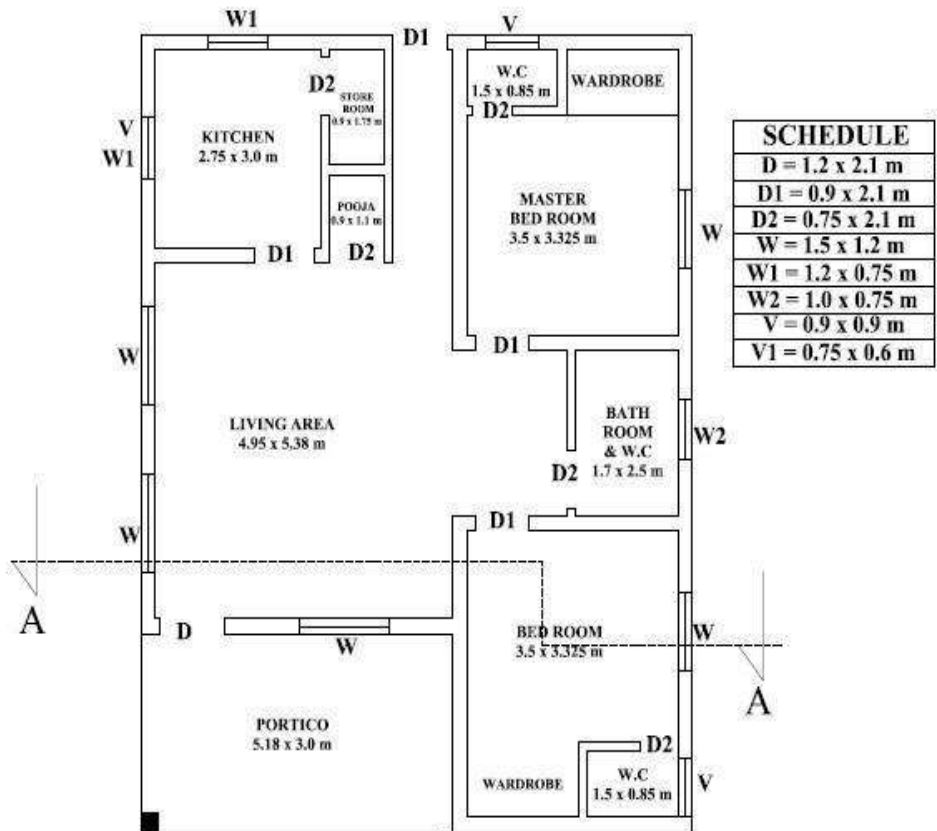

C/S OF SINGLE STOREY RESIDENTIAL BUILDING(Fig:3.1.2)

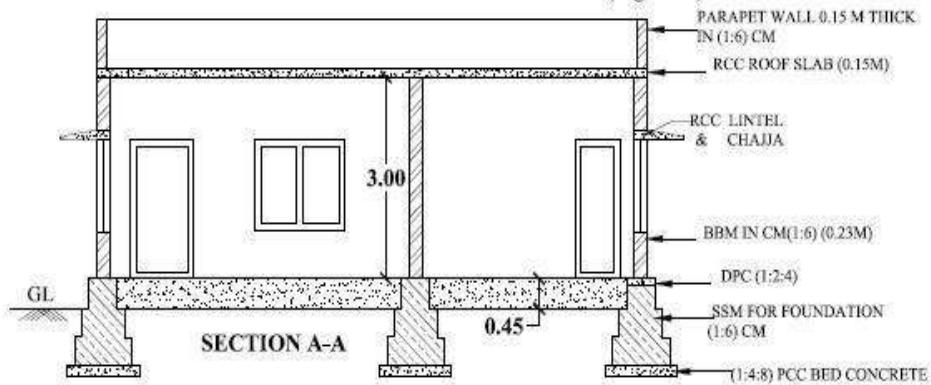

ELEVATION OF SINGLE STOREY RESIDENTIAL BUILDING(Fig:3.1.3)

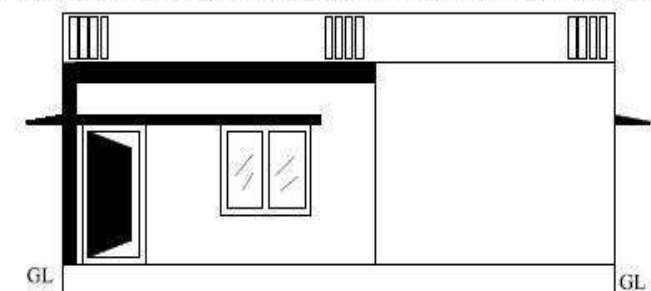

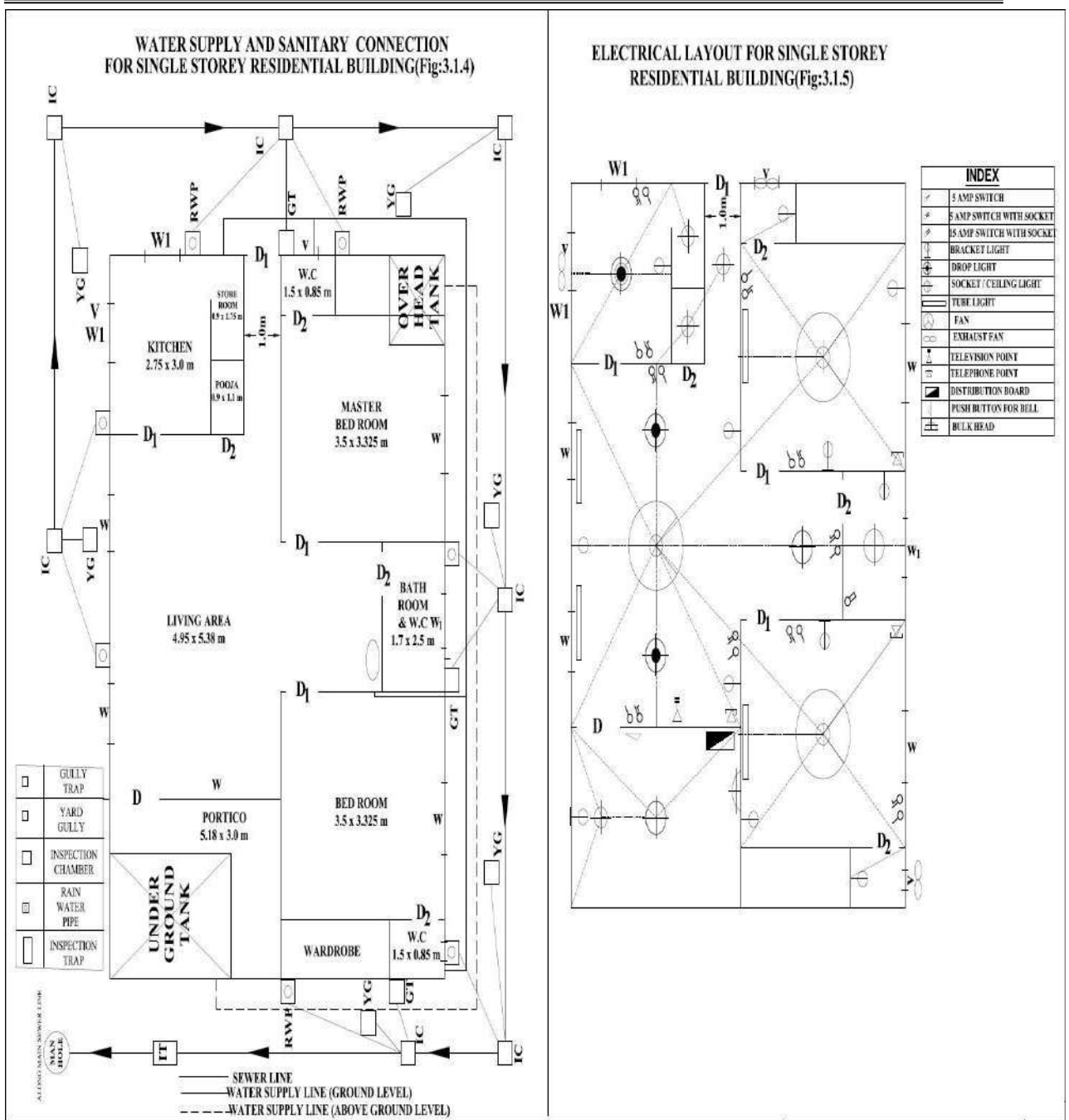

Exercise 3.2

Draw plan, elevation and sectional elevation including electrical, plumbing and sanitary services for a given line diagram of two storey residential building in figure Q.no.3.2.

Solution:

Plan – Refer Fig. 3.2.1

Sectional elevation - Refer Fig. 3.2.2

Elevation - Refer Fig. 3.2.3

Water supply and sanitary layout - Refer Fig. 3.2.4

Electrical layout - Refer Fig. 3.2.5

Q.no.(3.2):- LINE DIAGRAM OF TWO FLOORS BUILDING

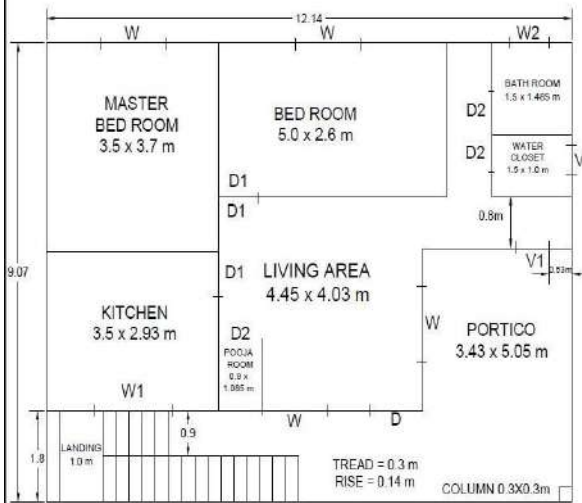

PLAN AT GROUND FLOOR

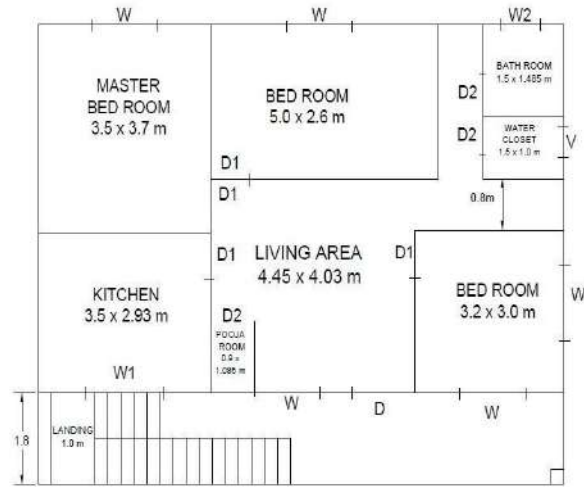

PLAN AT FIRST FLOOR

ALL LOAD BEARING WALLS OF 230mm THICK AND PARTION WALLS AS 150mm THICK
FLOOR HEIGHT=3.0M

SCHEDULE	
D	= 1.2 x 2.1 m
D1	= 0.9 x 2.1 m
D2	= 0.75 x 2.1 m
W	= 1.5 x 1.2 m
W1	= 1.8 x 0.75 m
W2	= 0.9 x 0.75 m
V	= 0.8 x 0.45 m
V1	= 0.75 x 0.6 m

TWO FLOORS BUILDING PLAN(Fig:3.2.1)

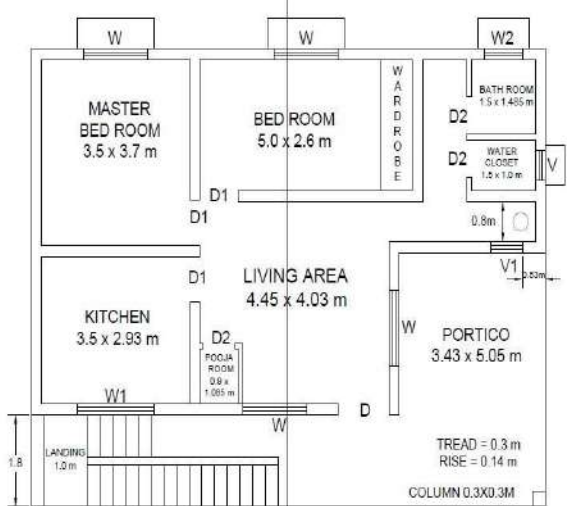

PLAN AT GROUND FLOOR

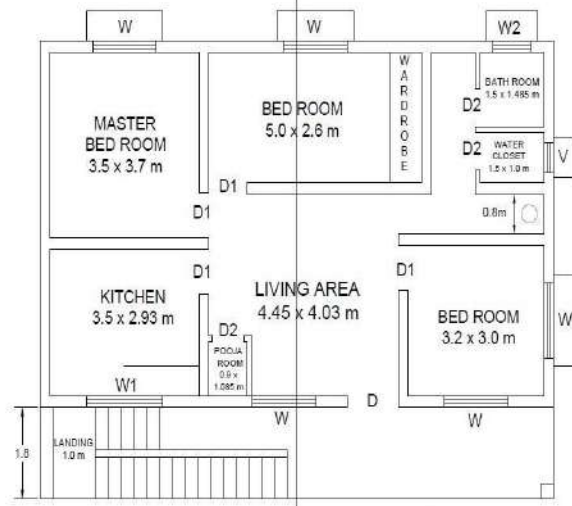

PLAN AT FIRST FLOOR

SCHEDULE	
D	= 1.2 x 2.1 m
D1	= 0.9 x 2.1 m
D2	= 0.75 x 2.1 m
W	= 1.5 x 1.2 m
W1	= 1.8 x 0.75 m
W2	= 0.9 x 0.75 m
V	= 0.6 x 0.45 m
V1	= 0.75 x 0.6 m

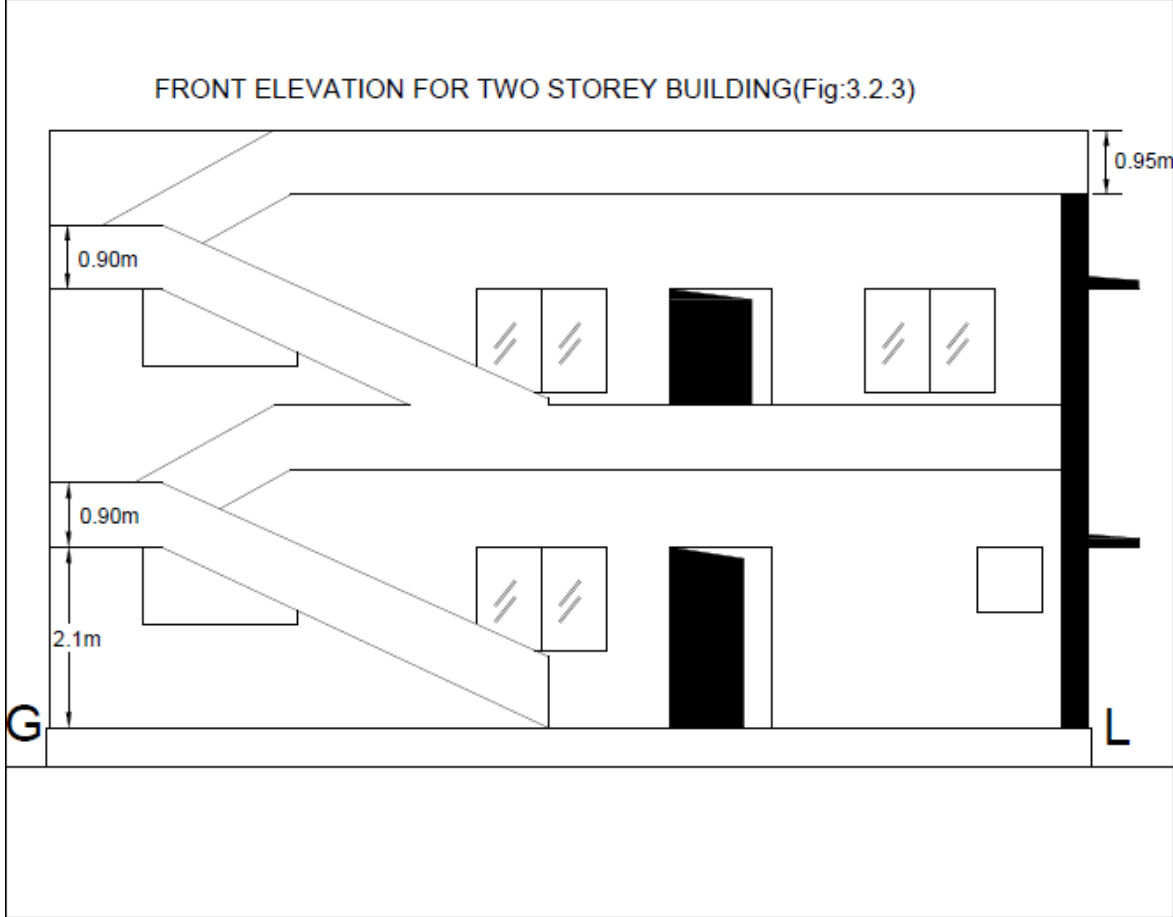
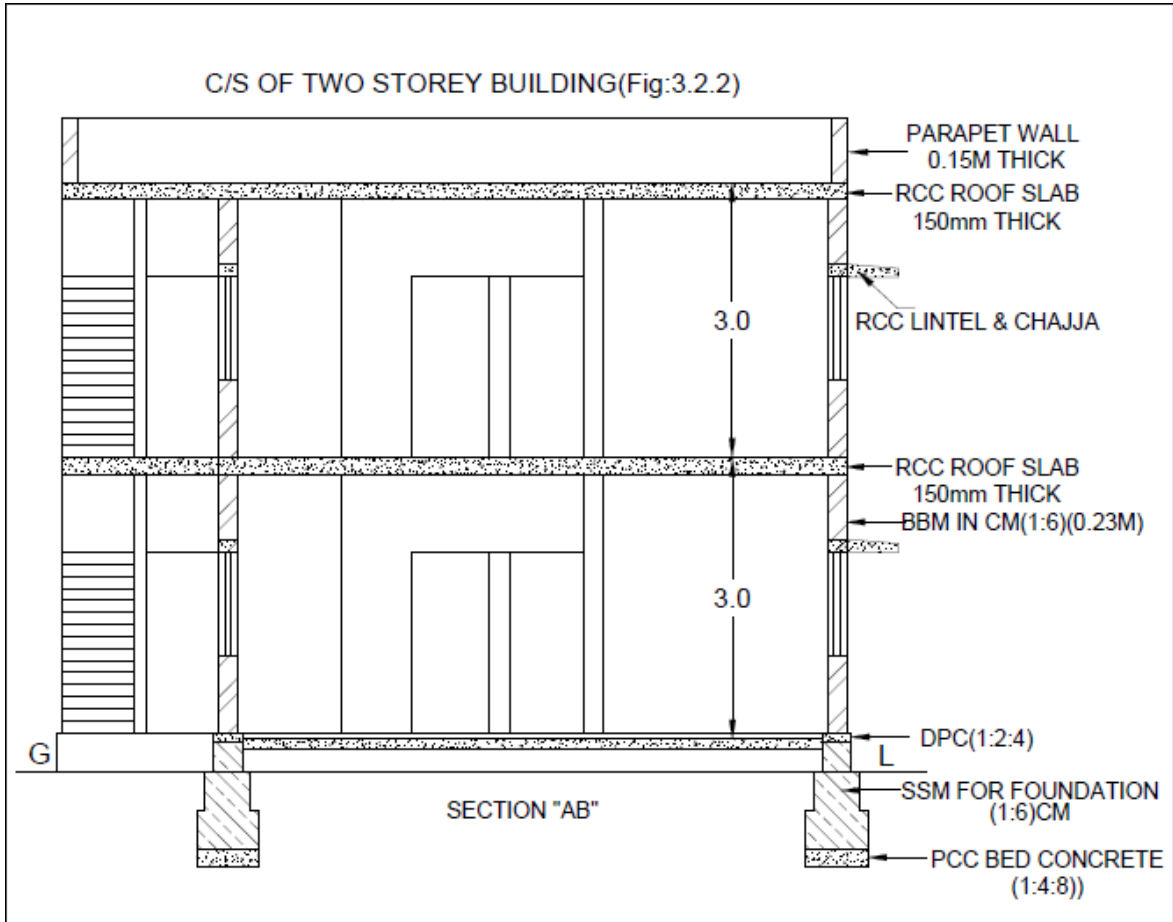

WATER SUPPLY AND SANITARY LAYOUT FOR TWO FLOORS BUILDING(Fig:3.2.4)

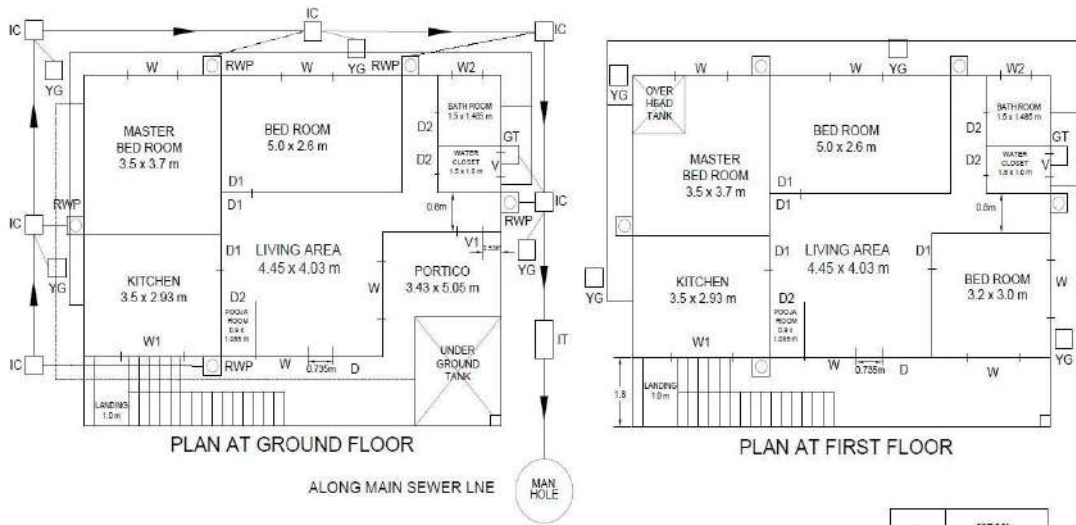

——— SEWER LINE
 ——— WATER SUPPLY LINE (GROUND LEVEL)
 - - - - - WATER SUPPLY LINE (ABOVE GROUND LEVEL)

	GULLY TRAP
	YARD GULLY
	INSPECTION CHAMBER
	RAIN WATER PIPE
	INSPECTION TRAP

ELECTRICAL LAYOUT FOR TWO FLOORS BUILDING(Fig:3.2.5)

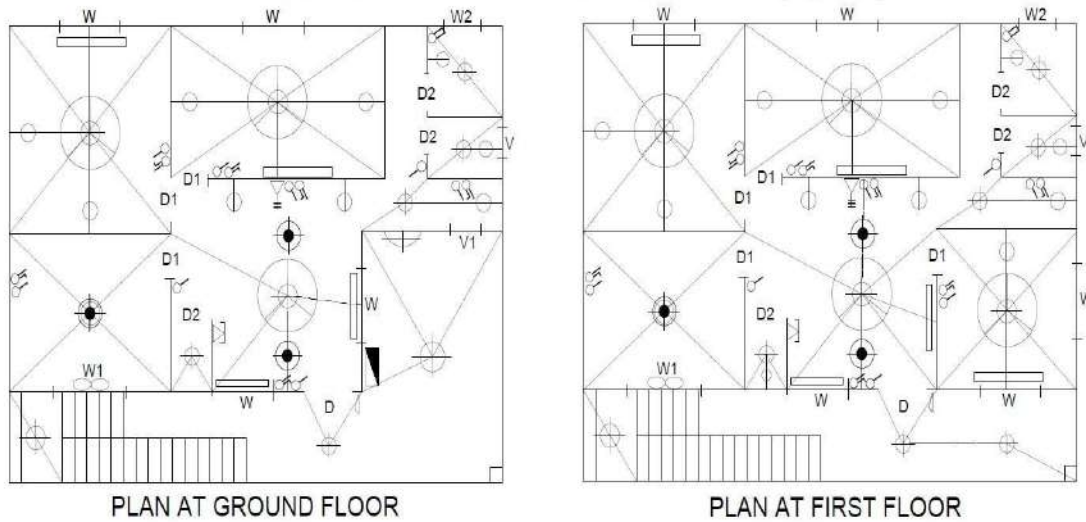

PLAN AT GROUND FLOOR

PLAN AT FIRST FLOOR

INDEX

	5 AMP SWITCH		TUBE LIGHT
	5 AMP SWITCH WITH SOCKET		FAN
	15 AMP SWITCH WITH SOCKET		EXHAUST FAN
	BRACKET LIGHT		TELEVISION POINT
	DROP LIGHT		TELEPHONE POINT
	SOCKET / CEILING LIGHT		DISTRIBUTION BOARD
	BULK HEAD		PUSH BUTTON FOR BELL

Exercise 3.3

Draw plan, elevation and sectional elevation including electrical, plumbing and sanitary services for a given line diagram of Hostel building in figure Q.no.3.3.

Solution:

Plan – Refer Fig. 3.3.1

Sectional elevation - Refer Fig. 3.3.2

Elevation - Refer Fig. 3.3.3

Water supply and sanitary layout - Refer Fig. 3.3.4

Electrical layout - Refer Fig. 3.3.5

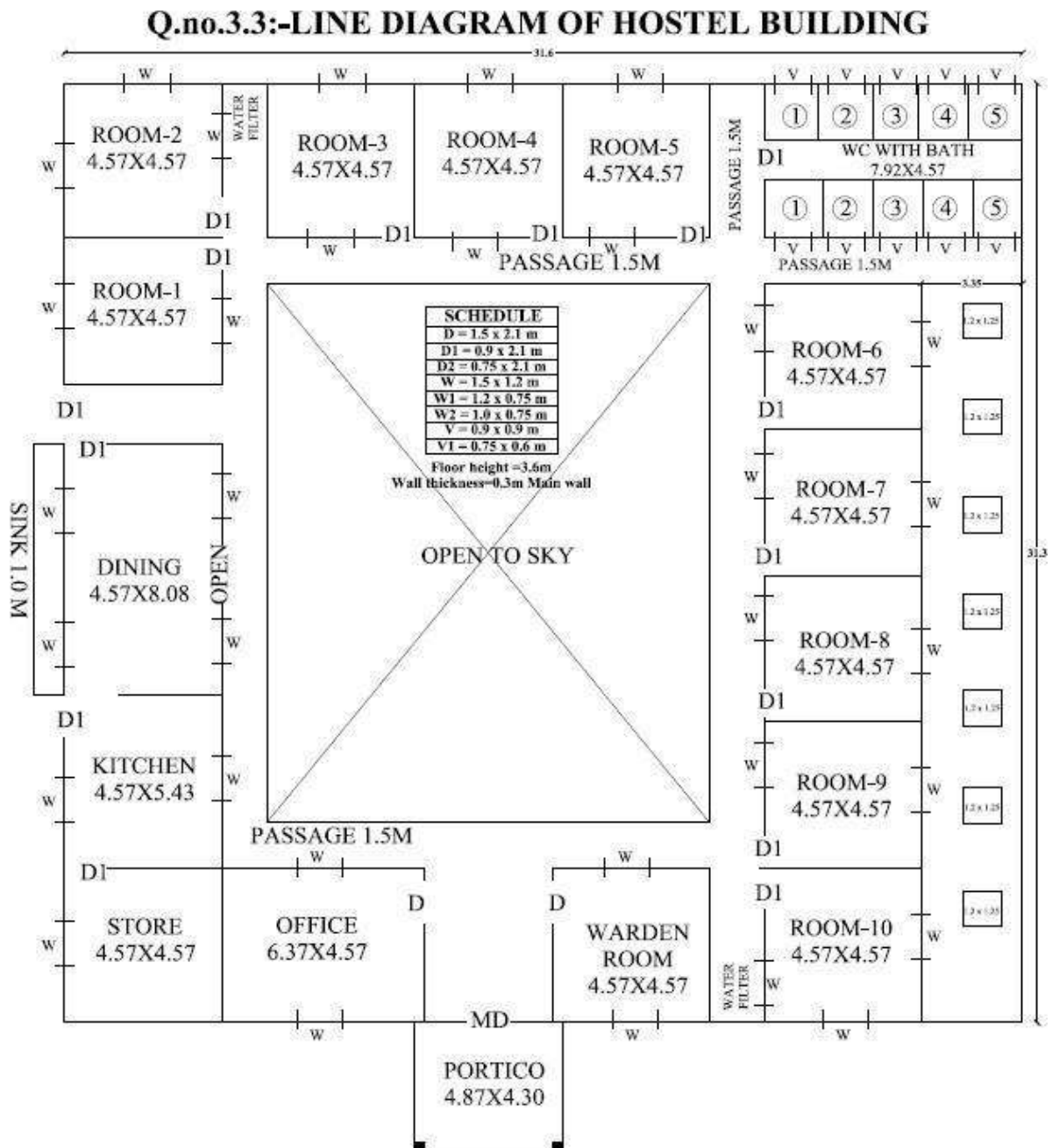

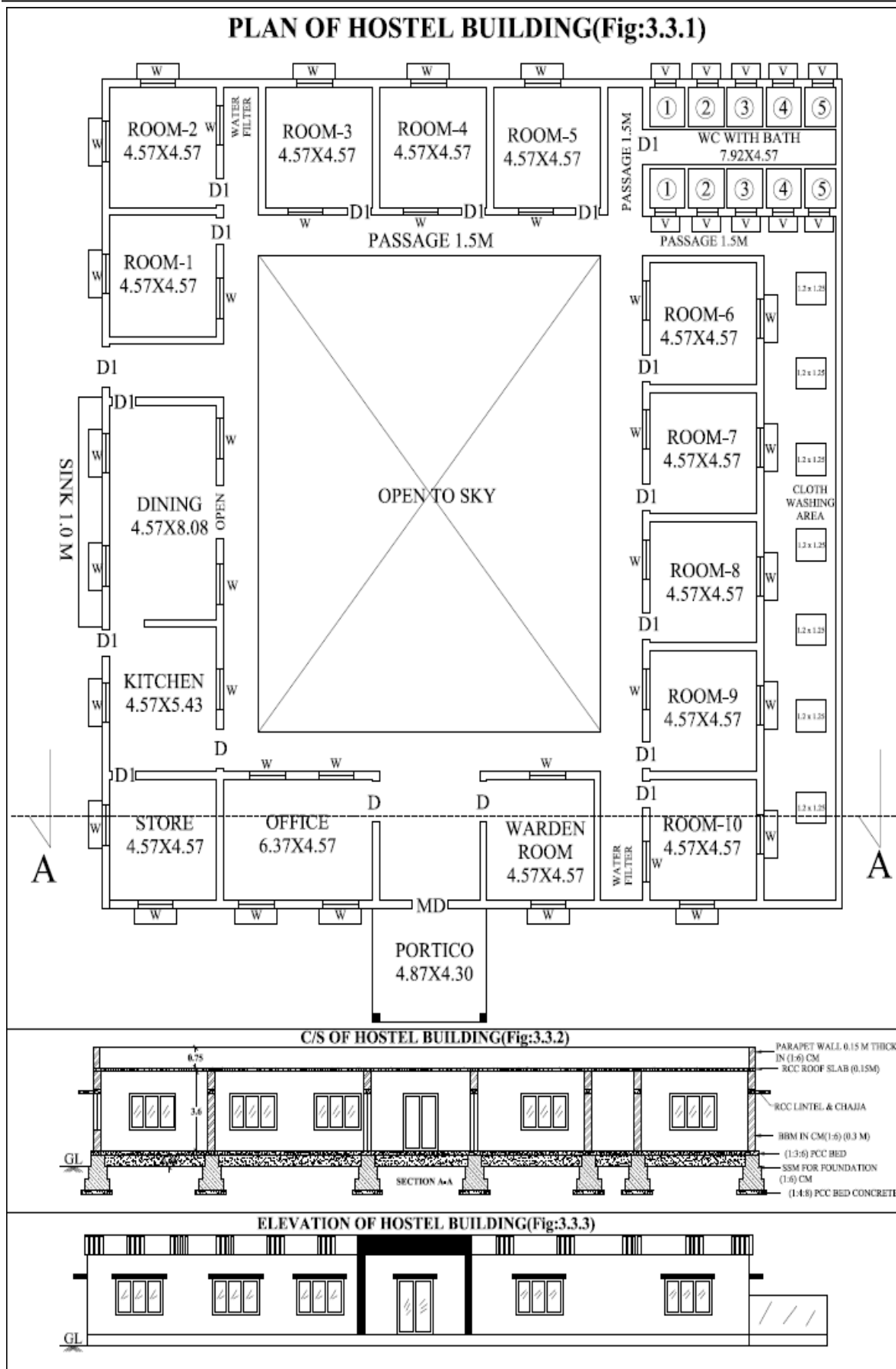

WATER SUPPLY AND SANITARY CONNECTION FOR HOSTEL BUILDING(Fig:3.3.4)

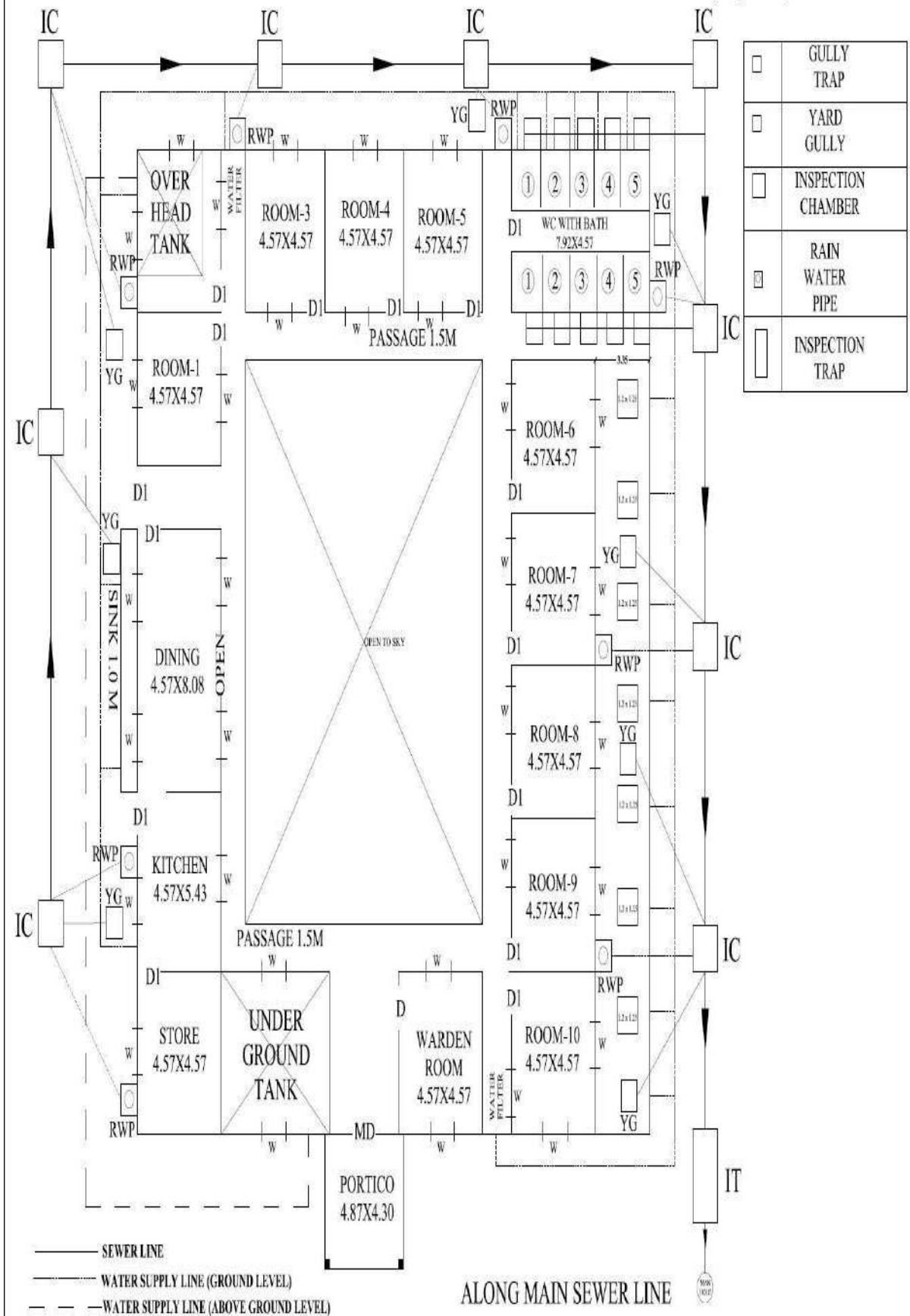

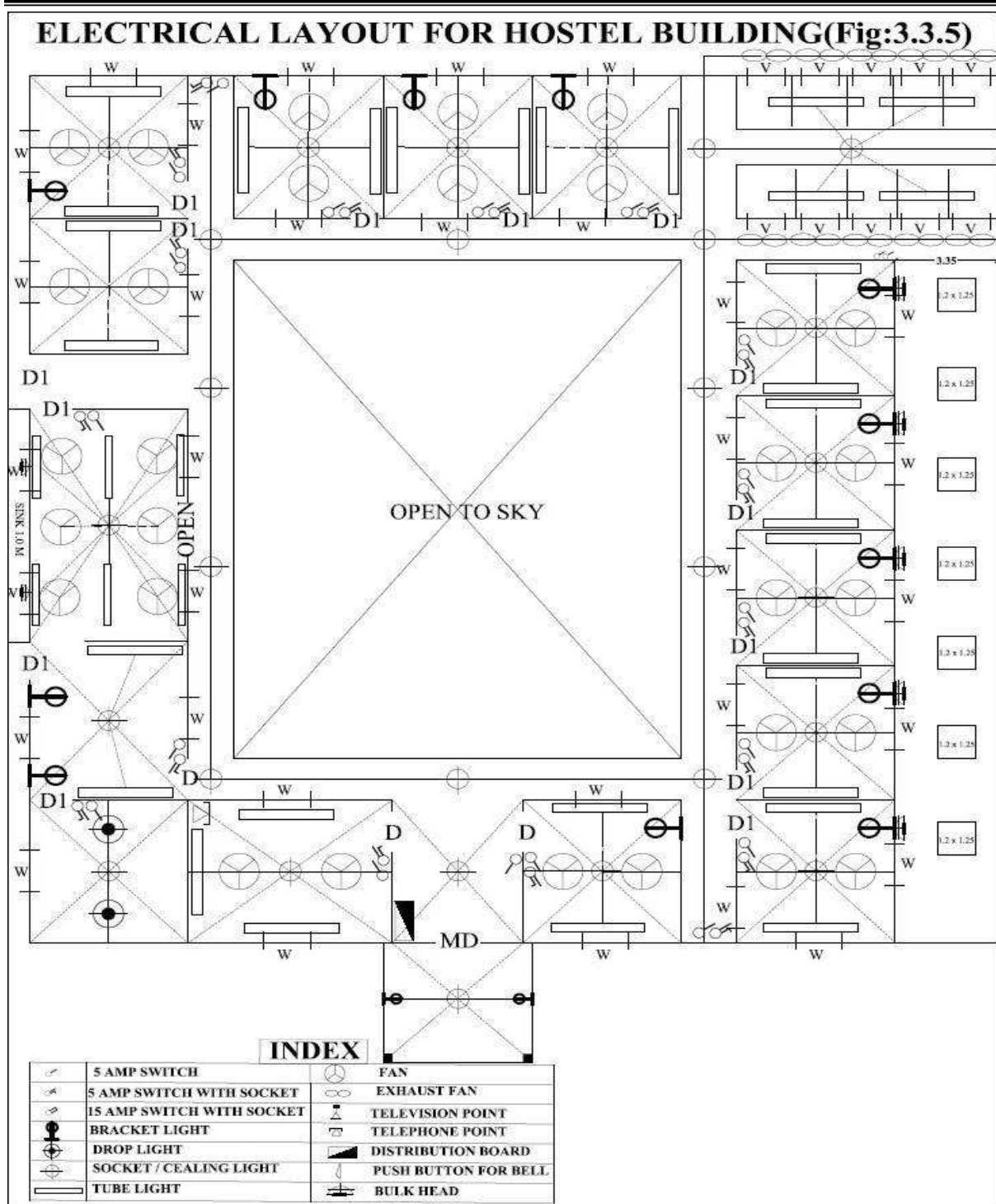

Exercise 3.4

Draw plan, elevation and sectional elevation including electrical, plumbing and sanitary services for a given line diagram of Hospital building in figure Q.no.3.4.

Solution:

Plan – Refer Fig. 3.4.1

Sectional elevation - Refer Fig. 3.4.2

Elevation - Refer Fig. 3.4.3

Water supply and sanitary layout - Refer Fig. 3.4.4

Electrical layout - Refer Fig. 3.4.5

Q.no.3.4:-LINE DIAGRAM OF HOSPITAL BUILDING

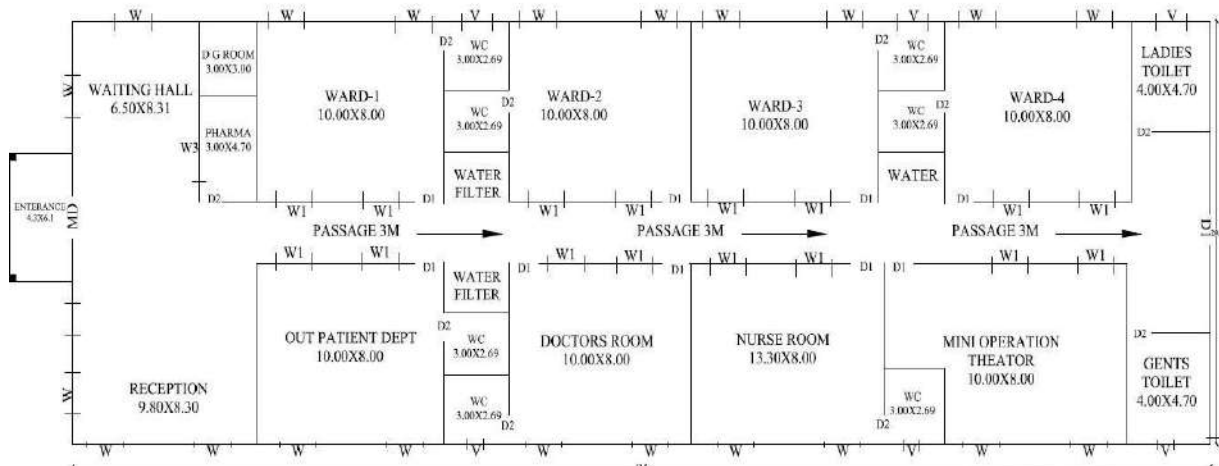

SCHEDULE	
D	= 1.5 x 2.1 m
D1	= 0.9 x 2.1 m
D2	= 0.75 x 2.1 m
W	= 1.5 x 1.2 m
W1	= 1.2 x 0.75 m
W2	= 1.0 x 0.75 m
W3	= 1.0 x 4.1 m
V	= 0.9 x 0.9 m
V1	= 0.75 x 0.6 m

Floor height=3.6 m
Wall thickness=0.3m

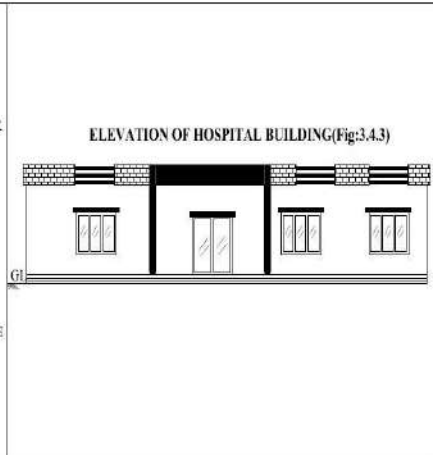
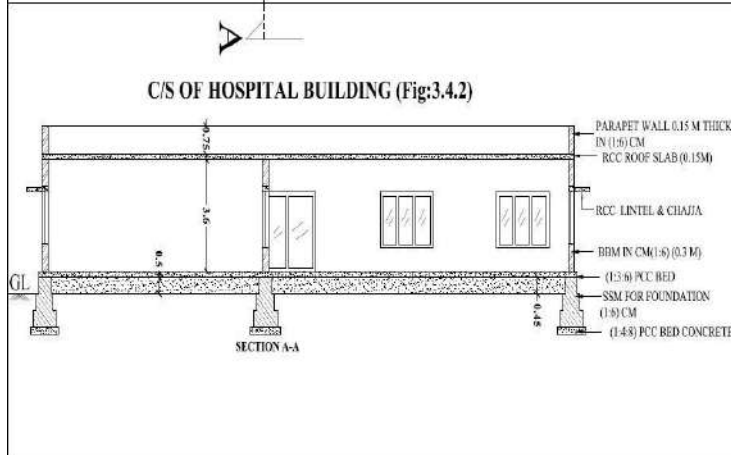
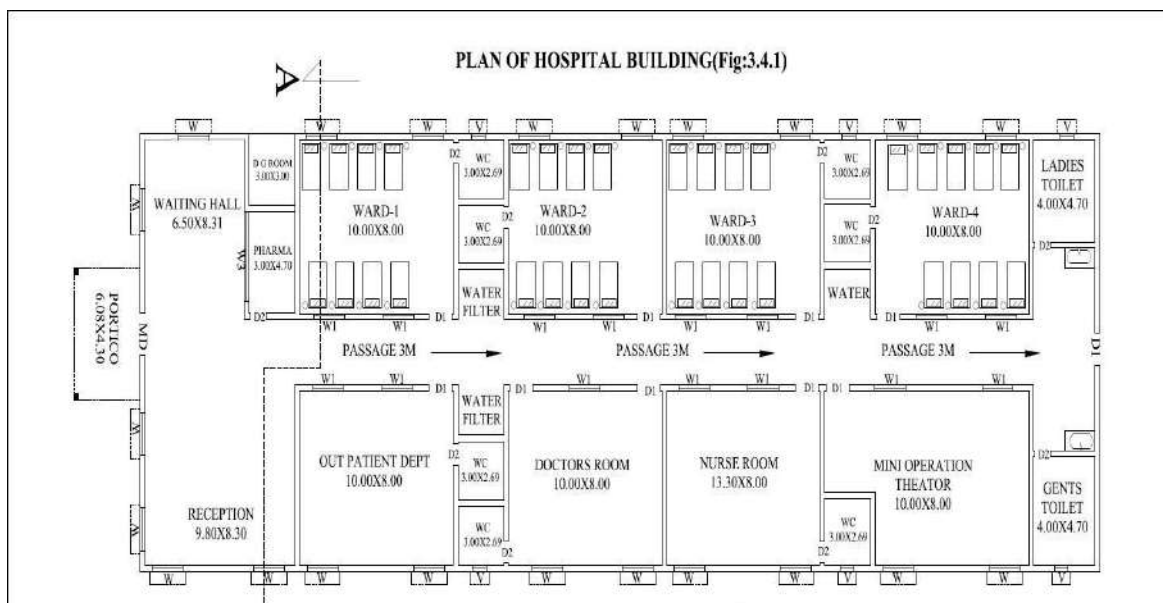

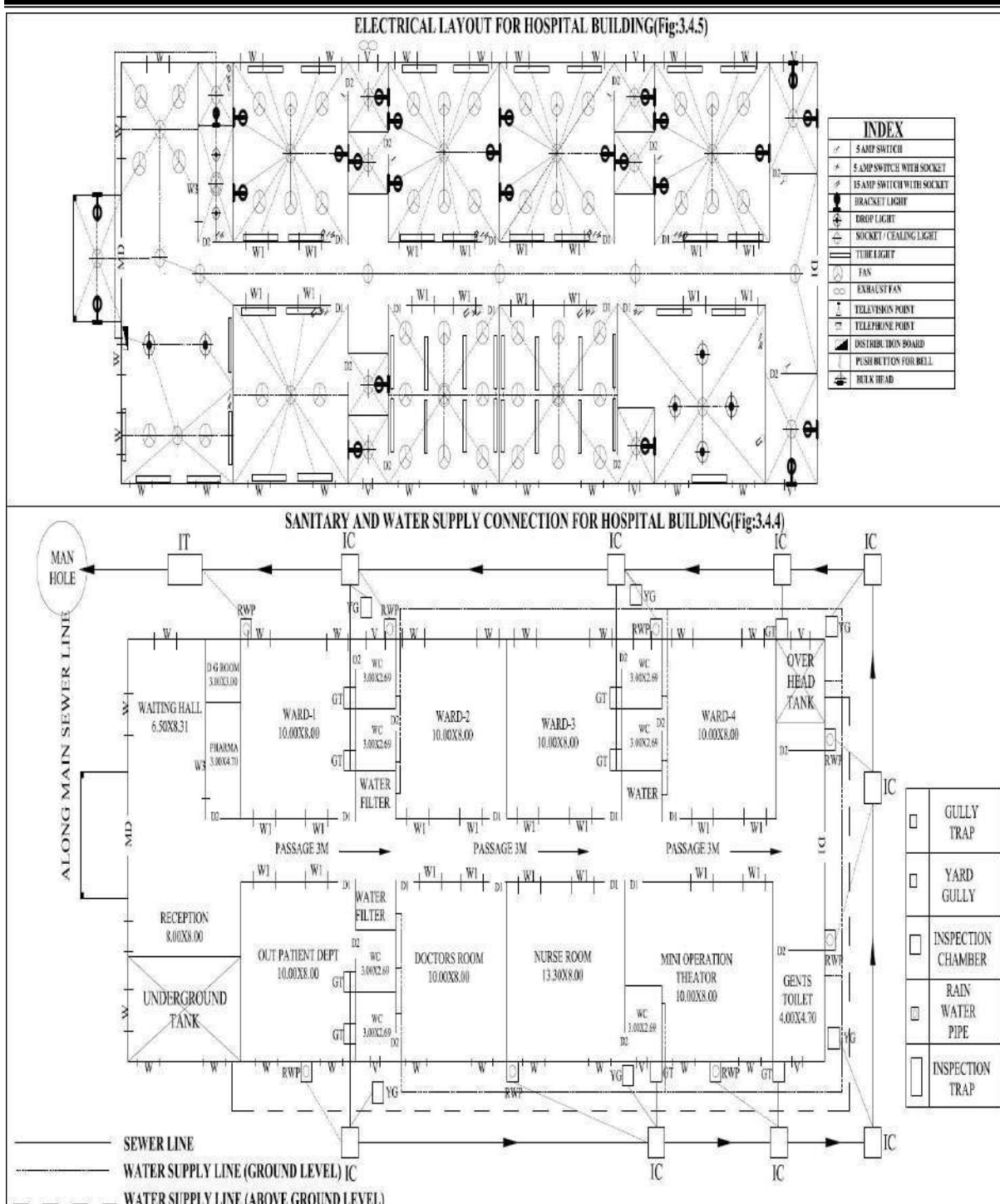

Exercise 3.5

Draw plan, elevation and sectional elevation including electrical, plumbing and sanitary services for a given line diagram of school building in figure Q.no.3.5.

Solution:

Plan – Refer Fig. 3.5.1

Sectional elevation - Refer Fig. 3.5.2

Elevation - Refer Fig. 3.5.3

Water supply and sanitary layout - Refer Fig. 3.5.4

Electrical layout - Refer Fig. 3.5.5

Q.no.3.5:-LINE DIAGRAM OF SCHOOL BUILDING

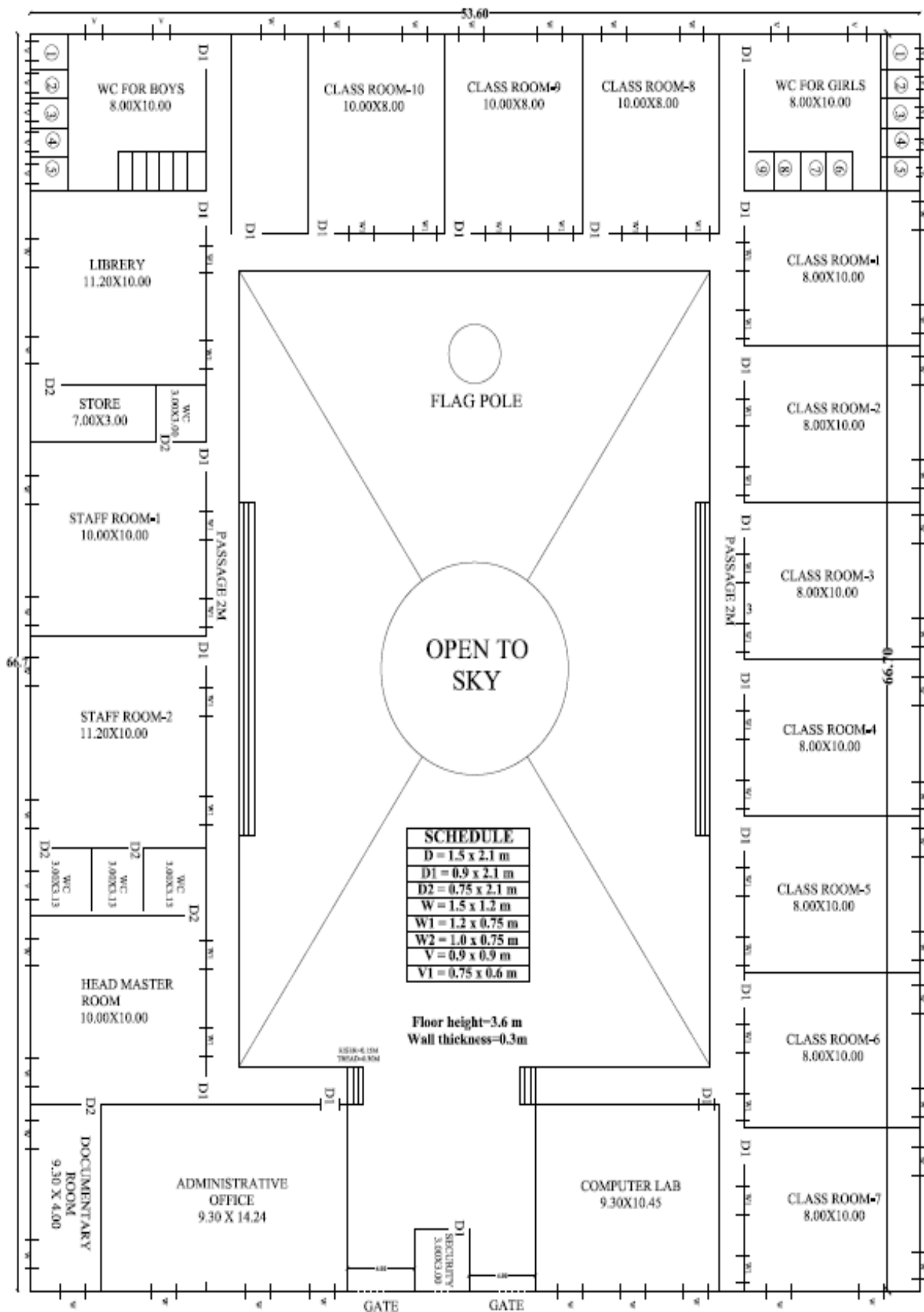

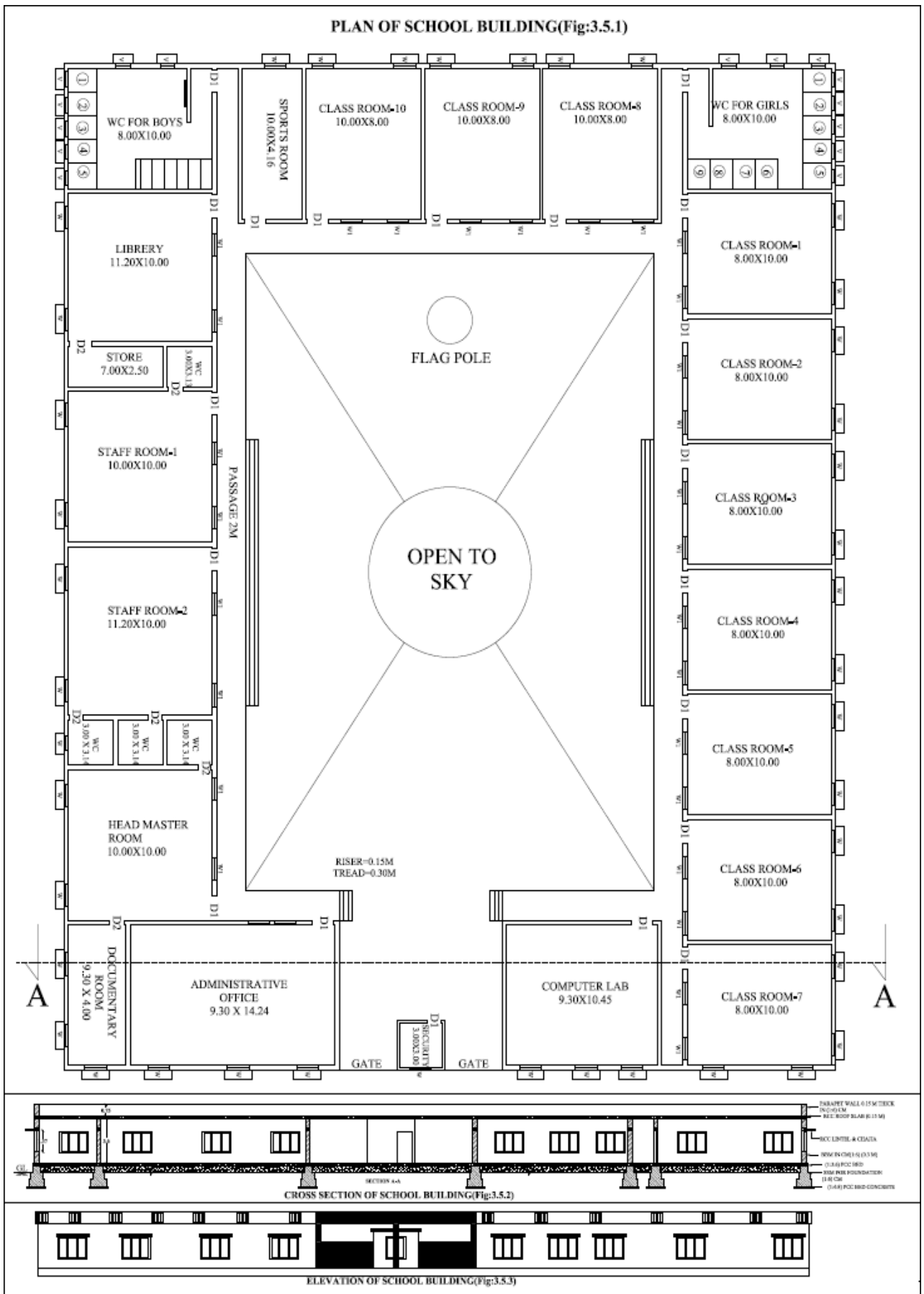

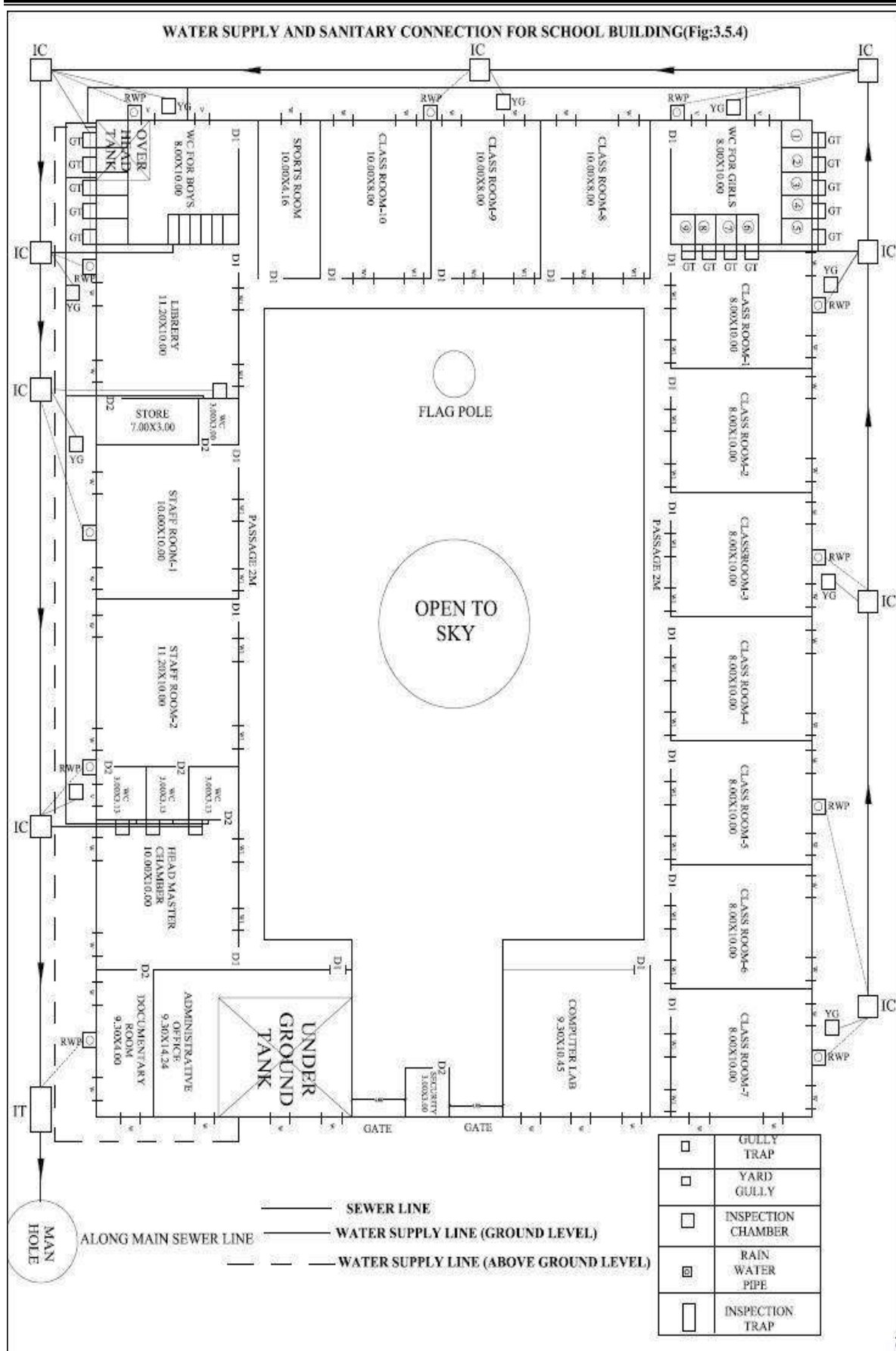

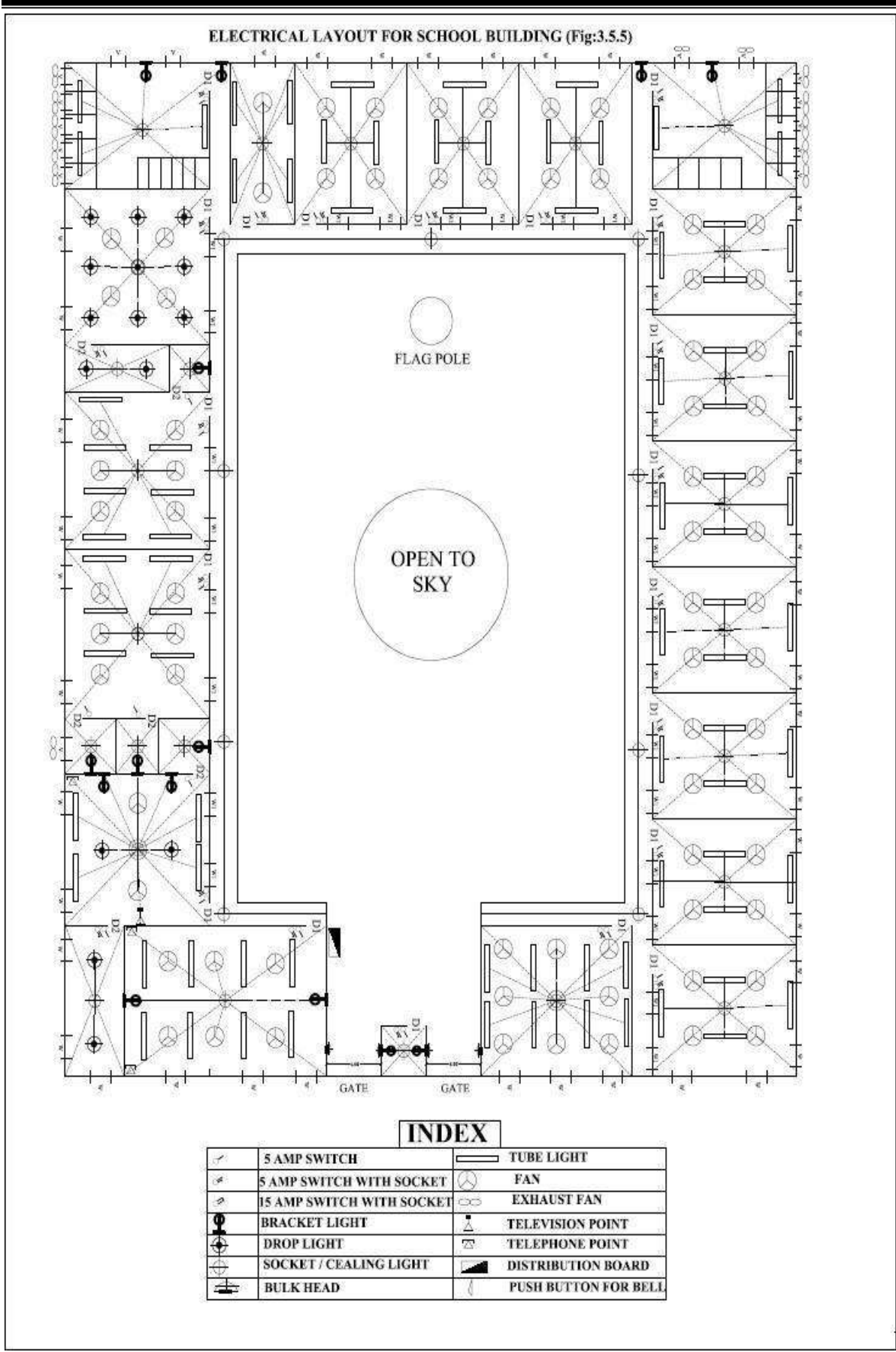

Sanction drawing:

A working plan having the following additional drawings/ details is referred as Sanction Plan

1. Location map
2. Key plan
3. Details having ward no., corporation division, details of In-charge Engineer, owner's name and present address.
4. Details of Sanctioning Authority along with the space for seal and signature of approval.
5. Details of plot area, built up area, plinth area and FAR (approved and proposed).

Mandatory instructions:

1. Basement/ Stilt floor/ GF and part of ground floor where car parking is shown is reserved for parking purpose only and shall not be converted to any other purpose.
2. Necessary ducts for telephone cables, cubicles at ground level for postal services and space for dumping garbage within the premises shall be provided.
3. Licence and approved plans shall be display in a conspicuous place of the licensed premises.
4. The applicant shall ensure that the Rainwater Harvesting Structures are provided and maintained in good condition for storage of water for non-potable purposes or recharge of ground water at all times having a minimum total capacity mentioned in the bye-laws 32(a).
5. Employment of child labour in the construction activities is strictly prohibited.

Exercise 3.6

Prepare the submission drawing (sanction drawing) of stilt with two storey residential building with access to terrace including all details and statements as per the local by- laws for a site of (9 x 12) m.

Solution: Refer Fig. 3.6

