

HJAJSERI GURUDEVI

# S. J. C. Institute of Technology, Chickballapur

CALENDAR OF EVENTS FOR THE ACADEMIC YEAR 2019-2020 (ODD SEMESTER) FOR BE, MBA & M.Tech



Accredited by NAAC & Certified by ISO 9001-2015

Week No.	Month	Week Days							Number of Working Days	EVENTS
		Mon	Tue	Wed	Thu	Fri	Sat	Sun		
1.	JULY	22	23	24	25	26	27	28	6	26 <sup>th</sup> July - Commencement of 3 <sup>rd</sup> Semester MTech
2.	JULY & AUG	29	30	31	1	2	3	4	6	29 <sup>th</sup> July - Commencement of 3 <sup>rd</sup> , 5 <sup>th</sup> & 7 <sup>th</sup> Semester BE Classes, 31 <sup>st</sup> July - HODs meeting 1 <sup>st</sup> August - Commencement of 1 <sup>st</sup> Semester BE Classes, 3 <sup>rd</sup> August - 7 <sup>th</sup> Semester Project (Phase - 1) First Review
3.	AUG	5	6	7	8	9	10	11	6	7 <sup>th</sup> August - Proctor Meeting, 8 <sup>th</sup> August - Commencement of 3 <sup>rd</sup> Semester MBA Classes 10 <sup>th</sup> August - 7 <sup>th</sup> Semester Project (Phase - 1) First Review
4.	AUG	12	13	14	15	16	17	18	4	12 <sup>th</sup> August - Bakrid, 15 <sup>th</sup> August - Independence Day, 13 <sup>th</sup> August - Announcement of Shortage of Attendance
5.	AUG	19	20	21	22	23	24	25	6	24 <sup>th</sup> August - Sports & NSS Activity
6.	AUG & SEP	26	27	28	29	30	31	1	6	28 <sup>th</sup> August - HODs Meeting
7.	SEP	2	3	4	5	6	7	8	5	2 <sup>nd</sup> September - Vinayaka Chaturthi, 3 <sup>rd</sup> September - Announcement of Attendance 3 <sup>rd</sup> to 7 <sup>th</sup> September - Tutorial-1, 7 <sup>th</sup> October - 7 <sup>th</sup> Semester Project (Phase - 1) Second Review
8.	SEP	9	10	11	12	13	14	15	5	10 <sup>th</sup> September - Maharam Last Day, 12 <sup>th</sup> , 13 <sup>th</sup> & 14 <sup>th</sup> September - Test 1
9.	SEP	16	17	18	19	20	21	22	6	19 <sup>th</sup> September - Submission of Test - 1 IA Marks, 20 <sup>th</sup> September - Test 1 Progress Report Dispatch
10.	SEP	23	24	25	26	27	28	29	5	21 <sup>st</sup> September - 7 <sup>th</sup> Semester Project (Phase - 1) Second Review, 21 <sup>st</sup> September - Sports & NSS Activity
11.	SEP & OCT	30	1	2	3	4	5	6	5	25 <sup>th</sup> September - Class Teachers Meeting & Proctor Meeting, 28 <sup>th</sup> September - Mahalaya Annavasya
12.	OCT	7	8	9	10	11	12	13	4	1 <sup>st</sup> October - Announcement of Attendance, 2 <sup>nd</sup> October - Mahatma Gandhi Jayanthi
13.	OCT	14	15	16	17	18	19	20	6	7 <sup>th</sup> October - Ayudha Pooja, 8 <sup>th</sup> October - Vijayadashami, 9 <sup>th</sup> September - HODs Meeting, 9 <sup>th</sup> to 12 <sup>th</sup> October - Tutorial - 2 13 <sup>th</sup> October - Maharshi Valmiki Jayanthi
14.	OCT	21	22	23	24	25	26	27	6	17 <sup>th</sup> , 18 <sup>th</sup> & 19 <sup>th</sup> October - Test 2, ISO Internal Audit
15.	OCT & NOV	28	29	30	31	1	2	3	4	24 <sup>th</sup> October - Submission of IA Marks, 25 <sup>th</sup> October - Test 2 Progress Report Dispatch 26 <sup>th</sup> October - 7 <sup>th</sup> Semester Project Phase - 1 Third Review, 26 <sup>th</sup> October - Sports & NSS Activity
16.	NOV	4	5	6	7	8	9	10	5	29 <sup>th</sup> October - Balipadyami & Deepavali, 30 <sup>th</sup> October - HODs, Class Teachers Meeting, and Proctor Meeting
17.	NOV	11	12	13	14	15	16	17	5	1 <sup>st</sup> November - Kannada Rajyotsava, 2 <sup>nd</sup> November - 7 <sup>th</sup> Semester Project Phase - 1 Third Review
18.	NOV	18	19	20	21	22	23	24	6	4 <sup>th</sup> November - Announcement of Attendance, 10 <sup>th</sup> November - Ed Milad
19.	NOV	25	26	27	28	29	30	1	6	11 <sup>th</sup> to 16 <sup>th</sup> - Tutorial 3, 13 <sup>th</sup> November - HODs Meeting, 15 <sup>th</sup> November - Kanaka Dasa Jayanthi 21 <sup>st</sup> , 22 <sup>nd</sup> & 23 <sup>rd</sup> November - Test 3, 27 <sup>th</sup> November - Submission of IA Marks
20.	DEC	2	3	4	5	6	7	8	6	29 <sup>th</sup> - Last Working Day for 1 <sup>st</sup> Semester BE Classes, 30 <sup>th</sup> November - Last Working Day for 3 <sup>rd</sup> , 5 <sup>th</sup> & 7 <sup>th</sup> Semester BE Students
21.	DEC	9	10	11	12	13	14	15	6	3 <sup>rd</sup> December - Commencement of Practical Examinations for 1 <sup>st</sup> , 3 <sup>rd</sup> , 5 <sup>th</sup> & 7 <sup>th</sup> Semester BE Students
22.	DEC	16	17	18	19	20	21	22	6	5 <sup>th</sup> December - Last Working Day for 3 <sup>rd</sup> Semester MBA Classes
23.	DEC	23	24	25	26	27	28	29	5	9 <sup>th</sup> December - Commencement Theory Examination for 3 <sup>rd</sup> Semester MBA Students 16 <sup>th</sup> December - Commencement Theory Examination for 1 <sup>st</sup> , 3 <sup>rd</sup> , 5 <sup>th</sup> & 7 <sup>th</sup> Semester BE Students 27 <sup>th</sup> December - Commencement Theory Examination for 3 <sup>rd</sup> Semester MTech Students

27<sup>th</sup> January 2020 - Commencement of 2<sup>nd</sup> Semester BE, 4<sup>th</sup> Semester MBA & 4<sup>th</sup> Semester MTech classes // 10<sup>th</sup> February 2020 Commencement of 4<sup>th</sup>, 6<sup>th</sup> & 8<sup>th</sup> Semester BE classes

Note: VII Semester B. E students shall have to undergo Internship for a period of four Weeks

Note: I Semester B. E Students shall compulsorily undergo Induction Program for a period of 3 Weeks (two phases) as per the schedule given by VTU. First phase 11 days in first semester and second phase 10 days in second semester

## VISION

SJCIT is Committed to Quality Education, Training and Research

## MISSION

- ❖ Augmenting the supply of Competent Engineers and Managers
- ❖ Building Engineers and managers with Value, Vision and Versatility
- ❖ Developing and Disseminating New Knowledge and Insights

**Dr. G. V Gnanendra Reddy**  
Academic In-charge

**Dr. K.M. Ravi Kumar**  
Principal

HOLIDAYS: Red

## Academic Calendar of VTU, Belagavi for ODD Semester of 2019-2020 (Jul 2019 – Jan 2020)

	I Sem B. E. / B. Tech. / B. Arch. (Tentative)	III, V & VII Sem B. E. / B. Tech. III, V, VII & IX Sem B. Arch.	III & V Sem MCA	III Sem MBA	III Sem M. Tech.	III Sem M. Arch.
Commencement of ODD Semester	01.08.2019	29.07.2019	29.07.2019	08.08.2019	26.08.2019	08.09.2019
Last Working day of ODD Semester	29.11.2019	30.11.2019	30.11.2019	05.12.2019	23.12.2019	06.01.2020
Practical Examinations	03.12.2019 To 13.12.2019	03.12.2019 To 13.12.2019	03.12.2019 To 07.12.2019	-	-	-
Theory Examinations	16.12.2019 To 04.01.2020	16.12.2019 To 07.02.2020	09.12.2019 To 28.12.2019	09.12.2019 To 04.01.2020	27.12.2019 To 10.01.2020	08.01.2020 To 22.01.2020
Internship Viva-Voce	-	-	-	-	12.01.2020 To 19.01.2020	-
Professional training / Organization study	-	-	-	-	-	-
Commencement of EVEN Semester	27.01.2020	19.02.2020	27.01.2020	27.01.2020	27.01.2020	01.02.2020

### NOTE

- VII Semester B. E. / B. Tech students shall have to undergo Internship for a period of four Weeks.
  - I Semester B. E. / B. Tech / B. Arch Students shall compulsorily undergo Induction Program for a period of 3 Weeks (two phases) as per the schedule given by VTU.  
First phase : 1 days in first semester and second phase 10 days in second semester.
1. College Time Table shall be arranged for five and a half week days and planned to accommodate EDUSAT transmission slots, the schedule of which will be notified separately.
  2. The faculty/staff shall be available to undertake any work assigned by the university.
  3. If any of the above date is declared to be a holiday then the corresponding event will come into effect on the next working day.
  4. Notification regarding Calendar of Events relating to the conduct of University Examination will be issued by the Registrar (Evaluation) from time to time.

  
 REGISTRAR

Week No	Month	Week Days							Events
		Mon	Tue	Wed	Thu	Fri	Sat	Sun	
1	Jul/Aug	29	30	31	1	2	3	4	29 <sup>th</sup> July Commencement of III, V, VII Sem B.E. Classes
2	Aug	5	6	7	8	9	10	11	7 <sup>th</sup> Sept. - 7th Sem Project Phase-I First Review
3	Aug	12	13	14	15	16	17	18	12 <sup>th</sup> Aug. Bakrid., 13 <sup>th</sup> Aug. Announcement of Shortage of Attendance, 15 <sup>th</sup> Aug Independence Day 17 Aug 7 <sup>th</sup> Sem Project Phase-I First Review
4	Aug	19	20	21	22	23	24	25	21 <sup>st</sup> Aug Dept. Meeting
5	Aug/Sept	26	27	28	29	30	31	1	28 <sup>th</sup> Aug Dept Meeting, 30 <sup>th</sup> Aug. Submission of Attendance Register for attendances,
6	Sept	3	4	5	6	7	8	9	2 <sup>nd</sup> Sept. Vinayaka Chaturthi, 3 <sup>rd</sup> Sept. Attendance Registers submission for HOD's Signature 3 <sup>rd</sup> Sept Announcement of Attendance 3 <sup>rd</sup> to 7 <sup>th</sup> Sept. Tutorials-I 7 <sup>th</sup> Sept. - 7th Sem Project Phase-I Second Review
7	Sept	9	10	11	12	13	14	15	10 <sup>th</sup> Sept. Moharam Last Day 12 <sup>th</sup> , 13 & 14 <sup>th</sup> Sept Test-I
8	Sept	16	17	18	19	20	21	22	19 <sup>th</sup> Sept. Submission of Test-I IA Marks, 20 <sup>th</sup> Septembe- Test I Progress Report Dispatch 16 <sup>th</sup> Sept. Guest lecture 21 <sup>st</sup> Sept. 7th Sem Project Phase I Second Review 19 <sup>th</sup> to 20 <sup>th</sup> Sept. Industrial Visit
9	Sept	23	24	25	26	27	28	29	28 <sup>th</sup> Sept. Mahalya Amavasya, 25 <sup>th</sup> Sept. Last date for Proctor Book Entry, 25 <sup>th</sup> Sept Class Teacher's Meeting, 25 <sup>th</sup> Sept. Dept. Meeting, 29 <sup>th</sup> Sept. Submission of Attendance Register for attendances,
10	Sept/Oct	30	1	2	3	4	5	6	1 <sup>st</sup> Oct. Attendance Registers submission for HOD's Signature, 1 <sup>st</sup> Oct. Announcement of Attendance, 2 <sup>nd</sup> Oct. Mahatma Gandhi Jayanthi
11	Oct	7	8	9	10	11	12	13	7 <sup>th</sup> Oct. Ayudha Pooja, 8 <sup>th</sup> Oct. Vijayadasarini, 9 <sup>th</sup> to 12 <sup>th</sup> Oct. 3 <sup>rd</sup> to 6 <sup>th</sup> Tutorials-II, 13 <sup>th</sup> Oct. Maharashtra Valmiki Jayanthi
12	Oct	14	15	16	17	18	19	20	17 <sup>th</sup> , 18 <sup>th</sup> & 19 <sup>th</sup> Oct - Test-II / ISO Internal Audit
13	Oct	21	22	23	24	25	26	27	24 <sup>th</sup> Submission of IA Marks, 23 <sup>rd</sup> Oct. Last date for Proctor Book Entry, 25 <sup>th</sup> Oct. Test II Progress Report dispatch 23 <sup>rd</sup> October Dept. Meeting, 26 <sup>th</sup> Oct. 7th Sem Project Phase-I Third Review
14	Oct/Nov	28	29	30	31	1	2	3	29 <sup>th</sup> October Bahupadmi & Deepavali, 1 <sup>st</sup> Nov. Kannada Rajyotsava, 2 <sup>nd</sup> Nov. Attendance Registers submission for HOD's Signature, 30 <sup>th</sup> Oct. Submission of Attendance Register for attendances, 30 <sup>th</sup> Oct. HOD S & Class Teachers Meeting,
15	Nov	4	5	6	7	8	9	10	4 <sup>th</sup> Nov. Announcement of Attendance, 10 <sup>th</sup> Nov. Ed-Milad
16	Nov	11	12	13	14	15	16	17	11 <sup>th</sup> to 16 <sup>th</sup> Nov. Tutorials-III, 15 <sup>th</sup> Nov. Kanakadasa Jayanthi
17	Nov	18	19	20	21	22	23	24	21 <sup>st</sup> 22 <sup>nd</sup> & 23 <sup>rd</sup> Nov. Test-III
18	Nov/Dec	25	26	27	28	29	30	1	27 <sup>th</sup> Nov. Submission of IA Marks, 27 <sup>th</sup> Nov. Progress Report Dispatch, 27 <sup>th</sup> Nov. Dept Meeting, 30 <sup>th</sup> Nov. Final Attendance submission 29 <sup>th</sup> Nov. Last date for Proctor Book Entry, 30 <sup>th</sup> Nov. Last Working Day of 3 <sup>rd</sup> , 5 <sup>th</sup> & 7 <sup>th</sup> Sem B.E. classes, 30 <sup>th</sup> Nov. Submission of Attendance Register for attendances,
19	Dec	2	3	4	5	6	7	8	3 <sup>rd</sup> Dec. Commencement of Practical Exams for 3 <sup>rd</sup> , 5 <sup>th</sup> & 7 <sup>th</sup> BE,
20	Dec	9	10	11	12	13	14	15	Practical Exams for 3 <sup>rd</sup> , 5 <sup>th</sup> & 7 <sup>th</sup> BE,
21	Dec	16	17	18	19	20	21	22	16 <sup>th</sup> Dec. Commencement of Theory Exams for 3 <sup>rd</sup> , 5 <sup>th</sup> & 7 <sup>th</sup> BE,
22	Dec	23	24	25	26	27	28	29	25 <sup>th</sup> Dec. Christmas

**NOTE: Every Monday Proctor Counseling will be held in 4<sup>th</sup> hour class**

Prepared by:	Prof. Praveen N	Approved by:	Prof. Saptaraj (Retd.,)
Date & Sign:	17/11/19	Date & Sign:	17/11/19



|| JAI SRI GURUDEV ||

**S.J.C.INSTITUTE OF TECHNOLOGY, CHICKBALLAPUR**

**TIME TABLE FOR THE YEAR: 2019-20 (ODD SEMESTER)**

For the period: July 2019 TO November 2019

Version:2

Department: Aeronautical Engineering

Room No: LH 201 & LH 202

Staff Name: Dr. Bino Prince Raja D

Semester: III & V B.E.

DAYS/TIME	9.00am To 10.00am	10.00am To 10.50am	10.50am To 11.00am	11.00am To 11.50am	11.50am To 12.40pm	12.40pm To 1.30pm	1.30pm To 2.20pm	2.20pm To 3.10pm	3.10pm To 4.00pm	4.00pm To 4.10pm	4.10pm To 5.00pm
Monday	ICM (17AE52)	10.00am To 10.50am	Machine Shop - Batch 2 + Prof Vinay P	MOM (18AE34)	11.50am To 12.40pm	LUNCH BREAK	MOM (18AE34)	MOM (18AE34)	3.10pm To 4.00pm	4.00pm To 4.10pm	4.10pm To 5.00pm
Tuesday											
Wednesday											
Thursday	MOM (18AE34)		BREAK				Flight Simulation Lab - Batch 1 + Prof. Praveen .N		ICM (17AE52)		MOM (18AE34)
Friday							EC & FM Lab- Batch 2 + Prof. Vigneswaran CM				ICM (17AE52)
Saturday		MOM (18AE34)									

Prepared by:	Prof. Praveen .N	Approved by:	Gp. Capt. V. Rajan (Rettd.)
Date & Sign :	26/7/19	Date & Sign :	26/7/19

Department of Aeronautical Engineering  
S.J.C. Institute of Technology  
CHICKBALLAPUR-562191

**B. E. AERONAUTICAL ENGINEERING**  
**Choice Based Credit System (CBCS) and Outcome Based Education (OBE)**  
**SEMESTER - III**

**Mechanics of Materials**

Course Code	18AS33/18AE33	CIE Marks	40
Teaching Hours/Week (L:T:P)	(3:2:0)	SEE Marks	60
Credits	04	Exam Hours	03

**Course Learning Objectives:**

- Comprehend the basic concepts of strength of materials.
- Acquire the knowledge of stress, strain under different loadings.
- Understand the properties of materials.

**Module-1**

**Basics of linear elasticity:** The concept of stress & strain, state of stress & Strain at a point, Equilibrium equations, The state of plane stress and plane strain. Compatibility equations, Constitutive Laws (Hooke's Law), Stress-strain curves for brittle and ductile materials, Allowable stress, Material selection for structural performance.

**Simple & Compound Stresses:** Extension / Shortening of a bar, bars with cross sections varying in steps, bars with continuously varying cross sections. Elongation due to self-weight. Volumetric strain, expression for volumetric strain, elastic constants, simple shear stress, shear strain, temperature stresses, Introduction to Plane stress, stresses on inclined sections, principal stresses & strains, Analytical & graphical method (Mohr's Circle) to find principal stresses & strains.

**Module-2**

**Bending Moment and Shear Force in Beams:** Introduction, Types of beams, loads and reactions, shear forces and bending moments, rate of loading, sign conventions, relationship between shear force and bending moments. Shear force and bending moment diagrams for different beams subjected to concentrated loads, uniformly distributed load, (UDL) uniformly varying load (UVL) and couple for different types of beams.

**Euler-Bernoulli beam theory:** The Euler-Bernoulli assumptions, Implications of the Euler-Bernoulli assumptions, the Euler-Bernoulli Beam theory derivation, Bending stress equation, Moment carrying capacity of a section. Shearing stresses in beams, shear stress across rectangular, circular, symmetrical I and T sections (Only Numerical).

**Module-3**

**Deflection of Beams:** Introduction, Differential equation for deflection. Equations for deflection, slope and bending moment. Double integration method for cantilever and simply supported beams for point load, UDL, UVL and Couple. Macaulay's method.

**Torsion of Circular Shafts and Elastic Stability of Columns:** Introduction. Pure torsion, assumptions, derivation of torsional equations, polar modulus, torsional rigidity / stiffness of shafts. Power transmitted by solid and hollow circular shafts.

**Module-4**

**Virtual work principles:** Introduction, Equilibrium and work fundamentals, Principle of virtual work, Principle of virtual work applied to mechanical systems, Principle of virtual work applied to truss structures, Principle of virtual work applied to beams. Principle of complementary virtual work, internal virtual work in beams and solids.

**Energy methods:** Conservative forces, Principle of minimum total potential energy, Strain energy in springs, Strain energy in beams, Strain energy in solids, Applications to trusses, Development of a finite element formulation for trusses, Principle of minimum complementary, Energy theorems, Reciprocity theorems, Saint-Venant's principle.

**Module-5**

**Mechanical Properties of materials:**

**Fracture:** Type I, Type II and Type III.

**Creep:** Description of the phenomenon with examples. Three stages of creep, creep properties, stress relaxation.

**Fatigue:** Types of fatigue loading with examples, Mechanism of fatigue, fatigue properties, fatigue testing and S-N diagram.

**Course Outcomes:** At the end of the course the student will be able to:

- CO1: Apply the basic concepts of strength of materials.
- CO2: Compute stress, strain under different loadings.
- CO3: Distinguish the properties of different materials.

**Question paper pattern:**

- The question paper will have ten full questions carrying equal marks.
- Each full question will be for 20 marks.
- There will be two full questions (with a maximum of four sub-questions) from each module.
- Each full question will have sub-question covering all the topics under a module.
- The students will have to answer five full questions, selecting one full question from each module

Sl. No.	Title of the Book	Name of the Author/s	Name of the Publisher	Edition and Year
<b>Textbook/s</b>				
1	Strength of Materials	S. S. Bhavaikatii	Vikas Publications House, New Delhi	2012
2	Strength of Materials	S. Ramamrutham	Dhanapath Rai Publishing Company	2012
<b>Reference Books</b>				
1	Introduction to Aircraft Structural Analysis	T. H. G Megson	Butterworth-Heinemann	2007
2	Mechanics of Materials	Beer, F. P. and Johnston, R.	McGraw Hill Publishers	2006
3	Elements of Strength of Materials	Timoshenko and Young	East-West Press	1976
4	Structural Analysis	O. A. Bauchau and J. I. Craig	Springer Dordrecht Heidelberg London New York	

*(Handwritten signature)*  
 (v Rajan)  
 29/11/15

**PROFESSOR & HEAD**  
 Department of Aeronautical Engineering  
 S.J.C. Institute of Technology  
 CHICKBALLAPUR-562101

||Jai Sri Gurudev||  
**S.J.C. Institute of Technology, Chickballapur**  
**Department of Aeronautical Engineering**  
**List of III Sem B.E students 2019-20**

Sl. No.	USN	Name of the Student
1.	1SJ18AE001	ABDUL RAHMAN J
2.	1SJ18AE002	AFRIN TAJ P M
3.	1SJ18AE003	AKASH M
4.	1SJ18AE004	AKASH SIDDANGOUDA PATIL
5.	1SJ18AE005	AKSHAY KUMAR P S
6.	1SJ18AE006	ANNASAGARAM GOWTHAMI
7.	1SJ18AE007	ANUSHREE N
8.	1SJ18AE008	ARAVIND R NAIDU
9.	1SJ18AE009	ARJI BHARATH
10.	1SJ18AE010	BHASKAR S
11.	1SJ18AE011	BHAVANA A J
12.	1SJ18AE012	BINDUSHREE K
13.	1SJ18AE013	CHANDAN KUMAR A
14.	1SJ18AE014	CHAVALI BHIMA SANKARAM
15.	1SJ18AE015	CHIDANANDA
16.	1SJ18AE016	DHANUSH KUMAR B K
17.	1SJ18AE017	DURGAPRASAD N S
18.	1SJ18AE018	GIRIDHAR S
19.	1SJ18AE019	GIRISH N
20.	1SJ18AE020	GOWTHAM S
21.	1SJ18AE021	HARSHA D S
22.	1SJ18AE022	HARSHITH L
23.	1SJ18AE023	HARSHITHA K
24.	1SJ18AE024	HEMANTH B S
25.	1SJ18AE025	JANAPAREDDI SAIKUMAR
26.	1SJ18AE026	K KEERTHIVARDHAN
27.	1SJ18AE027	KOLLANA YESWANTH
28.	1SJ18AE028	MAHIMA T S
29.	1SJ18AE029	MANIKYA G
30.	1SJ18AE030	MANJESH KUMAR K P
31.	1SJ18AE031	MANOJ S
32.	1SJ18AE032	MANOJ SINGH H
33.	1SJ18AE033	MARIYAMBI T S
34.	1SJ18AE034	MEGHASHREE M S
35.	1SJ18AE035	MOHAMMED AZAM
36.	1SJ18AE036	MONIKA CHAVAN A

37.	ISJ18AE037	MYTHRI C
38.	ISJ18AE038	NAGAMANI J V
39.	ISJ18AE039	NAGESH D R
40.	ISJ18AE040	PRAJAKTA S LOKHANDE
41.	ISJ18AE041	PRAMODGOWDA T S
42.	ISJ18AE042	PRASAD BELGUNDKAR
43.	ISJ18AE043	RACHANA J
44.	ISJ18AE044	RAHUL P
45.	ISJ18AE045	RAKESH S
46.	ISJ18AE046	RAMYAKRISHNA K
47.	ISJ18AE047	RANJITH B S
48.	ISJ18AE048	RAVINDRA SREE CHENDAN SAI
49.	ISJ18AE049	SAI KEERTHAN B L
50.	ISJ18AE050	SAMPRUTHA A R
51.	ISJ18AE051	SOWBHAGYA M R
52.	ISJ18AE052	SRIDHAR K R
53.	ISJ18AE053	UJWAL N
54.	ISJ18AE054	UMESH RANA
55.	ISJ18AE055	USHA G
56.	ISJ18AE056	VAISHAK M
57.	ISJ18AE057	VARUN M
58.	ISJ18AE058	VEERESH
59.	ISJ18AE059	VIGNESH GOWDA P
60.	ISJ18AE060	YASHWANTH R
61.	ISJ18AE061	YASHWANTH S
62.	ISJ18AE062	YASHWANTH T H
63.	ISJ18AE063	YOGESH E S
64.	ISJ18AE064	NARINDER KUMAR

  
 [ROHITH. L-G]  
 Class Teacher

  
 PROFESSOR & HEAD 29/7/19  
 Department of Aeronautical Engineering  
 S.J.C. Institute of Technology  
 CHICKBALLAPUR-562101



Name of the staff: **Dr. Bino Prince Raja. D**  
 Subject: **Mechanics of Materials** Sub code: **18AE33**  
 Semester: **III**

Course Outcomes: At the end of the course students will be able to:

CO1	Apply the concepts of equations of linear elasticity corresponding to stress and strain (L3)
CO2	Illustrate the Shear force and Bending Moment diagrams (L3)
CO3	Study Euler-Bernoulli and Three dimensional beam theory with assumptions (L2)
CO4	Summarize the deflection of beams and concept of torsion (L2)
CO5	Illustrate principles of virtual work different energy methods (L3)
CO6	Examine the properties of fatigue, creep and fracture (L3)

	PO1	PO2	PO3	PO4	PO5	PO6	PO7	PO8	PO9	PO10	PO11	PO12	PSO1	PSO2
CO1	3	-	-	-	-	-	-	-	-	-	-	2	-	2
CO2	3	-	-	-	-	-	-	-	-	-	-	2	-	2
CO3	3	-	-	-	-	-	-	-	-	-	-	2	-	-
CO4	3	-	-	-	-	-	-	-	-	-	-	2	-	-
CO5	3	-	-	-	-	-	-	-	-	-	-	2	-	-
CO6	3	-	-	-	-	-	-	-	-	-	-	2	-	-

1: Slightly      2: Moderately      3: Substantially

8/12/19

*(V. Rajan)*  
 Department of Mechanical Engineering  
 S.J.C. Institute of Technology  
 CHICKBALLAPUR-562101

<b>CO-PO Justification</b>	
<b>CO</b>	
<b>CO1</b>	The knowledge of engineering fundamentals and analysis of complex problems are very much essential hence it is mapped to PO1& PO2. Lifelong learning is important for basic concepts of linear elasticity so it is mapped to PO12
<b>CO2</b>	The knowledge of basic and analysis of complex problems like SFD and BMD problems is required to determine the deflection and torsion, hence it is mapped to PO1, PO2 & PO12
<b>CO3</b>	Studying the Euler- Bernoulli and 3D beam theory is important, hence mapped to PO1. PO2 and PO12
<b>CO4</b>	The Knowledge of deflection of beam is important to analyze any structures, hence mapped to PO1, PO2 and PO12
<b>CO5</b>	Analyzing the virtual work principle to Truss structures and Beams are essential, hence it correlates with PO1&PO2. General understanding about Beams and strain calculation is necessary so it is mapped to lifelong learning PO12
<b>CO6</b>	Understanding the Mechanical properties of materials is very important hence it is strongly mapped to PO1, PO2& PO12
<b>CO</b>	
<b>CO-PSO Justification</b>	
<b>CO1</b>	The knowledge of engineering fundamentals and analysis of complex problems are very much essential hence it is mapped to PSO2
<b>CO2</b>	The knowledge of mathematic and analysis of complex problems is required to understand basic SFD and BMD concept, hence it is mapped to PSO1



**Module-4**

- 7 a. Explain the steps involved in unit load method applied to truss structures. (06 Marks)  
 b. Define the principle of virtual work for a particle. Obtain the equilibrium of a particle. (10 Marks)

OR

- 8 a. Explain Maxwell's theorem. (08 Marks)  
 b. Define a conservative force and obtain the work done by conservative force along any path joining two points. (08 Marks)

**Module-5**

- 9 a. Explain Tresca's criterion and Von Mises criterion. (08 Marks)  
 b. A steel tube of 25 mm external diameter and 18 mm internal diameter enclose a copper rod of 15 mm diameter. The ends are rigidly fastened to each other. Calculate the stress in the rod and the tube when the temperature is raised from 15°C to 200°C. Take  $\alpha_{st} = 11 \times 10^{-6}/^{\circ}\text{C}$ ,  $\alpha_{cu} = 18 \times 10^{-6}/^{\circ}\text{C}$ ,  $E_{st} = 200 \text{ GPa}$ ,  $E_{cu} = 100 \text{ GPa}$ . (08 Marks)

OR

- 10 a. Obtain the solution for simply supported circular plate of radius  $R_0$  under linear pressure distribution as shown in Fig.Q10(a).

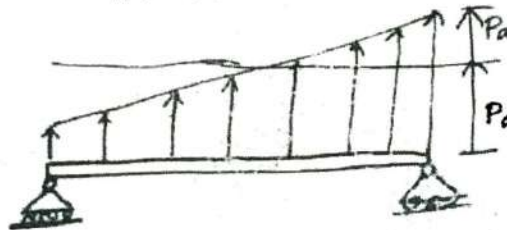

Fig.Q10(a)

- b. What is Kirchoff plate theory and mention its assumptions. (08 Marks)

\*\*\*\*\*

# CBCS Scheme

USN 15J15AE025

15AE34

## Third Semester B.E. Degree Examination, June/July 2017 Mechanics of Materials

Time: 3 hrs.

Max. Marks: 80

**Note: Answer any FIVE full questions, choosing one full question from each module.**

### Module-1

- 1 a. Derive the equilibrium equations in polar co-ordinates for a two dimensional state of stress. (10 Marks)
- b. The rectangular component at a point are given as follows :  
 $\sigma_x = 100\text{Mpa}$ ,  $\sigma_y = 75\text{Mpa}$ ,  $\sigma_z = 50\text{Mpa}$ ,  $\tau_{xy} = 70\text{Mpa}$ ,  $\tau_{yz} = 50\text{Mpa}$ ,  $\tau_{xz} = 30\text{Mpa}$ . Find the stresses on octahedral plane. (06 Marks)

OR

- 2 a. Draw the stress-strain curve for mild steel and mention the salient points. (04 Marks)
- b. Write a note on material selection for structural performance. (06 Marks)
- c. A stepped bar of steel, held between two supports as shown in Fig Q2(c), is subjected to loads  $P_1 = 80\text{kN}$  and  $P_2 = 60\text{kN}$ . Find the reactions developed at the ends A and B. (06 Marks)

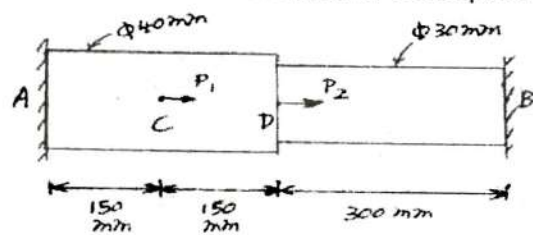

Fig Q2(c)

### Module-2

- 3 a. A beam of T section has a length of 2.5m and is subjected to a point load as shown in Fig Q3(a). Calculate the compressive bending stress and plot the stress distribution across the cross section of the beam. The maximum tensile stress is limited to 300MPa. Calculate the value of W. (12 Marks)

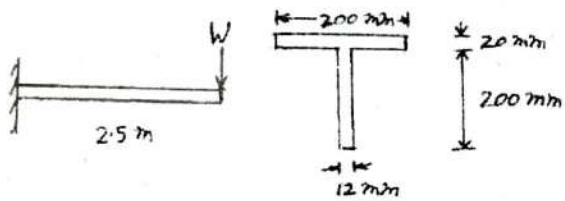

Fig Q3(a)

- b. Derive relations between intensity of load, shear force and bending moment. (04 Marks)

OR

- 4 a. What is three dimensional beam theory? Give its Kinematic description. (08 Marks)
- b. Find the principle centroidal bending stiffness of the beam shown in Fig Q4(b). The axial stiffness of section is  $S = Et$  (bth) (08 Marks)

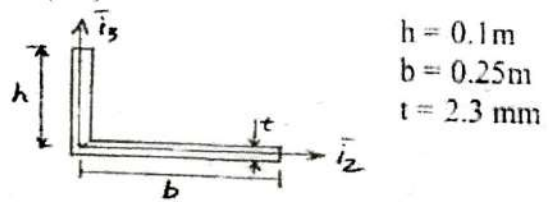

Fig Q4(b)

Important Note : 1. On completing your answers, compulsorily draw diagonal cross lines on the remaining blank pages.  
2. Any revealing of identification, appeal to evaluator and/or equations written eg. 42+8 = 50, will be treated as malpractice.

Module-3

- 5 a. A hollow circular shaft 200mm external diameter and thickness of metal 25mm is transmitting power at 200rpm. The angle of twist over a length of 2m was found to be  $0.5^\circ$ . Calculate the power transmitted and the maximum shear stress induced in the section. The modulus of rigidity of material is  $84 \text{ kN/mm}^2$ . (08 Marks)
- b. Discuss the application of Von mises criterion and Tresca's criterion for a propeller shaft under torsion and bending. (08 Marks)

OR

- 6 a. Derive equation for shear flow distribution in open section beams. (08 Marks)
- b. Calculate the position of the shear centre of the thin walled channel section shown in Fig Q6(b). The thickness 't' of the walls is constant. (08 Marks)

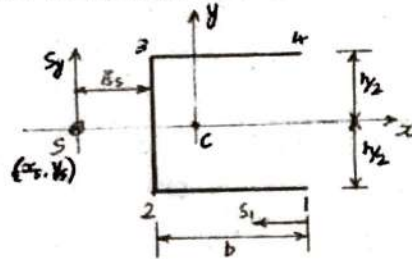

Fig Q6(b)

Module-4

- 7 a. Define principle of virtual work for a particle. Obtain the equilibrium of a particle. (08 Marks)
- b. What are the differences between principle of virtual work and principle of complementary virtual work? (08 Marks)

OR

- 8 a. Determine the strain energy of the prismatic beam AB for the loading as shown in Fig Q8(a). Take  $E = 200 \text{ GPa}$ . (10 Marks)

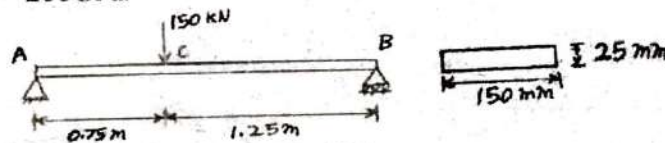

Fig Q8(a)

- b. Define :  
 i) Castiglione's theorem    ii) Clapeyron's theorem    iii) Maxwell's theorem. (06 Marks)

Module-5

- 9 a. A rigid rod ABCD is supported by a hinge at A and two wires at B and C as shown in Fig Q9(a). Determine the stresses and elongations of the two wires. Take  $E_s = 200 \text{ GPa}$  and  $E_c = 100 \text{ GPa}$ . (10 Marks)

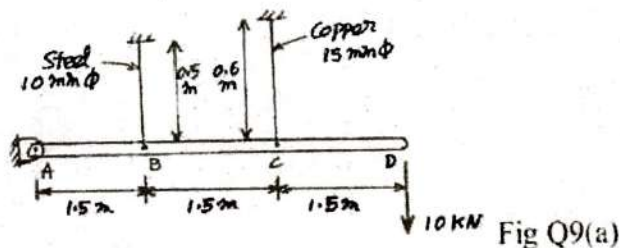

Fig Q9(a)

- b. Explain Tresca's and Von Mises criterions. (06 Marks)

OR

- 10 a. Deduce the principle of minimum total potential energy for Kirchhoff plates. (10 Marks)
- b. Explain Kirchhoff plate theory and mention its assumptions. (06 Marks)

**DEPARTMENT : AERONAUTICAL ENGINEERING**
**LESSON PLAN**

CLASS:5 <sup>th</sup> SEM SECTION: A	FACULTY: <b>Dr. BINO PRINCE RAJA.D</b>	SUBJECT: Mechanics of Materials	SUB CODE: 18AE33
---	---	------------------------------------	---------------------

**OBJECTIVE:** This course will enable students to

- 1) NComprehend the basic concepts of strength of materials.
- 2) Acquire the knowledge of stress, strain under different loadings.
- 3) Understand the properties of materials.

**PREREQUISITES:**
**EXPECTED OUTCOME:** After studying this course, students will be able to:

1. Apply the concepts of equations of linear elasticity corresponding to stress and strain (L3)
2. Illustrate the Shear force and Bending Moment diagrams (L3)
3. Study Euler-Bernoulli and Three dimensional beam theory with assumptions (L2)
4. Summarize the deflection of beams and concept of torsion (L2)
5. Illustrate principles of virtual work different energy methods (L3)
6. Examine the properties of fatigue, creep and fracture (L3)

**IT IS BASIC SUBJECT FOR:** Aircraft Structures and Materials

**SUBJECT APPLICATIONS:** Aircraft Structures and materials

Sl no.	TOPIC	PLANNED		ACTUAL		REMARKS
		No of Hours	Date	No of Hours	Date	
1.	<b>Module-1</b>					
2.	<b>Basics of linear elasticity:</b> The concept of stress & strain, state of stress & Strain at a point.	02	29/07,30/07	02	31/07 01/08	Completed
3.	Equilibrium equations, The state of plane stress and plane strain.	01	30/07	01	02/08	Completed
4.	Compatibility equations, Constitutive Laws (Hooke's Law),	01	01/08	01	06/08	Completed
5.	Stress-strain curves for brittle and ductile materials,	01	02/08	01	06/08	Completed
6.	Allowable stress, Material selection for structural performance.	01	05/08	01	06/08	Completed
7.	<b>Simple &amp; Compound Stresses:</b> Extension / Shortening of a bar	02	06/08,06/08	02	08/08 06/08	Completed
8.	Bars with cross sections varying in steps	01	08/08	01	19/08	Completed
9.	Bars with continuously varying cross sections. Elongation due to self-weight. Volumetric strain, expression for	01	09/08	02	19/08 19/08	Completed
10.	volumetric strain, elastic constants, simple shear stress, shear strain, temperature stresses, Introduction to Plane	01	13/08	01	20/08	Completed
11.	Stress, stresses on inclined sections, principal stresses & strains,	01	13/08	01	22/08	Completed



12.	Analytical & graphical method (Mohr's Circle) to find principal stresses & strains	01	16/08	01	22/08	Completed
	<b>MODULE-2</b>					
13.	<b>Bending Moment and Shear Force in Beams:</b> Introduction, Types of beams.	02	19/08,20/08	02	29/08 28/08	Completed
14.	Loads and reactions, shear forces and bending moments, rate of loading	01	20/08	01	29/08	Completed
15.	Sign conventions, relationship between shear force and bending moments.	01	22/08	01	29/08	Completed
16.	Shear force and bending moment diagrams for different beams subjected to concentrated loads	02	23,26/08	02	29/08 30/08	Completed
17.	Uniformly distributed load, (UDL) uniformly varying load (UVL) and couple for different types of beams.	02	27/08,27/08	02	03/09 03/09	Completed
18.	<b>Euler-Bernoulli beam theory:</b> The Euler-Bernoulli assumptions.	01	29/08	01	03/09	Completed
19.	Implications of the Euler-Bernoulli assumptions	01	30/08	01	03/09	Completed
20.	Euler-Bernoulli Beam theory derivation, Bending stress equation, Moment carrying capacity of a section.	02	03/09,03/09	02	05/09 06/09	Completed
21.	Shearing stresses in beams, shear stress across rectangular, circular, symmetrical I and T sections	02	05/09,09/09	02	07/09 17/09	Completed
22.	<b>Tutorial-I (06/09/19)</b>					
23.	<b>INTERNAL TEST-I (12/09-14/09)</b>					
24.	<b>Module-3</b>					
25.	<b>Deflection of Beams:</b> Introduction, Differential equation for deflection.	02	16/09,17/09	02	18/09 19/09	Completed
26.	Equations for deflection, slope and bending moment.	01	17/09	01	20/09	Completed
27.	Double integration method for cantilever and simply supported beams for point load.	02	19/09,20/09	02	23/09 26/09	Completed
28.	UDL, UVL and Couple. Macaulay's method.	02	23/09,24/09	01	27/09	Completed
29.	<b>Torsion of Circular Shafts and Elastic Stability of Columns:</b> Introduction. Pure torsion.	01	24/09	01	30/09	Completed
30.	Assumptions, derivation of torsional equations, polar modulus, torsional rigidity / stiffness of shafts.	01	26/09	01	01/10	Completed



31.	Power transmitted by solid and hollow circular shafts.	02	27/09,30/09	01	01/10	Completed
32.	<b>Module-4</b>					
33.	<b>Virtual work principles:</b> Introduction, Equilibrium and work fundamentals,	02	01/10,01/10	02	01/10 10/10	Completed
34.	Principle of virtual work, Principle of virtual work applied to mechanical systems	02	03,04/10	02	11/10 12/10	Completed
35.	Principle of virtual work applied to truss structures	02	10/10,14/10	01	12/10	Completed
36.	Principle of virtual work applied to beams. Principle of complementary virtual work	01	15/10	02	12/10 12/10	Completed
37.	Internal virtual work in beams and solids.	01	15/10	01	13/10	Completed
	<b>Tutorial-II (11/10/19)</b>					
	<b>INTERNAL TEST-II (17/10-19/10)</b>					
38.	<b>Energy methods:</b> Conservative forces, Principle of minimum total potential energy, Strain energy in springs,	02	21,22/10	02	13/10 15/10	Completed
39.	Strain energy in beams, Strain energy in solids, Applications to trusses,	02	22,24/10	02	15/10 21/10	Completed
40.	Development of a finite element	02	25,28/10	01	21/10	Completed
41.	Formulation for trusses, Principle of minimum complementary,	02	31/10,04/11	02	24, 30/10	Completed
42.	Energy theorems, Reciprocity theorems,	02	05,05/11	02	30,31/10	Completed
43.	Saint-Venant's principle.	02	07,08/11	05	01/10	Completed
44.	<b>Module-5</b>					
45.	<b>Mechanical Properties of materials:</b>	02	11/11,12/11	02	04/11 05/11	Completed
46.	<b>Fracture:</b> Type I, Type II and Type III.	02	12,18/11	02	05,07/11	Completed
47.	<b>Creep:</b> Description of the phenomenon with examples. Three stages of creep, creep properties, stress	02	19,19/11	02	06, 11/11	Completed
48.	<b>Fatigue:</b> Types of fatigue loading with examples,	02	25,26/11	02	18,14/11	Completed
49.	Mechanism of fatigue, fatigue properties, fatigue testing	02	26,28/11	02	18,19/11	Completed
50.	S-N diagram	01	29/11	02	19,21/11	Completed
51.	<b>Tutorial-III (14/11/19)</b>					
52.	<b>Internals-III (21/11-23/11)</b>					



Assignments and Mini Project

Assignment - I Submit By:	Enter Equilibrium, Compatibility eqn Numericals on bars Varying Sections
Assignment - II Submit By:	Numericals on SFD & BMD & Torsion
Assignment - III Submit By:	Numericals on Deflection of beam,
Mini Project Submit By:	

Literature to be Referred for the Course:

Book Type	Code	Title & Author	Publication Information		
			Edition	Publisher	Year
Text Books	T1	Strength of Materials, S. S. Bhavaikatii	3 <sup>rd</sup> Edition	Vikas Publication House, New Delhi	2012
	T2	Strength of Materials, S. Ramamrutham	-	Dhanapath Rai Publishing Company	2012
Reference Books	R1	Introduction to Aircraft Structural Analysis, T. H. G Megson	-	Butterworth-Heinemann	2007
	R2	Mechanics of Materials, Beer, F. P. and Johnston. R	-	McGraw Hill Publishers	2006
	R3	Elements of Strength of Materials, Timoshenko and Young	-	East-West Press	1976
	R4	Structural Analysis, O. A. Bauchau and J. I. Craig	-	Springer Dordrecht Heidelberg London New York	-

Comments by Faculty: Completed all the modules within the stipulated period

Comments by HOD:

Prepared by	Dr. Binu Prince RAJA . D	Reviewed by		Approved by	
Date&sign	 29/7/19	Date&sign	 29/7/19	Date&sign	 29/7/19

PROFESSOR & HEAD  
 Department of Aeronautical Engineering  
 S.J.C. Institute of Technology  
 CHICKBALLAPUR-562101

Department: **Aeronautical Engineering**Faculty name: **Dr. Bino Prince Raja.D**Semester: **III**Subjects: **Mechanics of Materials – 18AE33**

Sl no.	Risk description	Subjects	Action plan	Date of completion	Remarks
<b>Course delivery</b>					
1.1	Critical subject	MOM	<ul style="list-style-type: none"> <li>- Conducting Remedial class on Wednesday from 4PM to 5PM to the students who scored less than 14 marks in Test-1.</li> <li>- Planning to conduct a preparatory exam for the whole class after last working day</li> </ul>	30/11/2019	Executing
1.4	Change in teaching Methodology	MOM	<ul style="list-style-type: none"> <li>- Solving previous Question Paper Questions, Giving Question Banks, ICT, and hand written notes</li> <li>- Asking the students to present a seminar on a given topic</li> </ul>	30/11/2019	Executing
<b>Students</b>					
2.1.	Student counselling	MOM	<ul style="list-style-type: none"> <li>- Counselling the students about the difficulties they are facing with the core aeronautical subjects</li> <li>- Giving suggestions about how to prepare for internals and for external exams</li> </ul>	30/11/2019	Executing
2.2	Proctor effectiveness	MOM	<ul style="list-style-type: none"> <li>-Counselling session on every Monday</li> <li>- Time to time updating of the information to the HOD and the same to their parents.</li> </ul>	30/11/2019	Executing
<b>Result analysis</b>					
3.1	Low results	MOM	- Expecting Good Results	30/11/2019	Executing
<b>General issues</b>					
4.2	Missing classes	MOM	- Intimating to their parents through class teacher and proctor.	30/11/2019	Executing
4.3	Student Grievance addressing	MOM	- Addressing and action will be taken on respective complaints by the HOD and also intimated to parents.	30/11/2019	Executing

Bino  
05/10/19

(V. Rajan) 2/8/19.

S J C INSTITUTE OF TECHNOLOGY, CHICKBALLAPUR  
Department of Aeronautical Engineering

# Assignment Rubrics

Subject Name: Mechanics of Materials

Subject Code: 18AE33

Semester & Section: III

Period: 29/7/2019 to 30/11/2019

Faculty Name: Dr. Bino Prince Raja.D

Assignment Marks: 10 Marks

Symbolic Representation of Rubrics	Marks Indication	Total
A	Answer up to the question / Description ( 1 – 2) Marks	2
B	Examples / Figures / (1 – 2) Marks	2
C	Problem Solution Steps / Calculations (1-2) Marks	2
D	Quiz	4
	Final Marks	10

*Bino*  
05/08/19  
Staff Signature

*(V Rajan)*  
HOD  
5/8/19

PROFESSOR & HEAD  
Department of Aeronautical Engineering  
S.J.C. Institute of Technology  
CHICKBALLAPUR-562101

**//JAI SRI GURUDEV//**  
**S.J.C INSTITUTE OF TECHNOLOGY**  
**DEPARTMENT OF AERONAUTICAL ENGINEERING**  
**Mechanics of Materials (18AE33)**  
**Tutorials-I**

Sl. No.	Questions	CO	Levels
<b>MODULE-I</b>			
1.	A Steel plate of thickness 10mm tapers uniformly from 60mm at one end to 40mm at another end in a length of 600mm if bar is subjected to a load of 60kN find it's extension take $E=2 \times 10^5$ pascal what is the percentage error if average area used for calculating the extension.	CO1	L3
2.	The extension of a bar is uniformly tapering of diameter $d+a$ to $d-a$ in the length is calculated by treating as a bar of uniform cross section of average dimension $d$ what is the percentage error.	CO1	L3
3.	1.5m long steel bar is having a uniform diameter of 40mm for a length of 1m and in the next 0.5m it's diameter gradually reduces from 40mm to 20mm determine the elongiation of this bar when subjected to axial load of 160kN given that young's modulus is $200\text{GN/m}^2$ .	CO1	L3
4.	If a tension bar is found to tapers from $d+a$ diameter to $d-a$ diameter prove that the error involved in using the mean diameter to calculate tha young's modulus is $[10a/D]^2$ percent.	CO1	L3
5.	Determine the change in length width and thickness of the steel bar which is 4m long, 30mm wide and 20mm thick is subjected to an axial pull of 30kN in the direction of length take $E=2 \times 10^5 \text{ N/mm}^2$ , $M=0.3$ (poissons ratio) also determine the volumetric stain, change in volume, final volume.	CO1	L3
6.	A short of piece of steel pipe is to carry an axial compressive load of 1000kN with a factor of safty of 2 against yielding, if the thickness of the pipe is $1/5^{\text{th}}$ of outside diameter, find the minimum required outside diameter $d$ . yield stress of steel is 280MPa.	CO1	L3
7.	The following data refers to a mild steel specimen tested in a laboratory. Diameter of specimen = 25mm ,gauge length of	CO1	L3

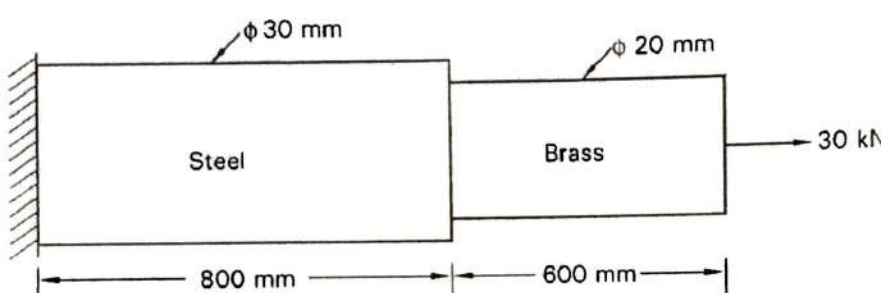
	<p>specimen=200mm, Extension under a load of 20kN=0.04mm          load at yield point=150Kn, Maximum load=225kN      Length          of specimen after failure=275mm</p> <p>Neck diameter=18.25mm. Determine:</p> <ul style="list-style-type: none"> <li>➤ Young's modulus</li> <li>➤ yield stress</li> <li>➤ Ultimate stress</li> <li>➤ Percentage elongation</li> <li>➤ Percentage reduction in area</li> </ul> <p>Safe stress adopting a factor of safety of 2.5</p>		
8.	<p>The composite bar shown in the below figure is subjected to a tensile force of 30kN. the extension observed is 0.74mm. find the young's modulus of brass, if young's modulus of steel is <math>2 \times 10^5 \text{N/mm}^2</math></p> 	CO1	L3
9.	<p>A steel flat of thickness 16mm tapers uniformly from 80mm at one end to 50mm at other end in a length of 800mm if the flat is subjected to a load of 120kN, find the extension of the flat. <math>E=2 \times 10^5 \text{MPa}</math>. also calculate the percentage error if average area is used for calculating it's extension.</p>	CO1	L3
10.	<p>A mild steel bar 50mm square in section and 150mm long is subjected to axial thrust of 200kN. half the lateral strain is prevented by the application of uniform external pressure of suitable intensity if <math>E=200 \text{GPa}</math> and poisson's ratio =0.3, calculate the alteration in the length of the bar.</p>	CO1	L3
11.	<p>Calculate the modulus of rigidity and bulk modulus of a cylindrical bar of diameter 25mm and length 1.6m, if the longitudinal strain in a bar during tensile test is 4 times the lateral strain. also find the change in volume, when the bar is subjected to a hydrostatic pressure of <math>100 \text{N/mm}^2</math>. <math>E=1 \times 10^5 \text{N/mm}^2</math>.</p>	CO1	L3
12.	<p>A short cast iron pillar of <math>625 \text{mm}^2</math> cross section carries an axial compressive load of 100kN. calculate 1)Normal and shear</p>	CO1	L3

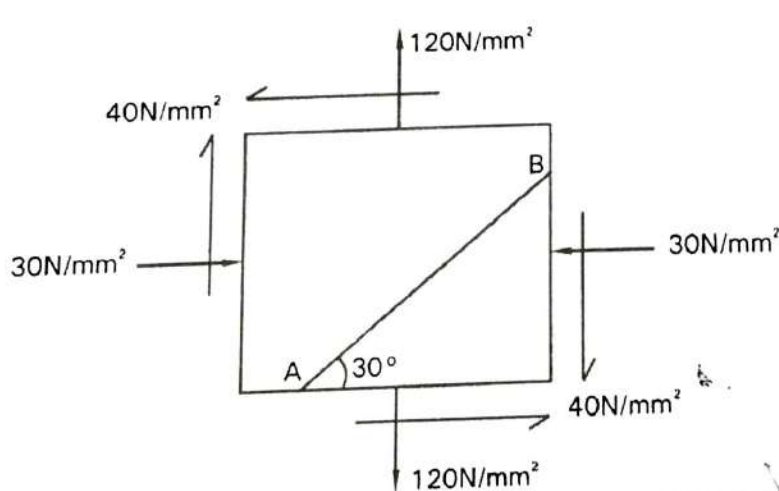
	stress on a plane inclined at $30^\circ$ to the axis of the pillar. 2) Shear and normal stress on plane on which the shear stress is maximum.		
13.	A point in a strained material is subjected to a tensile stress of $120\text{N/mm}^2$ and a compressive stress of $80\text{N/mm}^2$ acting at right angles to each other. find the normal stress, tangential stress, resultant stress and its obliquity (direction) on a plane inclined at angle of $30^\circ$ with a axis of compressive stress. also find the maximum shear stress.	CO1	L3
14.	A point in a strained material, the stress on two planes at right angles to each other are $80\text{N/mm}^2$ (tensile) and $40\text{N/mm}^2$ (tensile) each of the above stresses is accompanied by a shear stress of $60\text{N/mm}^2$ . determine (1) Normal stress, shear stress and resultant stress on an oblique plane inclined at an angle of $45^\circ$ to the axis of minor tensile stress. also find major principal stress, minor principal stress and their location, maximum shear stress and its location	CO1	L3
15.	At certain point in a strained material the stress condition shown in the below figure exists find, <ol style="list-style-type: none"> <li>1. Normal and shear stresses on the inclined plane AB</li> <li>2. Principal stresses and principal planes</li> <li>3. Maximum shear stresses and their planes.</li> </ol> 	CO1	L3
16.	At a certain point in strained material the values of normal stress across two planes at right angle to each other are $80\text{MPa}$ and $32\text{MPa}$ , both tensile and there is a shear stress of $32\text{MPa}$ cw on the plane carrying $80\text{MPa}$ stresses across the planes as shown in the fig. below determine (1) Maximum and minimum normal stresses and locate their planes. (2) Maximum shear stress and specify its plane	CO1	L3

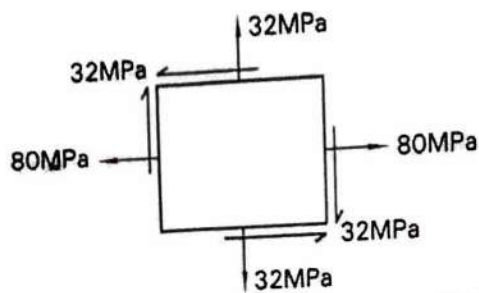

17. An element is subjected to stresses as shown in the fig. as determine (1) Principal stresses and their directions. (2) Normal and tangential stress on plane AC.

CO1

L3

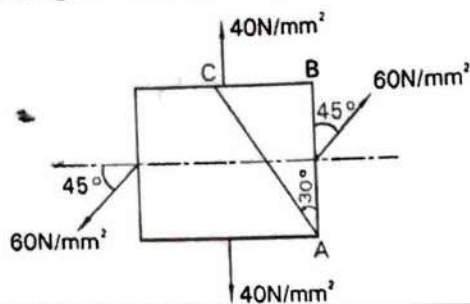

18. Show that the sum of the normal stresses on any two plane at right angles in a general two dimensional stress system is constant.

CO1

L3

19. A point in a strained material is subjected pure shear stress as shown in fig. below determine the maximum and minimum stresses inclined and orientation of their planes by mohr's circle method

CO1

L3

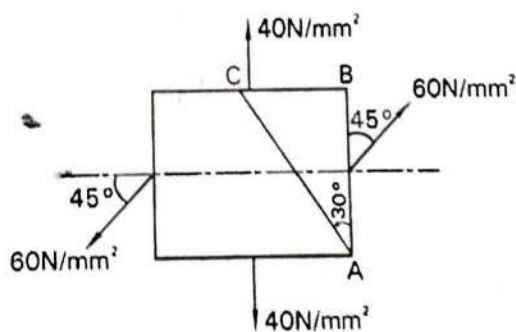

20. The state of stress in two dimensionally stressed body is shown in the fig. below determine the principal stresses, principal plane, maximum shear stress and their planes.

CO1

L3

21. A stepped bar is subjected to an external load as shown in fig .  
 a) calculate the change in length of the bar . $E=200\text{GPa}$  for aluminium and  $E=100\text{GPa}$  for copper.

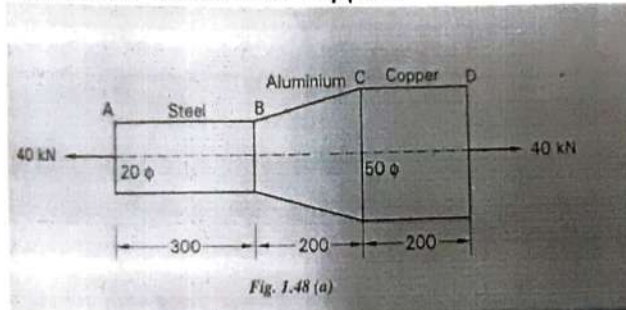

CO1 L3

22. A member ABCD is subjected to a point load as shown in the fig. Calculate a) Force P necessary for equilibrium A  
 b) Total elongation of the Bar .take  $E=210\text{GN/mm}^2$

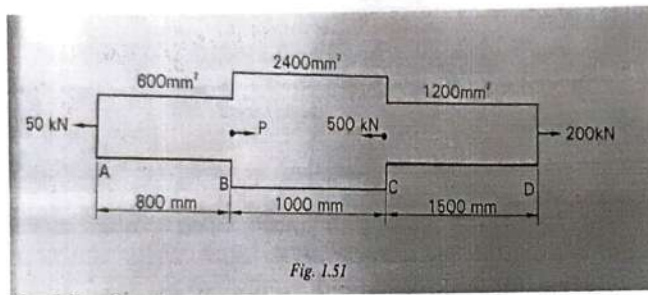

CO1 L3

23. A brass having a cross sectional area of  $1000\text{mm}^2$  is subjected to an axial force as shown in the fig. Determine the total elongation of the bar if  $E=105\text{GPa}$  .

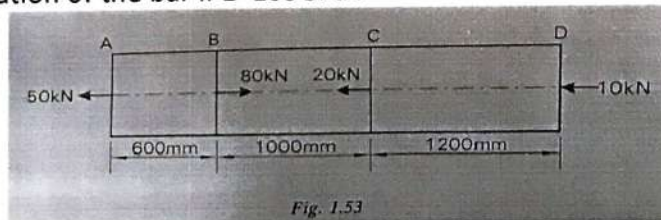

CO1 L3

24. A steel bar of 25mm external diameter and 18mm internal diameter encloses a copper rod of 15mm diameter .the ends are rigidly fastened to each other .calculate the stress in the rod and the tube when the temperature is risen from  $15^{\circ}$  to  $200^{\circ}\text{C}$  .take  $\alpha_{st}=11 \times 10^{-6}/^{\circ}\text{C}$ ,

CO1 L3

25.  $\alpha_{cu}=18 \times 10^{-6}/^{\circ}\text{C}$ ,  $E_{st}=200\text{GPa}$ ,  $E_{cu}=100\text{GPa}$ .

CO1 L3

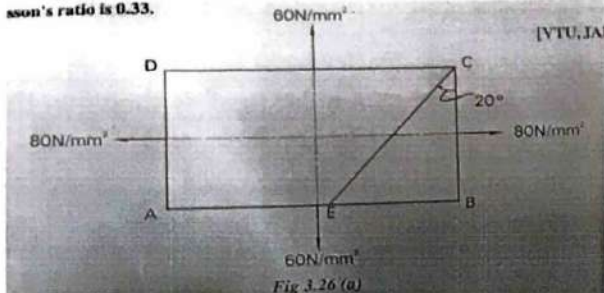
26.	A point is strained in a material is subjected to a tensile stress of $500\text{N/mm}^2$ and $300\text{N/mm}^2$ in two mutually perpendicular planes. Calculate normal ,tangential ,resultant stress and its obliquity on a plane making an angle of $30^\circ$ with the axis of the second stress . also find maximum shear stress.	CO1	L3
27.	An element is subjected to a principal tensile stress across two perpendicular planes as shown in the fig. a) Determine Normal stress ,shear and the resultant stress on the plane EC . determine also its obliquity. What will be the intensity of the stress which is acting along will produce the same maximum strain if the poisson's ratio is 0.33. 	CO1	L3
28.	Derive the equation for Bars with continuously varying Cross sections with i) Rectangular Cross section ii) Circular Cross section	CO1	L3
29.	Derive elongation due to self-weight and with uniformly tapering section due to self-weight.	CO1	L3
30.	Define volumetric strain. Express the volumetric strain due to three mutually perpendicular stresses.	CO1	L3
31.	Define all the 4 Elastic Constants.	CO1	L3
32.	Derive the relationship between Modulus of elasticity (E) & Bulk	CO1	L3
33.	Derive the relationship between Modulus of elasticity (E) & Rigidity Modulus (G).	CO1	L3
34.	Derive the Stresses on an inclined Plane corresponding to i) Uniaxial stresses ii) Biaxial Stresses	CO1	L3
35.	Draw the Stress-Strain diagram for ductile and brittle materials. Mention the salient points.	CO1	L3
36.	Derive Equilibrium equation of 3D stress system.	CO1	L3
37.	Write a note on Plane Stress and Plane Strain.	CO1	L3

38	Write a note on Material selection for Structural Performance.	CO1	L3
39	Derive Compatibility Equation.	CO1	L3
40	Define Load factor and Allowable stress.	CO1	L3

Bim  
05/09/19

~~hoooo~~  
(V Rajan)  
05/09/19.



Internal Test Question paper

Name of the staff/s: Dr. BINO PRINCE RAJA.D

Date: 03/09/2019 Signature: *Bino*  
*03/09/19*

Reviewer's Signature: *[Signature]*  
*3/9/19*

S.J.C. Institute of Technology  
Department of Aeronautical Engineering  
Test: I Semester: III  
Subject Name & Code: Mechanics of Materials - 18AE33

Duration: 90 Minutes

Max Marks: 30

NOTE: 1. Answer all three main questions,  
2. Missing data if any, can be suitably assumed

Question Number		Marks	CO	Levels
1	a) Derive Equilibrium equation of 3D stress system.	06	CO1	L-3
	b) Draw the Stress-Strain diagram for ductile materials. Explain the salient points.	04	CO1	L-3
<b>OR</b>				
2	a) Derive Compatibility Equation.	06	CO1	L-3
	b) Explain about Plane Stress and Plane Strain.	04	CO1	L-3
3	Derive the equation for Bars with continuously varying Cross sections with i) Rectangular Cross section ii) Circular Cross section	10	CO1	L-3
<b>OR</b>				



4	a) Derive the Stresses on an inclined Plane corresponding to  i) Uniaxial stresses ii) Biaxial Stresses	10	CO1	L-3
5	a) A Steel plate of thickness 10mm tapers uniformly from 60mm at one end to 40mm at another end in a length of 600mm if bar is subjected to a load of 60kN find it's extension take $E=2 \times 10^5$ pascal what is the percentage error if average area used for calculating the extension.	05	CO1	L-3
	b) A point in a strained material is subjected to a tensile stress of $120\text{N/mm}^2$ and a compressive stress of $80\text{N/mm}^2$ acting at right angles to each other. find the normal stress, tangential stress, resultant stress and it's obliquity(direction) on a plane inclined at angle of $30^\circ$ with a axis of compressive stress. also find the maximum shear stress.	05	CO1	L-3

OR



a) At certain point in a strained material the stress condition shown in the below figure exists find,

- i) Normal and shear stresses on the inclined plane AB
- ii) Principal stresses and principal planes
- iii) Maximum shear stresses and their planes.

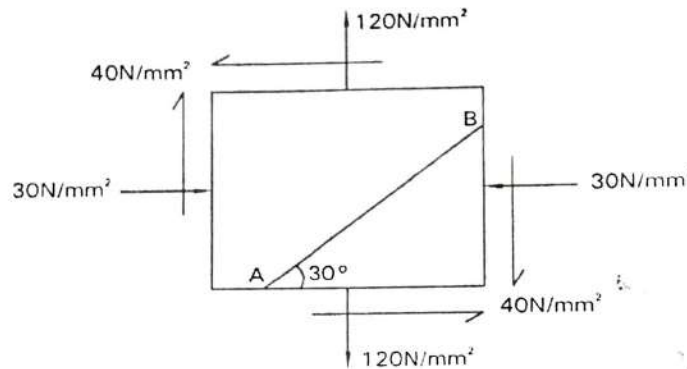

05

C01

L-3

6

b) A stepped bar is subjected to an external load as shown in fig . a) calculate the change in length of the bar . $E=200\text{GPa}$  for aluminium and  $E=100\text{GPa}$  for copper.

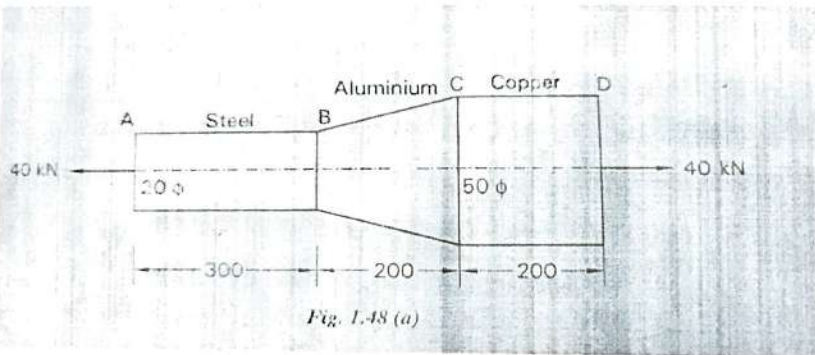

05

C01

L-3

**COURSE OUTCOMES:**

**On successful completion of this course, students should be able to**

<b>C01</b>	Apply the concepts of equations of linear elasticity corresponding to stress and strain (L3)
<b>C02</b>	Draw the Shear force and Bending Moment diagrams (L3)
<b>C03</b>	Study Euler-Bernoulli and Three dimensional beam theory (L3)
<b>C04</b>	Summarize the deflection of beams and concept of torsion (L3)
<b>C05</b>	Illustrate principles of virtual work different energy methods (L3)
<b>C06</b>	Study the basics of fatigue, creep and fracture (L3)



DEPARTMENT: AERONAUTICAL ENGINEERING

Scheme & Solutions- TEST- I/II/III

Date: 03/09/19

Semester: III

Subject Title: Mechanics of Materials

Subject Code: 18AE33

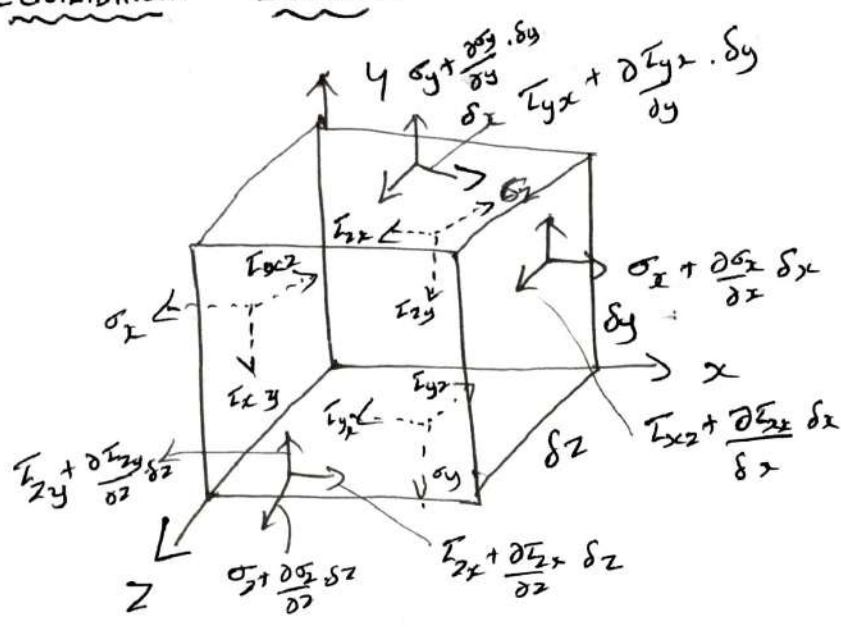
Question Number	Solution	Marks Allocated
1 a.)	<p><u>EQUILIBRIUM EQUATION</u></p>  <p>Considering the Normal and Shear Stress acting          on x-direction (Free equilibrium)</p> $\frac{\partial \sigma_x}{\partial x} + \frac{\partial \tau_{yx}}{\partial y} + \frac{\partial \tau_{zx}}{\partial z} + X = 0$ <p>Y-direction</p> $\frac{\partial \sigma_y}{\partial y} + \frac{\partial \tau_{zy}}{\partial z} + \frac{\partial \tau_{xy}}{\partial x} + Y = 0$ <p>Z-direction</p> $\frac{\partial \sigma_z}{\partial z} + \frac{\partial \tau_{xz}}{\partial x} + \frac{\partial \tau_{yz}}{\partial y} + Z = 0$ <p><u>Moment equilibrium</u></p> $\left. \begin{aligned} \tau_{xy} &= \tau_{yx} \\ \tau_{xz} &= \tau_{zx} \\ \tau_{yz} &= \tau_{zy} \end{aligned} \right\}$	<p>02</p> <p>01</p> <p>01</p> <p>01</p> <p>01</p>





Subject Title: MOM

Subject Code: 18AE33

Question Number	Solution	Marks Allocated
	$\frac{\partial^2 \nu_{xy}}{\partial x \partial y} = \frac{\partial^2 \epsilon_y}{\partial x^2} + \frac{\partial^2 \epsilon_x}{\partial y^2}$ $\frac{\partial^2 \nu_{yz}}{\partial y \partial z} = \frac{\partial^2 \epsilon_y}{\partial z^2} + \frac{\partial^2 \epsilon_z}{\partial y^2}$ $\frac{\partial^2 \nu_{xz}}{\partial x \partial z} = \frac{\partial^2 \epsilon_z}{\partial x^2} + \frac{\partial^2 \epsilon_x}{\partial z^2}$	02
	$2 \frac{\partial^2 \epsilon_x}{\partial y \partial z} = \frac{\partial}{\partial y} \left[ \frac{\partial \nu_{yz}}{\partial z} - \frac{\partial \nu_{xz}}{\partial y} + \frac{\partial \nu_{xy}}{\partial z} \right]$ $2 \frac{\partial^2 \epsilon_y}{\partial x \partial z} = \frac{\partial}{\partial x} \left[ \frac{\partial \nu_{yz}}{\partial z} - \frac{\partial \nu_{xz}}{\partial y} + \frac{\partial \nu_{xy}}{\partial z} \right]$ $2 \frac{\partial^2 \epsilon_z}{\partial x \partial y} = \frac{\partial}{\partial z} \left[ \frac{\partial \nu_{yz}}{\partial z} + \frac{\partial \nu_{xz}}{\partial y} - \frac{\partial \nu_{xy}}{\partial z} \right]$	02
b.)	<p><u>Plane Stress</u></p> <p>In mathematical term, a state of Plane Stress in one in which stress along Z-direction is zero.</p> <p><u>Plane Strain</u></p> <p>Plane Strain is a 2D state of strain in which all the shape changes of a material happen on a single plane. The strain state is called plane strain.</p>	02



Subject Title: MOM

Subject Code: 18AE33

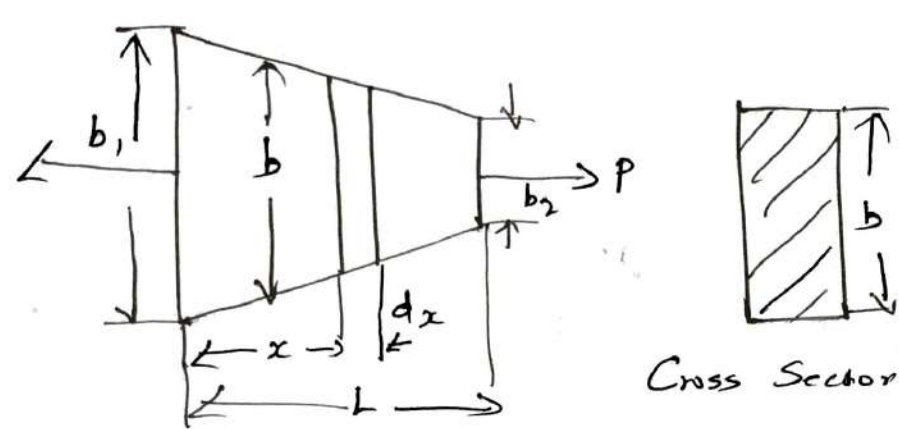
Question Number	Solution	Marks Allocated
3.1	<p><u>Bars with Continuously Varying Cross Sections</u></p> <p>1.) <u>Rectangular Cross Section</u></p>  <p>Rate of change of breadth is <math>\frac{b_1 - b_2}{L}</math></p> $A = t(b_1 - kx)$ <p>Extension = <math>\frac{P dx}{(b_1 - kx) EE}</math></p> <p>∴ Total extension of bar is</p> $= \frac{P}{EE} \int_0^L \frac{dx}{b_1 - kx}$ $= \frac{PL}{EE(b_1 b_2)} \log \frac{b_1}{b_2}$	<p>02</p> <p>01</p> <p>01</p> <p>01</p>



Subject Title: MOM

Subject Code: 18AE33

Question Number	Solution	Marks Allocated
	<p>(ii) <u>Circular</u> <u>Cross</u> <u>Section</u></p> <p>The diagram is same as above. Instead of <math>b</math>, '<math>d</math>' will be replaced.</p>  $k = \frac{d_1 - d_2}{L}$ $A = \frac{\pi}{4} (d_1 - kx)^2$ <p>Extension of element = <math>\frac{P dx}{\frac{\pi}{4} (d_1 - kx)^2 E}</math></p> <p>Extension of the bar = <math>\int_0^L \frac{P dx}{\frac{\pi}{4} (d_1 - kx)^2 E}</math></p> $= \frac{4P}{\pi E (d_1 - d_2)} \left[ \frac{1}{d_2} - \frac{1}{d_1} \right]$ $\Delta = \frac{4PL}{\pi E d_1 d_2}$ <p><math>\therefore</math> Uniform bar = <math>\frac{PL}{\frac{\pi d^2 E}{4}}</math></p> <p>tapering bar = <math>\frac{4PL}{\pi E d_1 d_2}</math></p>	<p>01</p> <p>02</p> <p>01</p> <p>01</p>



Subject Title: MOM

Subject Code: 18AE33

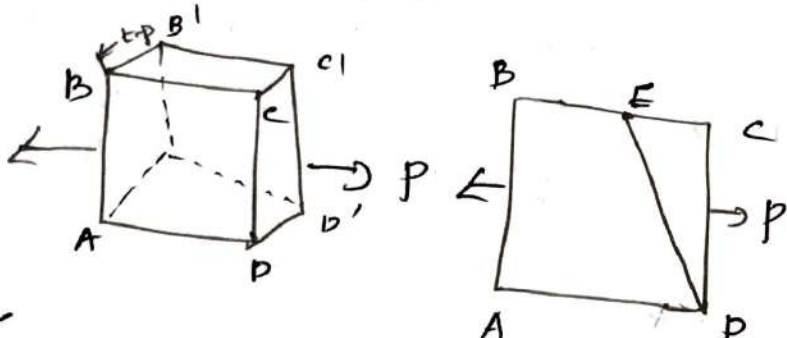
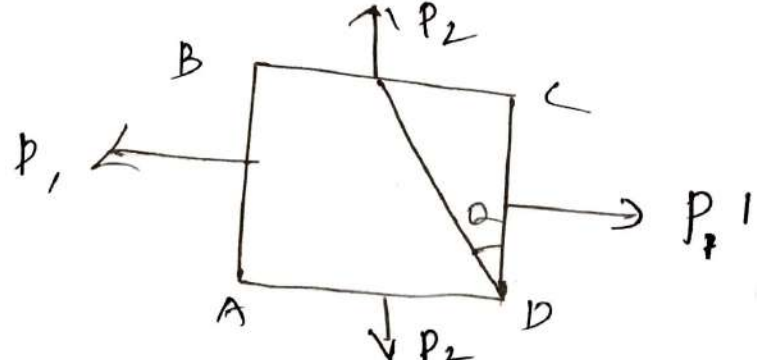
Question Number	Solution	Marks Allocated
4.)	<p><u>Stresses on an inclined plane</u></p> <p>i.) <u>Uniaxial Stresses</u></p>  <p><math>\Sigma</math> Forces normal to DE = 0,</p> $P_n = P \cos 2\theta \quad \dots (1)$ <p><math>\Sigma</math> Forces parallel to DE = 0</p> $P_t = \frac{P}{2} \sin 2\theta \quad \dots (2)$ <p>From eqn (1) <math>P_n</math> is max, when <math>\theta = 0</math></p> <p>From eqn (2) <math>P_t</math> is max, <math>2\theta = 90^\circ</math>, <math>\theta = 45^\circ</math></p> <p>(ii) <u>Biaxial Stresses</u></p> 	<p>02</p> <p>01</p> <p>01</p> <p>01</p> <p>01</p>



Subject Title: MOM

Subject Code: 18AE33

Question Number	Solution	Marks Allocated
	<p><math>\sum</math> Forces normal to plane, DEFO</p> $P_n = P_1 \cos 2\theta + P_2 \sin 2\theta \dots$ <p><math>\sum</math> Force Parallel to Plane, DEFO</p> $P_t = \frac{P_1 - P_2}{2} \sin 2\theta \dots$ <p>Resultant Stress, <math>R = \sqrt{P_n^2 + P_t^2} \dots</math></p> $\tan \phi = \frac{P_n}{P_t} \dots$	<p>01</p> <p>01</p> <p>01</p> <p>01</p>
<p>5 a.)</p>	<p><u>Given data</u></p> <p><math>t = 10 \text{ mm}, b_1 = 60 \text{ mm}, b_2 = 40 \text{ mm}</math>  <math>L = 600 \text{ mm}, P = 60 \text{ kN}</math>  <math>E = 2 \times 10^5 \text{ N/mm}^2</math></p> <p>Extension of the tapering bar of Rectangular Section = <math>\Delta = \frac{PL}{E(b_1 b_2)} \log \frac{b_1}{b_2}</math></p> $= 0.3649 \text{ mm}$ <p><math>\therefore</math> Average Cross Section is considered, <math>\Delta = \frac{PL}{A_{av} E}</math></p>	<p>01</p> <p>02</p>



Subject Title: MOM

Subject Code: 18AE33

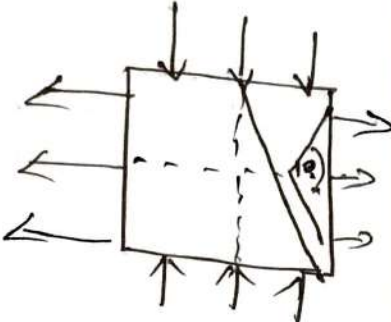
Question Number	Solution	Marks Allocated
	$A_{av} = 0.360 \text{ m} \times 560 \text{ mm}^2$ $\Delta = 0.360 \text{ mm}$ <p><math>\therefore</math> Percentage error = 1.3428</p>	01
b.)	<p><u>Given data</u></p> $\sigma_1 = 120 \text{ N/mm}^2$ $\sigma_2 = 80 \text{ N/mm}^2$ $\theta = 30^\circ$  <p>1.) Normal Stress</p> $\sigma = 70 \text{ N/mm}^2 \text{ (Compressive)}$ <p>(i) Tangential Stress</p> $\tau = -86.6 \text{ N/mm}^2$ <p>(ii) Result Stress <math>\sigma_R = 113.35 \text{ N/mm}^2</math></p> <p>(iv) Angle of obliquity <math>\phi = \tan^{-1} \left( \frac{\sigma_T}{\sigma_N} \right)</math></p> $= 51.05^\circ$ <p>(v) Max. Shear Stress <math>\sigma_{max} = \pm \left( \frac{\sigma_1 - \sigma_2}{2} \right)</math></p> $= \pm 100 \text{ N/mm}^2, \text{ when } \theta = 45^\circ$	01 01 01 01 01



Subject Title: MOM

Subject Code: 18AE33

Question Number	Solution	Marks Allocated
6a.)	<p><u>Given data</u></p> $\sigma_x = -30 \text{ N/mm}^2$ $\sigma_y = 120 \text{ N/mm}^2$ $\tau_{xy} = -40 \text{ N/mm}^2, \theta = 90-30^\circ = 60^\circ$ <p>(i) Normal Stress</p> $\sigma_n = \frac{\sigma_x + \sigma_y}{2} + \left( \frac{\sigma_x - \sigma_y}{2} \right) \cos 2\theta + \tau_{xy} \sin 2\theta$ $= 117.14 \text{ N/mm}^2$ <p>(ii) Shear Stress</p> $\tau = -\left( \frac{\sigma_x - \sigma_y}{2} \right) \sin 2\theta + \tau_{xy} \cos 2\theta$ $= -44.952 \text{ N/mm}^2$ <p>(iii) Principal Stresses and Planes</p> $\sigma_1 = 130 \text{ N/mm}^2$ $\sigma_2 = -40 \text{ N/mm}^2$ $\theta_1 = 14.036^\circ, \theta_2 = 104.036^\circ$ <p>(iv) <math>\tau_{\max} = \pm 85 \text{ N/mm}^2</math></p> $\sigma_c = 85 \text{ N/mm}^2$ $\theta_1 = 30.964^\circ$ $\theta_2 = 59.036^\circ$	<p>01</p> <p>01</p> <p>01</p> <p>01</p>



Subject Title: MOM

Subject Code: 18AE33

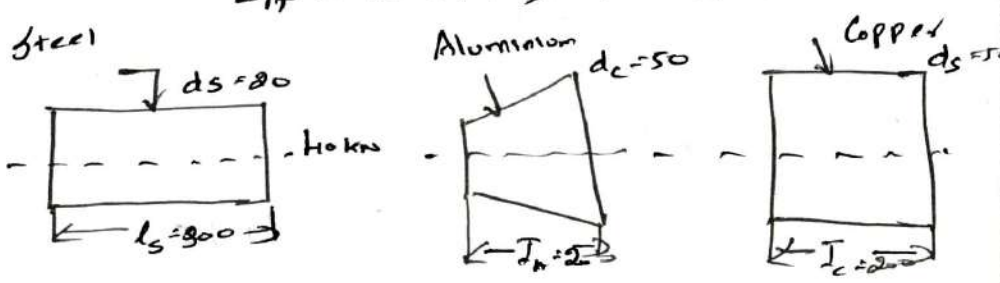
Question Number	Solution	Marks Allocated
6b.)	<p><u>Given data</u></p> <p><math>E_s = 200 \text{ GPa}</math> , <math>E_c = 100 \text{ GPa}</math>  <math>E_A = 70 \text{ GPa}</math> , <math>P = 40 \text{ kN}</math></p>  <p><math>\therefore</math> Total elongation :</p> $\delta l = \delta l_s + \delta l_A + \delta l_c$ $= \frac{P_s l_s}{A_s E_s} + \frac{P_A l_A}{A_A d_c d_s} + \frac{P_c l_c}{A_c E_c}$ <p><math>\therefore P_s = P_A = P_c = P</math></p> $\delta l = 0.3772 \text{ mm}$	<p>01</p> <p>01</p> <p>01</p> <p>01</p> <p>01</p>
<p><i>[Signature]</i> 8/9/19</p> <p>Reviewer</p>	<p><i>[Signature]</i> (V Rajin) 8/9/19</p> <p>HOD</p>	<p><i>[Signature]</i> 03/09/19</p> <p>Staff incharge</p>

|| Jai Sri Gurudev ||  
**S.J.C. Institute of Technology, Chickballapur**  
**Department of Aeronautical Engineering**  
**Rubrics-I**

**Subject: Mechanics of Materials**

**Subject code: 18AE33**

Sl. No.	USN	NAME OF THE STUDENT	A	B	C	D	Total
1	1SJ18AE001	ABDUL RAHMAN J	3	1	3	1	08
2	1SJ18AE002	AFRIN TAJ P M	A	A	A	A	A
3	1SJ18AE003	AKASH M	4	1	3	1	9
4	1SJ18AE004	AKASH SIDDANGOUDA PATIL	4	1	3	1	9
5	1SJ18AE005	AKSHAY KUMAR P S	A	A	A	A	A
6	1SJ18AE006	ANNASAGARAM GOWTHAMI	3	2	3	2	10
7	1SJ18AE007	ANUSHREE N	4	2	3	1	10
8	1SJ18AE008	ARAVIND R NAIDU	3	1	3	2	9
9	1SJ18AE009	ARJI BHARATH	3	1	3	1	8
10	1SJ18AE010	BHASKAR S	A	A	A	A	A
11	1SJ18AE011	BHAVANA A J	4	1	4	1	10
12	1SJ18AE012	BINDUSHREE K	4	1	4	1	10
13	1SJ18AE013	CHANDAN KUMAR A	A	A	A	A	A
14	1SJ18AE014	CHAVALI BHIMA SANKARAM	4	1	3	1	9
15	1SJ18AE015	CHIDANANDA	4	1	3	2	10
16	1SJ18AE016	DHANUSH KUMAR B K	4	1	3	2	10
17	1SJ18AE017	DURGAPRASAD N S	3	1	3	3	10
18	1SJ18AE018	GIRIDHAR S	3	1	3	1	8
19	1SJ18AE019	GIRISH N	3	1	4	2	10
20	1SJ18AE020	GOWTHAM S	A	A	A	A	A
21	1SJ18AE021	HARSHA D S	3	1	3	1	8
22	1SJ18AE022	HARSHITH L	3	2	3	2	10
23	1SJ18AE023	HARSHITHA K	4	1	4	1	10
24	1SJ18AE024	HEMANTH B S	4	1	4	1	10
25	1SJ18AE025	JANAPAREDDI SAIKUMAR	3	1	3	1	8

26	1SJ18AE026	K KEERTHIVARDHAN	3	1	3	1	8
27	1SJ18AE027	KOLLANA YESWANTH	4	1	4	1	10
28	1SJ18AE028	MAHIMA T S	3	1	3	1	8
29	1SJ18AE029	MANIKYA G	4	1	4	1	10
30	1SJ18AE031	MANOJ S	4	1	4	1	10
31	1SJ18AE032	MANOJ SINGH H	4	1	4	1	10
32	1SJ18AE033	MARIYAMBI T S	4	1	4	1	10
33	1SJ18AE034	MEGHASHREE M S	3	1	3	2	9
34	1SJ18AE035	MOHAMMED AZAM	2	1	3	1	7
35	1SJ18AE036	MONIKA CHAVAN A	4	1	4	1	10
36	1SJ18AE037	MYTHRI C	4	1	3	1	9
37	1SJ18AE038	NAGAMANI J V	4	1	3	1	9
38	1SJ18AE039	NAGESH D R	3	1	4	2	10
39	1SJ18AE040	PRAJAKTA S LOKHANDE	3	1	4	2	10
40	1SJ18AE041	PRAMODGOWDA T S	4	1	4	1	10
41	1SJ18AE042	PRASAD BELGUNDKAR	3	1	4	1	9
42	1SJ18AE043	RACHANA J	3	1	4	2	10
43	1SJ18AE044	RAHUL P	3	1	3	1	8
44	1SJ18AE045	RAKESH S	4	1	3	2	10
45	1SJ18AE046	RAMYAKRISHNA K	4	1	3	1	9
46	1SJ18AE047	RANJITH B S	A	A	A	A	A
47	1SJ18AE048	RAVINDRA SREE CHENDAN SAI	4	1	3	2	10
48	1SJ18AE049	SAI KEERTHAN B L	2	1	2	1	6
49	1SJ18AE050	SAMPRUTHA A R	4	1	3	2	10
50	1SJ18AE051	SOWBHAGYA M R	4	1	3	2	10
51	1SJ18AE052	SRIDHAR K R	3	1	3	1	8
52	1SJ18AE053	UJWAL N	2	1	3	1	7
53	1SJ18AE054	UMESH RANA	4	1	3	1	9
54	1SJ18AE055	USHA G	4	1	3	2	10
55	1SJ18AE056	VAISHAK M	4	1	3	1	9
56	1SJ18AE057	VARUN M	2	1	3	1	7
57	1SJ18AE058	VEERESH	4	1	3	2	10
58	1SJ18AE059	VIGNESH GOWDA P	1	1	2	1	5
59	1SJ18AE060	YASHWANTH R	3	1	3	1	8

60	1SJ18AE061	YASHWANTH S	4	1	3	2	10
61	1SJ18AE062	YASHWANTH T H	4	1	3	1	9
62	1SJ18AE063	YOGESH E S	A	A	A	A	A
63	1SJ18AE064	NARINDER KUMAR	3	1	3	1	8
64	1SJ18AE0	MOHAN REDDY	1	1	3	1	6

A = Description for the answer B = Figures or Diagrams C = Numericals and derivations  
D = Timely submission

*Buz*  
*25/10/19*







//JAI SRI GURUDEV//  
**S.J.C INSTITUTE OF TECHNOLOGY**  
**DEPARTMENT OF AERONAUTICAL ENGINEERING**  
**Mechanics of Materials (18AE33)**

**Tutorials-II**

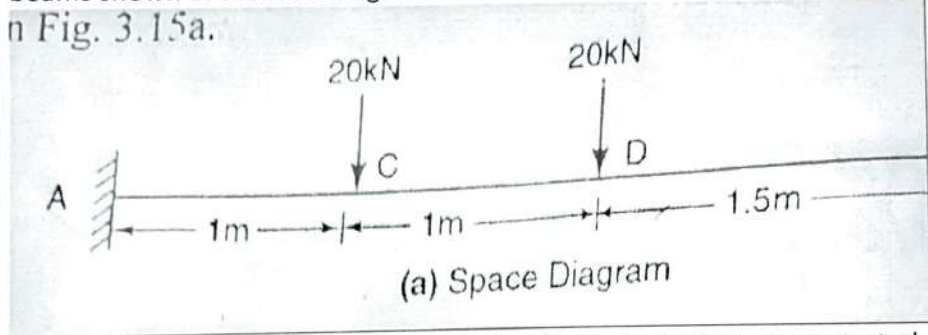
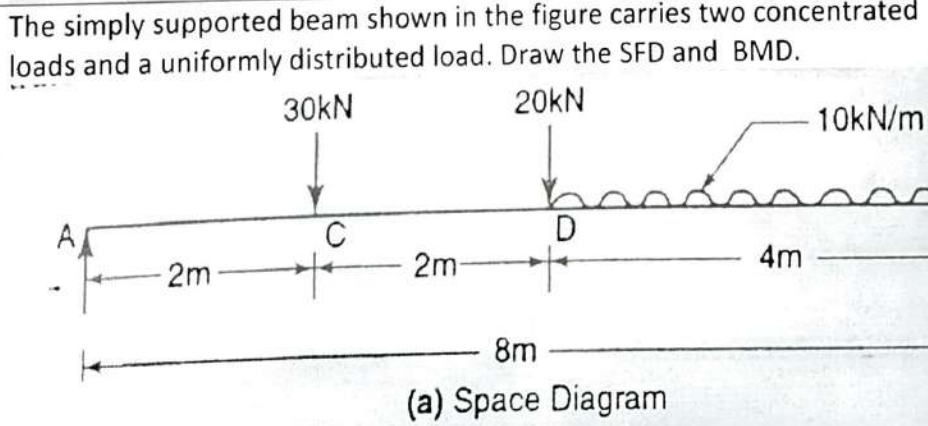
Sl. No.	Questions	CO	Levels
<b>MODULE-II</b>			
1.	Derive the equation for <b>Cantilever beam</b> with Point load, UDL and UVL load.	CO2	L3
2.	Derive the equation for <b>Simply supported beam</b> with Point load, UDL and UVL load.	CO2	L3
3.	Derive the equation for <b>Overhanging beam</b> with Point load.	CO2	L3
4.	Explain about the following i)Types of beams ii)Types of supports and iii) Types of Loads	CO2	L2
5.	Explain about the Euler-Bernoulli Assumptions.	CO2	L2
6.	Explain about the Euler-Bernoulli Implication.	CO2	L2
7.	Derive the Beam theory derivation with assumptions.	CO2	L3
8.	Draw the bending moment and shear force diagram for the cantilever beams shown in the below figure. n Fig. 3.15a.	CO2	L3
			
9.	The simply supported beam shown in the figure carries two concentrated loads and a uniformly distributed load. Draw the SFD and BMD.	CO2	L3
			
10.	A simply supported beam AB of 6M span is loaded as shown in the figure .Draw the SFD and BMD.	CO2	L3

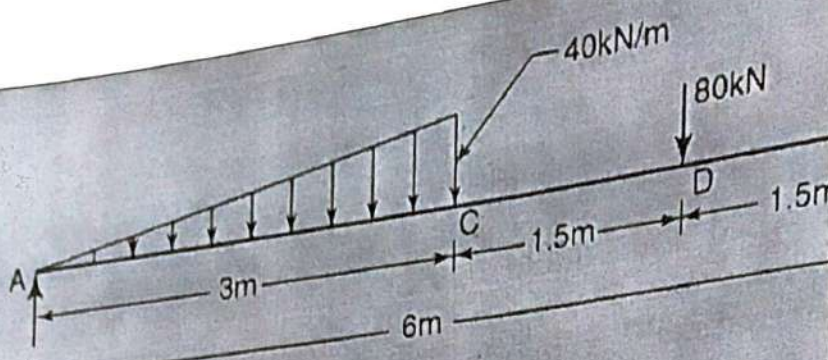
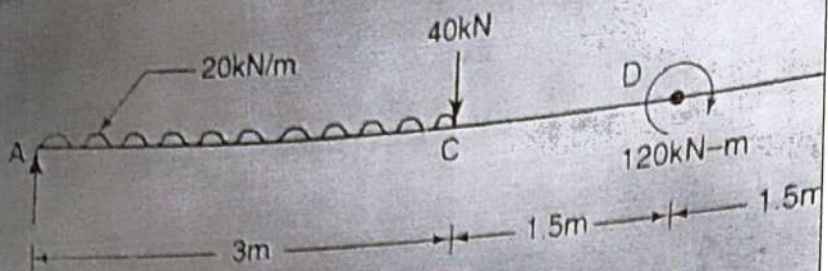
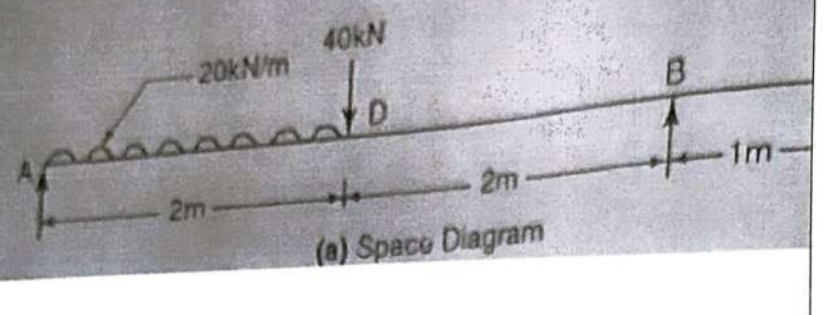
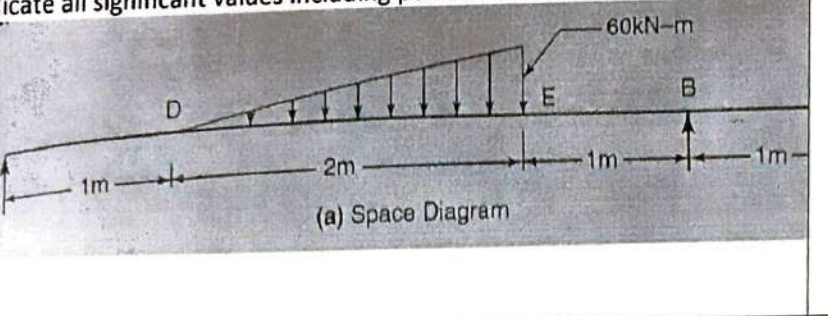
	 <p>(a) Space Diagram</p>	CO2	L3
11.	<p>Draw the SFD and BMD for the beam shown in the figure.</p>  <p>(a) Space Diagram</p>	CO2	L3
12.	<p>Draw the BMD and SFD for the overhanging beam shown in the figure. Clearly indicate the point of contraflexure.</p>  <p>(a) Space Diagram</p>	CO2	L3
13.	<p>Draw the BMD and SFD for the overhanging beam shown in the figure. Indicate all significant values including point of contraflexure.</p>  <p>(a) Space Diagram</p>	CO2	L3
14.	<p>For the beam shown in the figure determine the magnitude of the load P acting at C such that the reaction at the supports A and B are equal.</p>	CO2	L3



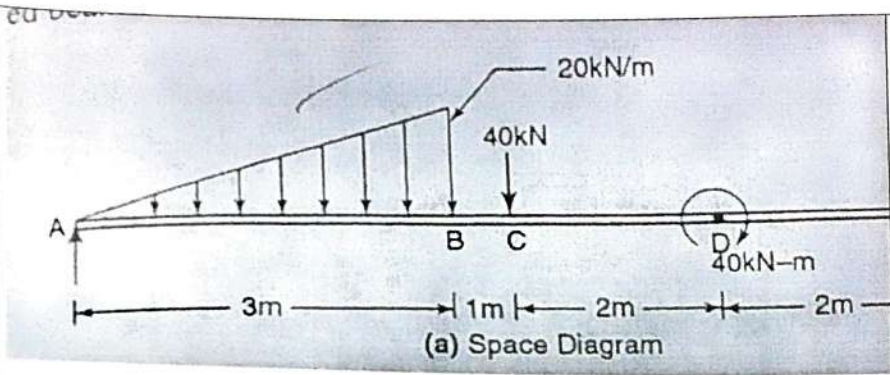

18. Draw the SFD and BMD for the beam shown in the figure and mark the salient points. Find the points of contraflexure and maximum bending moment.

CO2 L3

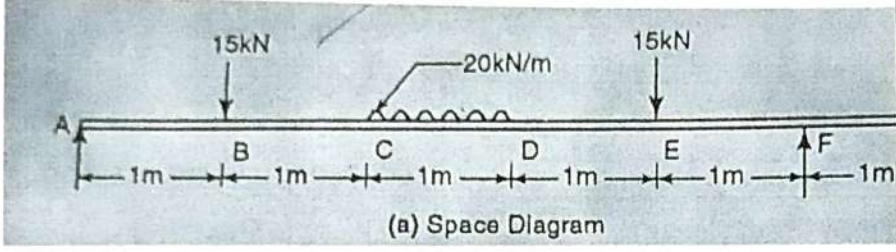

19. For the given stress compare the moment of resistance of a beam of square section when placed 1) with its two sides horizontal . 2) with its diagonal horizontal.

CO2 L3

20. The T section shown in the figure below is used for a simply supported beam over a span of 4m. It carries a uniformly distributed load of 8kN/m over its entire span. Calculate the maximum tensile and compressive stresses occurring in the section .

CO2 L3

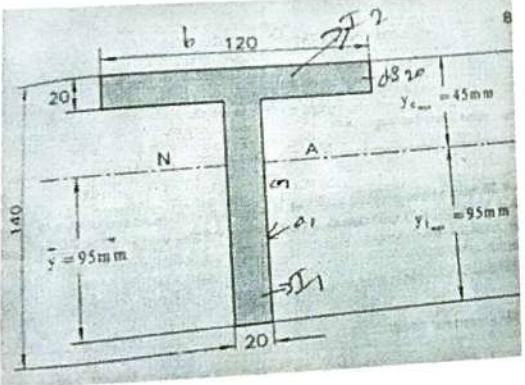

21. A cast iron test beam 25mm\*25mm cross-section area and 1m long, supported at its ends fail when a central load of 800 N is applied on it .

CO2 L3

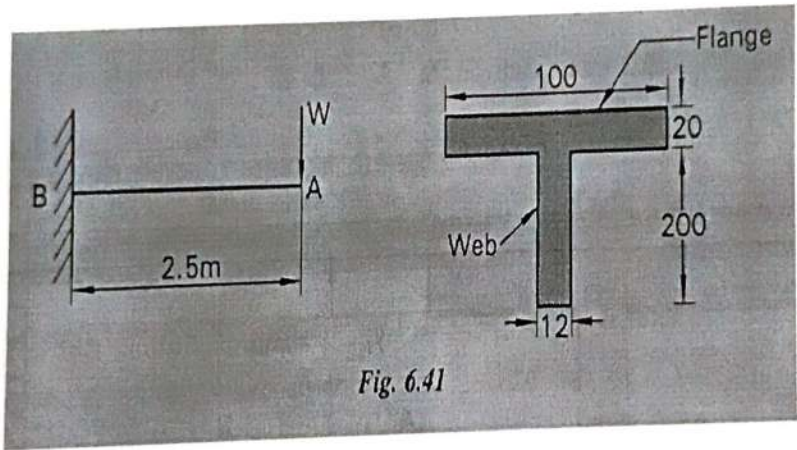
	what UDL will break a cantilever of same material 50mm wide, 100mm deep and 2m long .		
22.	A simply supported beam of 200mm wide and 300mm deep supports an uniformly distributed load of intensity $w$ kN/m over a span of 4m. calculate the safe intensity of load that the beam can carry, if the permissible stress in bending and shear are $56 \text{ N/mm}^2$ and $4 \text{ N/mm}^2$ respectively .	CO2	L3
23.	A cantilever has a length of 3m. its cross-section is of T-section with flanges $100\text{mm} \times 20\text{mm}$ and web $200\text{mm} \times 12\text{mm}$ , the flange is in tension. What is the intensity of the UDL that can be applied if the maximum tensile stress is limited to $30\text{N/mm}^2$ . Also compute the maximum compressive stress.	CO2	L3
24.	A beam of T section has a length of 2.5m and is subjected to a point load as shown in the below figure . calculate the compressive bending stress and plot the stress distribution across the cross-section of the beam . the maximum tensile stress is limited to $300\text{MPa}$ . calculate the value of $W$ .	CO2	L3
	 <p style="text-align: center;">Fig. 6.41</p>		
25.	A rectangular beam of 200mm wide and 300mm deep is subjected to a shear force of 60kN. Determine (i) Average shear stress (ii) maximum shear stress (iii) shear stress at a distance of 50mm above the neutral axis. Sketch the variation of the shear stress along the deep of the beam .	CO2	L3
26.	A beam of I section has flange $100\text{mm} \times 20\text{mm}$ and web $200\text{mm} \times 12\text{mm}$ is subjected to a vertical shear force of 200kN . Find the shear stress at the flange , junction and neutral axis . also sketch the stress distribution diagram.	CO2	L3
27.	A beam of an I section consists of $180\text{mm} \times 15\text{mm}$ flange and a web of $280\text{mm} \times 15\text{mm}$ thickness . it is subjected to a bending moment of $120\text{kNm}$ and a shear force of 60kN . sketch the bending and shear stress distribution along the depth of the section .	CO2	L3

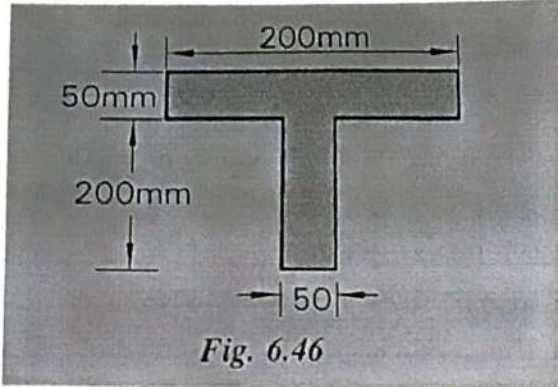
28.	<p>A T shaped cross-section of a beam as shown in the below figure is subjected to a vertical shear force of 100 kN . calculate the shear stress at the neutral axis junction and flange . MI about the horizontal neutral axis is <math>0.0001134m^4</math>.</p>  <p style="text-align: center;"><i>Fig. 6.46</i></p>	CO2	L3
<b>MODULE-III</b>			
29.	Derive the Torsional Equation.	CO3	L3
30.	Explain about the Torsional rigidity and Torsional Strength	CO3	L3
31.	Explain about the Power Transmitted by the shaft for solid circular shafts and Hollow shafts.	CO3	L3
32.	What length is required for a solid steel shaft of 12 mm in diameter so that the cross-section at one end can be rotated at $90^\circ$ with respect to other end with out exceeding an allowable shear stress of 70MPa in the shaft ? Assume G as 80MPa.	CO3	L3
33.	Determine the diameter of the solid shaft which will transmit 440 kW at 280rpm if the maximum torsional shear stress is to be limited to 40 N/mm <sup>2</sup>	CO3	L3
34.	A solid circular shaft has to transmit power of 1000kW at 120rpm .find the diameter of the shaft, if the shear stress of the material must not exceed 80N/mm <sup>2</sup> . the maximum torque 1.25 times of its mean . what percentage of saving in material would be obtained if the shaft is replaced by a hollow one whose internal diameter is 0.6 times the external diameter, the length , material and maximum shear stress is being same .	CO3	L3
35	A solid shaft is subjected to a maximum torque of 25kNm. Find a suitable diameter of solid shaft, if the allowable shear stress and the twist are limited to 80 N/mm <sup>2</sup> and $1^\circ$ respectively to a length of 20 times the diameter of the shaft.	CO3	L3
36	A hollow circular steel shaft has to transmit 60kW at 210rpm such that the maximum shear stress does not exceed 60MN/m <sup>2</sup> .If the ratio of internal to external diameter is equal to $\frac{3}{4}$ and the value of rigidity modulus is 84GPa. Find the dimension of the shaft and the angle of twist in a length	CO3	L3

	of 3m.		
38	A solid shaft rotating at 1000rpm transmits 50kW . maximum torque is 20% more then the mean torque. Material of the shaft has the allowable stress of 50MPa and modulus of rigidity is 80GPa. Angle of twist in the shaft should not exceed $1^\circ$ in one meter length. Determine the diameter of the shaft .	CO3	L3
39	A hollow shaft having its internal diameter 40% of its external diameter, transmits 562.5kW power t 100 rpm . determine the internal and external diameter of the shaft if the shear stress is not to exceed $60 \text{ N/mm}^2$ and the twist in a length of 2.5 m should not exceed 1.3 degree. The maximum torque being 25% greater then mean. Modulus of rigidity is $9/10^4 \text{ N/mm}^2$	CO3	L3
40	Determine the ratio of power transmitted by a hollow shaft and a solid shaft when both have same weight ,length ,material and speed. The diameter of the solid shaft is 150mm and the external diameter of the hollow shaft is 250mm	CO3	L3

*Ray*  
15/10/19

*Proof*  
(V Rajan)  
15/10/19

## Internal Test Question paper

Name of the staff/s: Dr. BINO PRINCE RAJA.D

Date: 11/10/2019

Signature: *Bino*  
*11/10/19*Reviewer's Signature: *[Signature]*  
*15/10/19*

S.J.C. Institute of Technology  
Department of Aeronautical Engineering

Test: II Semester: III

Subject Name & Code: Mechanics of Materials - 18AE33

Date: 18/10/2019

Time: 9.30-11am

Max Marks: 50

NOTE: 1. Answer all the questions. Missing datas can be suitably assumed.

Question Number		Marks	CO	Levels
1	Derive the equation for Cantilever beam with Point load and UDL	10	CO2	L-3
OR				
2	Derive the equation for Simply supported beam with Point load and UDL	10	CO2	L-3
3	Derive the Beam theory derivation with assumptions.	10	CO2	L-3
OR				
4	Explain about the Euler-Bernoulli Assumptions and Implication.	10	CO2	L-3
5	Draw the Shear Force and Bending moment diagram for the cantilever beam shown below. <div style="text-align: center;"> </div>	10	CO2	L-3
OR				
6	A simply supported beam AB of 6M span is loaded as shown in the figure .Draw the SFD and BMD.	10	CO2	L-3

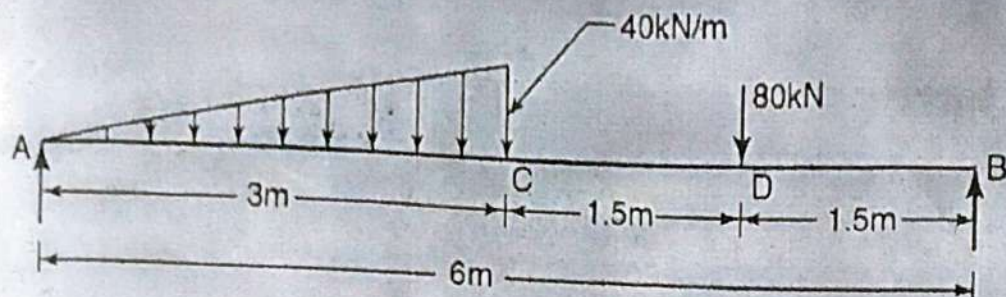

(a) Space Diagram

The T section shown in the figure below is used for a simply supported beam over a span of 4m. It carries a uniformly distributed load of 8kN/m over its entire span. Calculate the maximum tensile and compressive stresses occurring in the section .

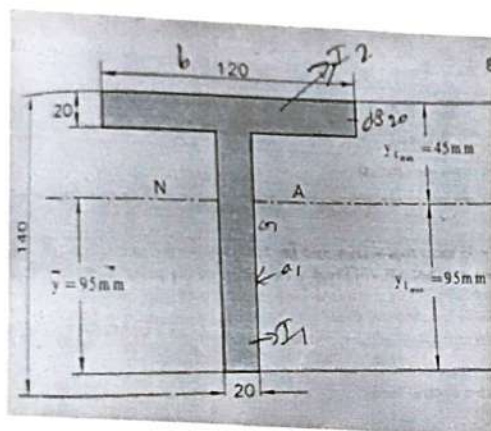

7

10

C02

L-3

OR

8

A beam of I section has flange 100mm\*20mm and web 200mm\*12mm is subjected to a vertical shear force of 200kN . Find the shear stress at the flange , junction and neutral axis . also sketch the stress distribution diagram.

10

C02

L-3

9

Derive the Torsional Equation for Solid circular shaft.

10

C03

L-3

OR

10

A solid circular shaft has to transmit power of 1000kW at 120rpm .find the diameter of the shaft, if the shear stress of the material must not exceed 80N/mm<sup>2</sup> . the maximum torque 1.25 times of its mean . what percentage of saving in material would be obtained if the shaft is replaced by a hollow one whose internal diameter is 0.6 times the external diameter, the length , material and maximum shear stress is being same .

10

C03

L-3

**COURSE OUTCOMES:****On successful completion of this course, students should be able to**

CO1	Apply the concepts of equations of linear elasticity corresponding to stress and strain (L3)
CO2	Draw the Shear force and Bending Moment diagrams, and Study the Euler-Bernoulli theory (L3)
CO3	Summarize the deflection of beams and concept of torsion (L3)
CO4	Illustrate principles of virtual work different energy methods (L3)
CO5	Comprehend the basics of fatigue, creep and fracture (L3)



18.	1SJ18AE019	GIRISH N	10	10	10	10	9	9	9	48	28
19.	1SJ18AE020	GOWTHAM S	ABSENT								
20.	1SJ18AE021	HARSHA D S	8				8				
21.	1SJ18AE022	HARSHITH L	10	4				10	10	35	21
22.	1SJ18AE023	HARSHITHA K	10	7				6	8	41	16
23.	1SJ18AE024	HEMANTH B S	10	9			10		10	49	24
24.	1SJ18AE025	JANAPAREDDI SAIKUMAR	8	2	7			4	9	30	18
25.	1SJ18AE026	K KEERTHIVARDHAN	10	10				10	10	50	30
26.	1SJ18AE027	KOLLANA YESWANTH	10		2				7	28	16
27.	1SJ18AE028	MAHIMA T S	10	7				10	10	47	28
28.	1SJ18AE029	MANIKYA G	10	7				10	10	47	28
29.	1SJ18AE030	MANJESH KUMAR K P	10	7				10	10	47	28
30.	1SJ18AE031	MANOJ S	ABSENT								
31.	1SJ18AE032	MANOJ SINGH H	10	4				10	10	30	18
32.	1SJ18AE033	MARIYAMBI T S	10	10				9	10	49	29
33.	1SJ18AE034	MEGHASHREE M S	10	9				8	8	45	27
34.	1SJ18AE035	MOHAMMED AZAM	10	3					9	40	24
35.	1SJ18AE036	MONIKA CHAVAN A	8		8				9	36	22
36.	1SJ18AE037	MYTHRI C	10						8	37	22
37.	1SJ18AE038	NAGAMANI J V	10	7				3	8	38	23
38.	1SJ18039	NAGESH DR	5	10					10	45	27
39.	1SJ18AE040	PRAJAKTA S LOKHANDE	10	10				9	7	46	28
40.	1SJ18AE041	PRAMODGOWDA T S	6					2	9	28	17
41.	1SJ18AE042	PRASAD BELGUNDKAR	10	6				9	10	45	27
42.	1SJ18AE043	RACHANA J							5	17	11
43.	1SJ18AE044	RAHUL P	5		2			9	10	28	16
44.	1SJ18AE045	RAKESH S	10	5				6	8	39	23



|| Jai Sri Gurudev ||  
**S.J.C. Institute of Technology, Chickballapur**  
**Department of Aeronautical Engineering**  
**Rubrics-II**

**Subject: Mechanics of Materials**

**Subject code: 18AE33**

Sl. No.	USN	NAME OF THE STUDENT	A	B	C	D	Total
1	1SJ18AE001	ABDUL RAHMAN J	3	1	3	1	8
2	1SJ18AE002	AFRIN TAJ P M	A	A	A	A	A
3	1SJ18AE003	AKASH M	4	1	3	1	9
4	1SJ18AE004	AKASH SIDDANGOUDA PATIL	4	1	3	1	9
5	1SJ18AE005	AKSHAY KUMAR P S	A	A	A	A	A
6	1SJ18AE006	ANNASAGARAM GOWTHAMI	3	1	3	2	9
7	1SJ18AE007	ANUSHREE N	4	1	3	1	9
8	1SJ18AE008	ARAVIND R NAIDU	3	1	3	1	8
9	1SJ18AE009	ARJI BHARATH	3	1	3	1	8
10	1SJ18AE010	BHASKAR S	A	A	A	A	A
11	1SJ18AE011	BHAVANA A J	4	1	4	1	10
12	1SJ18AE012	BINDUSHREE K	4	1	3	1	9
13	1SJ18AE013	CHANDAN KUMAR A	A	A	A	A	A
14	1SJ18AE014	CHAVALI BHIMA SANKARAM	2	1	2	1	6
15	1SJ18AE015	CHIDANANDA	4	1	3	1	9
16	1SJ18AE016	DHANUSH KUMAR B K	4	1	3	1	9
17	1SJ18AE017	DURGAPRASAD N S	3	1	3	2	9
18	1SJ18AE018	GIRIDHAR S	2	1	3	2	8
19	1SJ18AE019	GIRISH N	3	1	4	1	9
20	1SJ18AE020	GOWTHAM S	A	A	A	A	A
21	1SJ18AE021	HARSHA D S	3	1	4	1	9
22	1SJ18AE022	HARSHITH L	3	1	3	3	10
23	1SJ18AE023	HARSHITHA K	4	1	3	1	9
24	1SJ18AE024	HEMANTH B S	3	2	4	1	10
25	1SJ18AE025	JANAPAREDDI SAIKUMAR	3	1	2	1	7

26	1SJ18AE026	K KEERTHIVARDHAN	4	1	4	1	10
27	1SJ18AE027	KOLLANA YESWANTH	4	1	3	1	9
28	1SJ18AE028	MAHIMA T S	3	1	3	1	8
29	1SJ18AE029	MANIKYA G	3	1	4	1	9
30	1SJ18AE031	MANOJ S	4	2	2	1	9
31	1SJ18AE032	MANOJ SINGH H	3	1	4	1	9
32	1SJ18AE033	MARIYAMBI T S	3	1	3	1	8
33	1SJ18AE034	MEGHASHREE M S	3	1	3	3	10
34	1SJ18AE035	MOHAMMED AZAM	3	1	3	1	8
35	1SJ18AE036	MONIKA CHAVAN A	3	1	3	1	8
36	1SJ18AE037	MYTHRI C	4	1	3	1	9
37	1SJ18AE038	NAGAMANI J V	4	1	2	1	8
38	1SJ18AE039	NAGESH D R	3	1	4	1	9
39	1SJ18AE040	PRAJAKTA S LOKHANDE	3	1	3	1	8
40	1SJ18AE041	PRAMODGOWDA T S	3	1	4	2	10
41	1SJ18AE042	PRASAD BELGUNDKAR	3	1	4	1	9
42	1SJ18AE043	RACHANA J	3	1	3	1	8
43	1SJ18AE044	RAHUL P	4	1	3	1	9
44	1SJ18AE045	RAKESH S	4	1	3	1	9
45	1SJ18AE046	RAMYAKRISHNA K	4	1	3	1	9
46	1SJ18AE047	RANJITH B S	A	A	A	A	A
47	1SJ18AE048	RAVINDRA SREE CHENDAN SAI	4	1	2	1	8
48	1SJ18AE049	SAI KEERTHAN B L	3	1	2	1	7
49	1SJ18AE050	SAMPRUTHA A R	4	1	3	1	9
50	1SJ18AE051	SOWBHAGYA M R	4	1	3	2	10
51	1SJ18AE052	SRIDHAR K R	4	1	3	2	10
52	1SJ18AE053	UJWAL N	4	1	3	1	9
53	1SJ18AE054	UMESH RANA	4	1	3	1	9
54	1SJ18AE055	USHA G	4	1	2	1	8
55	1SJ18AE056	VAISHAK M	4	1	2	1	8
56	1SJ18AE057	VARUN M	1	1	1	1	4
57	1SJ18AE058	VEERESH	4	1	3	1	9
58	1SJ18AE059	VIGNESH GOWDA P	1	1	3	1	6
59	1SJ18AE060	YASHWANTH R	2	1	3	1	7

60	1SJ18AE061	YASHWANTH S	4	1	3	1	9
61	1SJ18AE062	YASHWANTH T H	3	1	3	1	8
62	1SJ18AE063	YOGESH E S	A	A	A	A	A
63	1SJ18AE064	NARINDER KUMAR	4	1	2	1	8
64	1SJ18AE0	MOHAN REDDY	4	1	3	1	9

A = Description for the answer B = Figures or Diagrams C = Numericals and derivations  
D = Timely submission

*Bing*  
25/11/11



**DEPARTMENT: AERONAUTICAL ENGINEERING**

**Scheme & Solutions- TEST- I/II/III**

**Date: 12/10/19**

**Semester: III**

**Subject Title: Mechanics of Materials Subject Code: 18AE33**

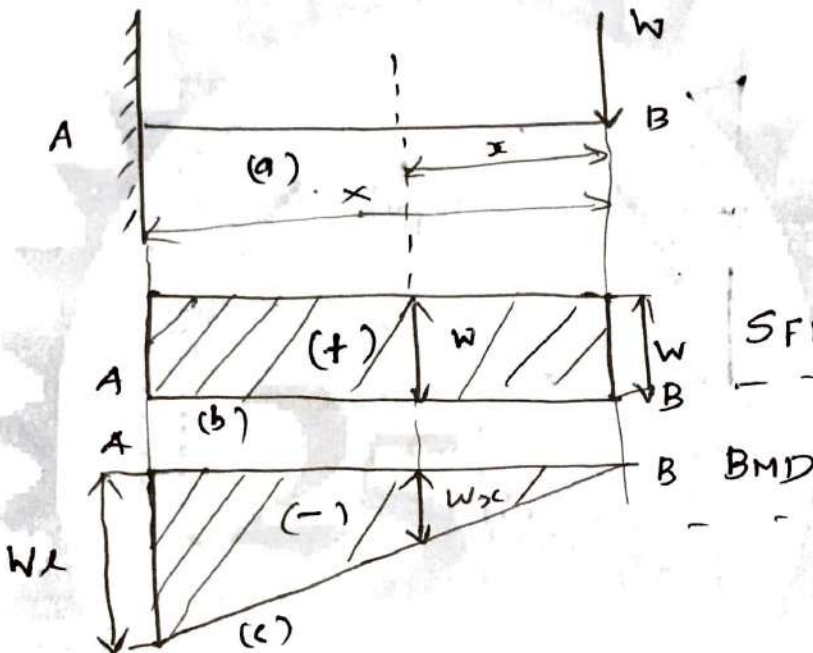
Question Number	Solution	Marks Allocated
1.)	<p style="text-align: center;"><u>Cantilever Beam with Point load</u></p>  <p>Shear force <math>F_x = +W</math></p> <p>S.F at B = <math>+W</math></p> <p>SF at A = <math>+W</math></p> <p>Bending moment</p> <p>B.M at B = 0</p> <p>B.M at A = <math>-Wl</math></p> <p style="text-align: right;">Full steps</p>	<p style="text-align: center;">01</p> <hr/> <p style="text-align: center;">01</p> <hr/> <p style="text-align: center;">01</p> <hr/> <p style="text-align: center;">01</p>

Subject Title: MoM

Subject Code: 18AE32

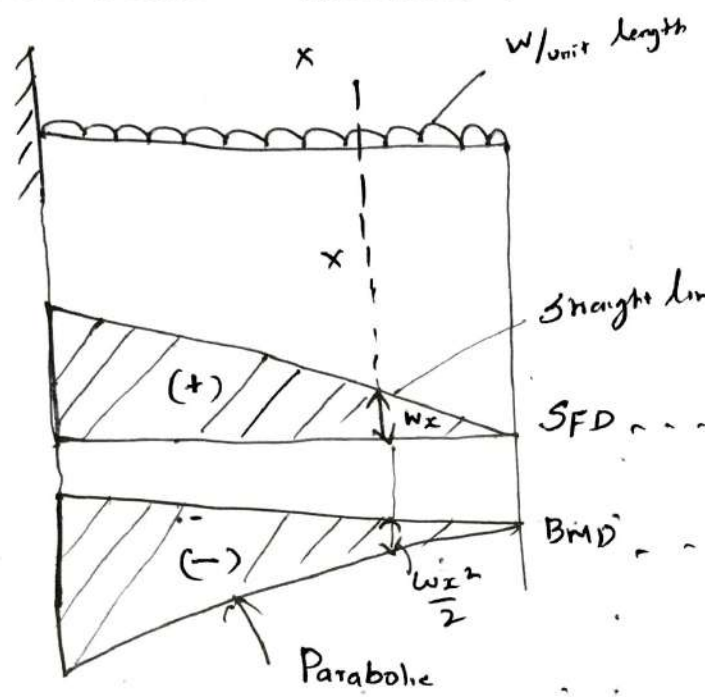
Question Number	Solution	Marks Allocated
	<p><u>Cantilever Beam with UDL</u></p>  <p style="text-align: right;">w/unit length</p> <p style="text-align: center;">x</p> <p style="text-align: center;">x</p> <p style="text-align: right;">Straight line</p> <p>SFD ..... 01</p> <p>BMD ..... 01</p> <p style="text-align: right;"><math>w x</math></p> <p style="text-align: right;"><math>\frac{w x^2}{2}</math></p> <p style="text-align: center;">Parabolic</p> <p><math>F = +wx</math> ..... 01</p> <p><u>Shear force</u></p> <p>S.F at B = 0</p> <p>S.F at A = <math>+wl</math> ..... 01</p> <p><u>Bending moment</u></p> <p>BM at B = 0</p> <p>BM at A = <math>-\frac{wl^2}{2}</math> ..... 01</p>	



Subject Title: MOM

Subject Code: 18AE33

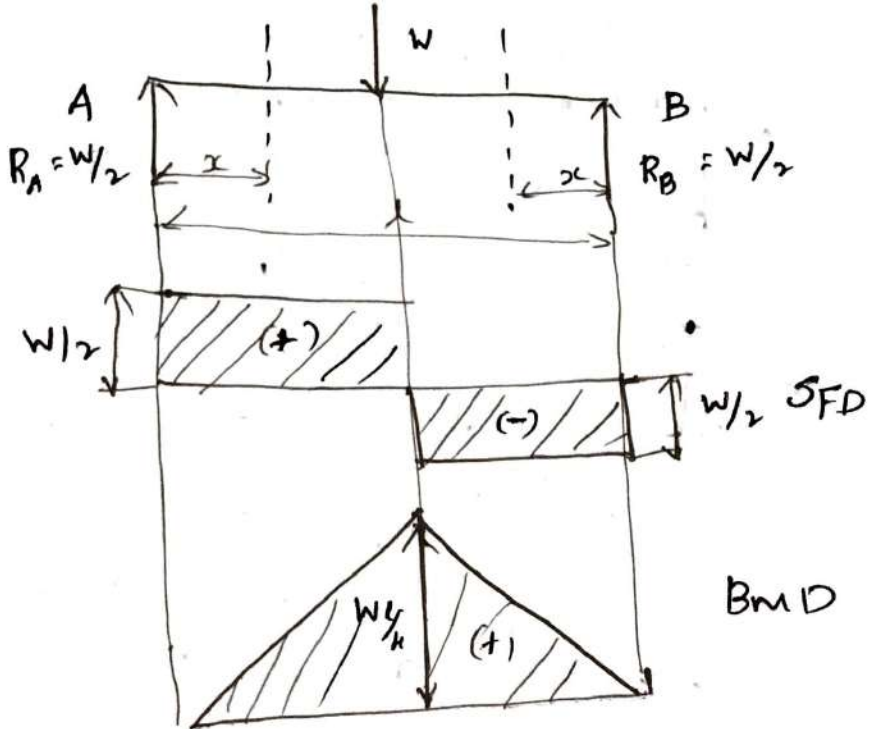
Question Number	Solution	Marks Allocated
2.)	<p><u>Simply Support Beam With Point load</u></p>  <p><math>R_A = R_B = W/2</math></p> <p>(i) <u>Considers the portion BC</u>  S.F at B = <math>-W/2</math>  B/w B &amp; C, SF = <math>-W/2</math>  BM at Section <math>x-x = +W/2 x</math>  BM at B = 0  BM at C = <math>+wl/4</math></p> <p>(ii) <u>Considers the portion AC</u>  S.F A &amp; C = <math>+W/2</math>  B.M = <math>+W/2 x</math>  B.M at B = 0, BM at C = <math>+wl/4</math></p>	<p>01</p> <p>01</p> <p>01</p> <p>01</p>



Subject Title: MOM

Subject Code: 18AE3

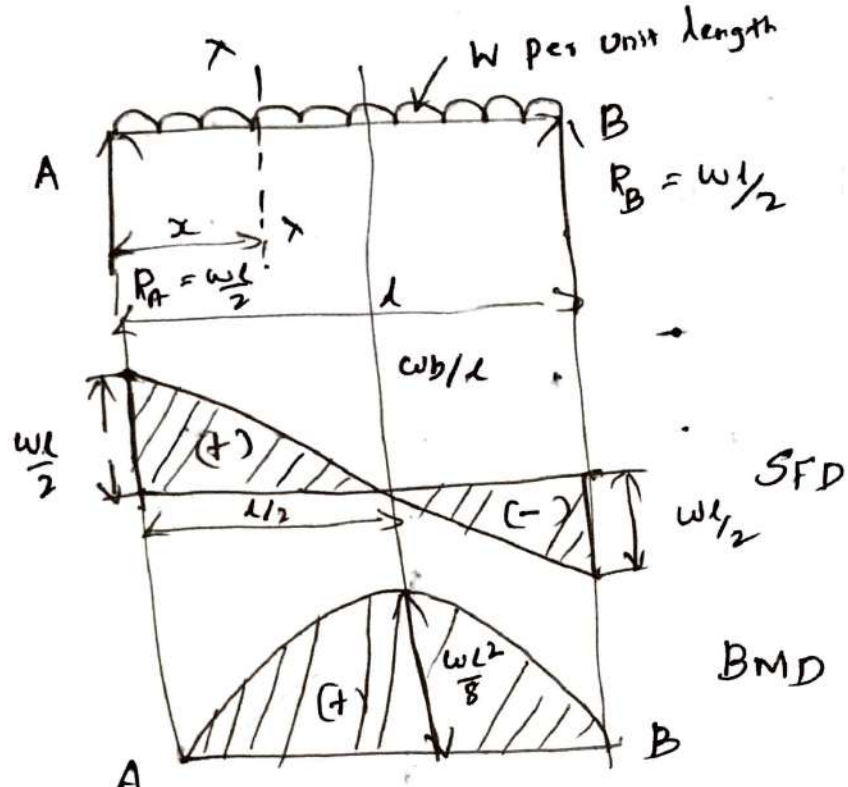
Question Number	Solution	Marks Allocated
	<p><u>Simply Supported Beam with UDL</u></p>  <p><u>Shear Force</u></p> <p>S.F at A = <math>+wl/2</math></p> <p>SF at C = 0</p> <p>SF at B = <math>-wl/2</math></p> <p><u>Bending moment</u></p> <p>B.M at A = 0</p> <p>B.M at C = <math>wl^2/8</math></p> <p>B.M at B = 0</p> <p>Steps</p>	<p>01</p> <p>01</p> <p>01</p> <p>01</p>

Subject Title: MOM

Subject Code: 18AE33

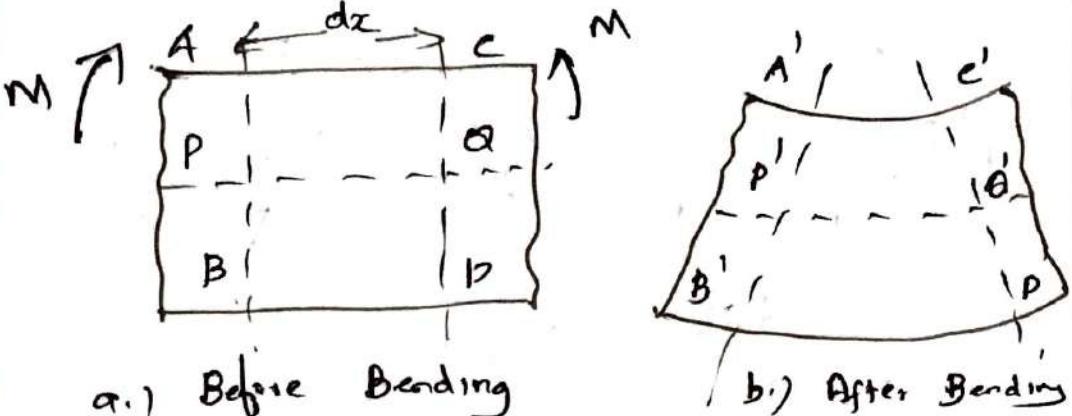
Question Number	Solution	Marks Allocated
3.)	<p data-bbox="211 414 682 492"><u>Bending Equation</u></p>  <p data-bbox="266 862 689 940">a.) Before Bending</p> <p data-bbox="909 862 1238 940">b.) After Bending</p> <p data-bbox="297 996 1191 1086">Strain in the layers <math>\epsilon = \frac{y}{R}</math> ...</p> <p data-bbox="415 1108 697 1209"><math>\sigma = \frac{E \cdot y}{R}</math></p> <p data-bbox="509 1243 697 1366"><math>\therefore \frac{\sigma}{y} = \frac{E}{R}</math> ...</p> <p data-bbox="321 1388 1207 1489">Stress on the element <math>= \sigma = \frac{E \cdot y}{R}</math> ...</p> <p data-bbox="384 1489 838 1590">Force <math>= \frac{E}{R} \cdot y \cdot \delta a</math> ...</p> <p data-bbox="399 1601 940 1702">M.I NA <math>= \frac{E}{R} y^2 \delta a</math></p> <div data-bbox="384 1747 854 1937" style="border: 1px solid black; padding: 5px; display: inline-block;"> <math display="block">\frac{M}{I} = \frac{\sigma}{y} = \frac{E}{R}</math> </div> <p data-bbox="188 1960 1215 2139">The above equation is called Bernoulli-Euler Bending Equation</p>	<p data-bbox="1332 728 1442 784">02</p> <p data-bbox="1285 1008 1379 1064">01</p> <p data-bbox="1317 1232 1442 1288">02</p> <p data-bbox="1332 1422 1434 1478">01</p> <p data-bbox="1324 1534 1434 1590">02</p> <p data-bbox="1340 1803 1458 1859">02</p>



Subject Title:

MOM

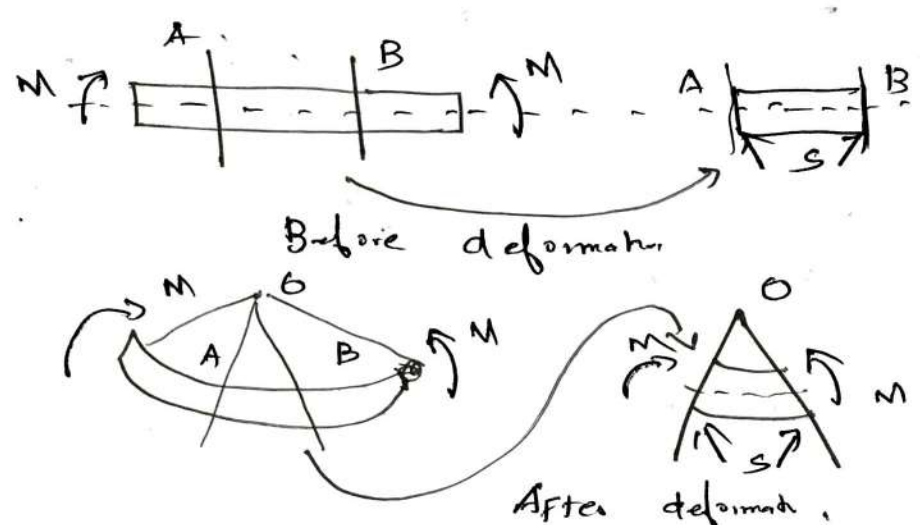
Question Number	Solution	Marks Allocated
4.)	<p data-bbox="319 302 1037 383"><u>Euler - Bernoulli Assumptions</u></p>  <p data-bbox="303 1008 590 1088"><u>Implications</u></p> $u_1(x_1, x_2, x_3) = \hat{u}_1(x) + x_3 \phi_2(x) - x_2 \phi_3(x)$ $\phi_3 = \frac{d\hat{u}_3}{dx_1}, \quad \phi_2 = -\frac{d\hat{u}_3}{dx_1}$ <p data-bbox="973 1814 1228 1895"><u>Explanation</u></p>	<p data-bbox="1340 504 1468 564">02</p> <p data-bbox="1324 786 1452 846">02</p> <p data-bbox="1340 987 1452 1048">01</p> <p data-bbox="1388 1310 1500 1370">02</p> <p data-bbox="1372 1552 1516 1612">02</p> <p data-bbox="1388 1814 1468 1874">01</p>



Subject Title: MOM

Subject Code: 18AE33

Question Number	Solution	Marks Allocated
5.)	<p><u>SFD and BMD</u></p> <p>SFD</p> <p>BMD</p> <p>Shear Force Diagram</p> <p>SF at B = +20 kN</p> <p>SF at D = +30 kN</p> <p>SF at C = 69 kN</p> <p>SF at A = 69 kN</p>	<p>02</p> <p>02</p> <p>01</p> <p>01</p> <p>01</p>



Subject Title: MOM

Subject Code: 18AE33

Question Number	Solution	Marks Allocated
-----------------	----------	-----------------

Bending Moment Diagram

BM at B = 0

BM at D = -20 kNm

BM at C = -10 kNm

BM at A = -173 kNm

01

01

01

6.) SFD and BMD

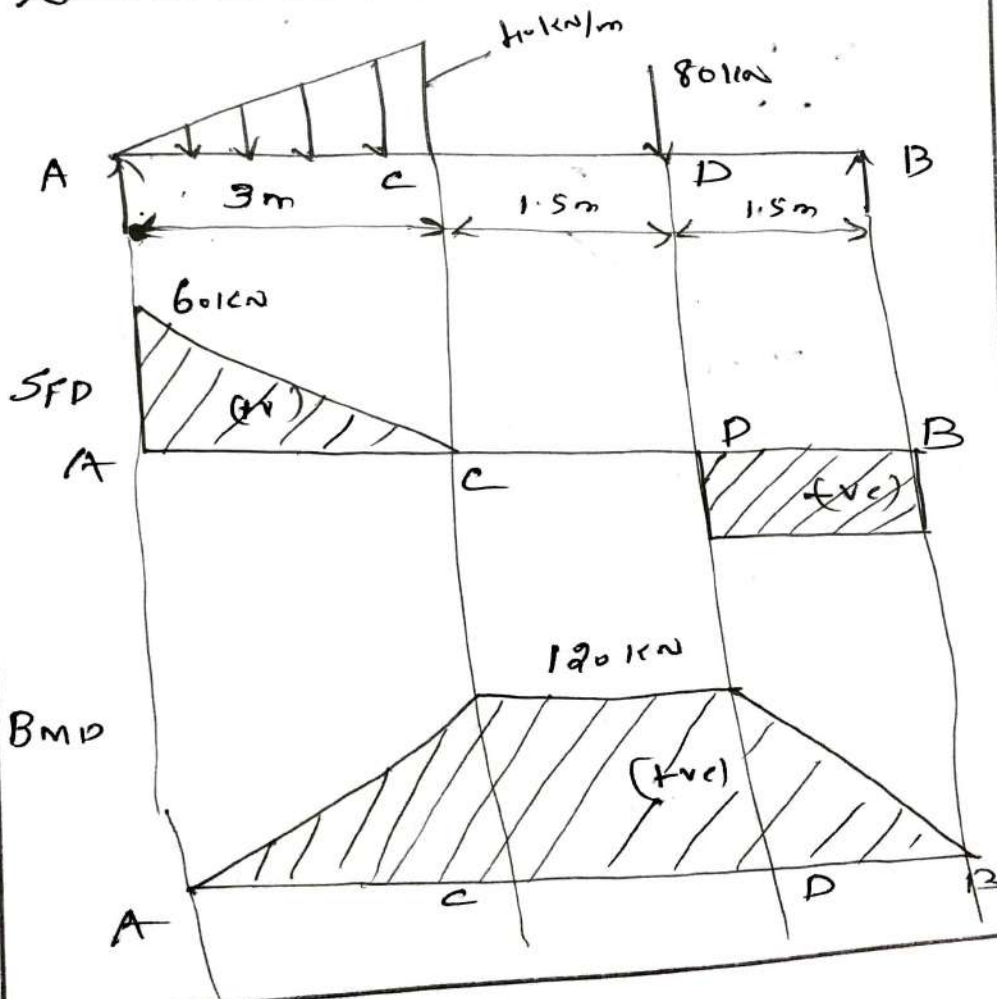

02

02



Subject Title: M O M

Subject Code: 18AE33

Question Number	Solution	Marks Allocated
	<p> <math>\sum M_B = 0</math>  <math>R_A = 60 \text{ kN}</math>  <math>R_B = 80 \text{ kN}</math> </p> <p> <u>Portion AC</u>            Load intensity = <math>\frac{20x^2}{3}</math>            S.F at A = 60 kN            SF at C = 0            BM at A = 0 (x=0)            BM at C = 120 kNm (x=3m)         </p> <p> <u>Portion CD</u>  <math>F = 0</math>  <math>M = 80x - 80(x - 1.5)</math>  <math>M = 120 \text{ kNm}</math> (x=0)         </p> <p> <u>Portion DB</u>  <math>F = -80 \text{ kN}</math>  <math>M = 80x</math>  <math>M = 0</math> (x=0)  <math>M = 120 \text{ kNm}</math> (x=1.5m)         </p>	<p>01</p> <p>01</p> <p>01</p> <p>01</p> <p>01</p> <p>01</p>



Subject Title: MOM

Subject Code: 18AE33

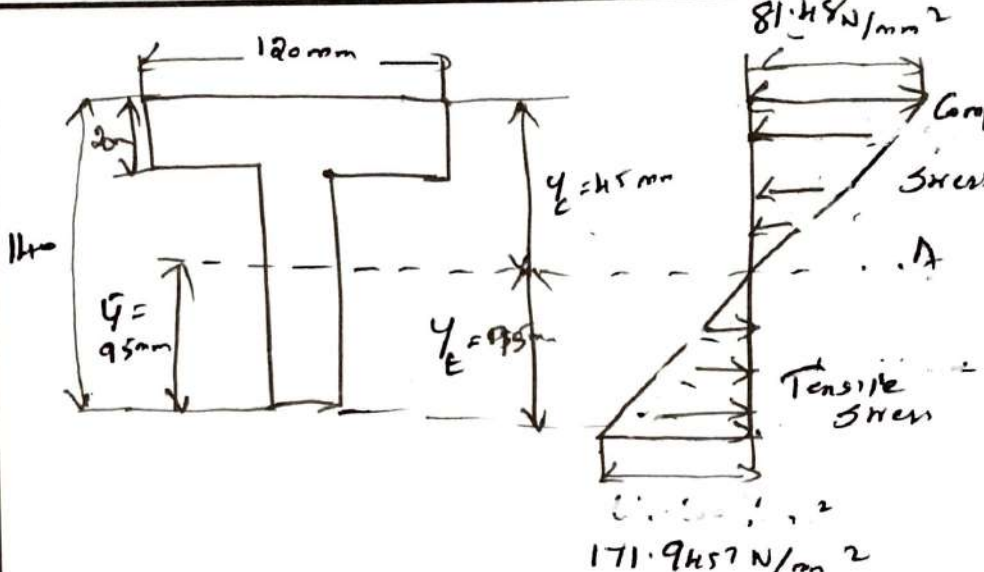
Question Number	Solution	Marks Allocated
7.)	 <p>Soln</p> <p>For SSB, <math>M = \frac{wL^2}{8} = 16 \text{ kNm}</math></p> <p><math>y_c = 45 \text{ mm}, y_e = 95 \text{ mm}</math></p> <p><math>I = I_1 + I_2</math></p> <p><math>I_1 = 5.82 \times 10^6 \text{ mm}^4</math></p> <p><math>I_2 = 8.84 \times 10^6 \text{ mm}^4</math></p> <p>Bending stress in the top layer</p> $\sigma_c = \frac{M}{I} y_{c \max}$ $= 81.488 \text{ N/mm}^2 \text{ (Compressive)}$ <p>Bending stress in the bottom layer</p> $\sigma_t = 171.9457 \text{ N/mm}^2 \text{ (Tensile)}$	<p>02</p> <p>02</p> <p>01</p> <p>01</p> <p>02</p> <p>02</p>

Subject Title:

Mom

Subject Code: 18AE33

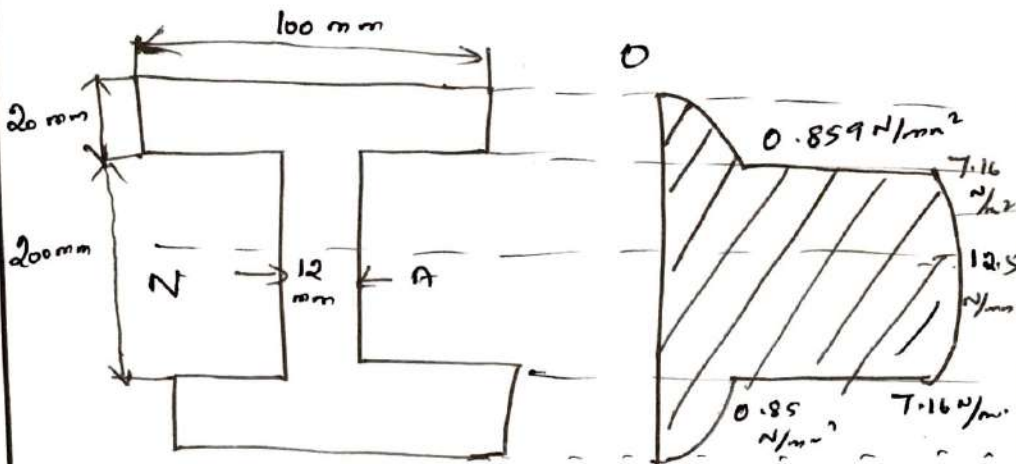
Question Number	Solution	Marks Allocated
8.)	 <p>Moment of Inertia <math>I_{\text{inertia}} = BD^3 - bd^3</math>  <math>= 56.3 \times 10^6 \text{ mm}^4</math></p> <p><math>I_{\text{TF}} = 0</math></p> <p>Shear Stress at <math>\left(\frac{I}{BF}\right) = 0.859 \text{ N/mm}^2</math></p> <p><math>I = \frac{F}{Ib} \times Ay</math></p> <p>Shear Stress at Junction b/w flange &amp; web</p> <p><math>I = 0.859 \times B/b</math>  <math>= 7.16 \text{ N/mm}^2</math></p> <p>Shear Stress at NA,</p> <p><math>Ay = 280,000 \text{ mm}^2</math></p>	<p>02</p> <p>02</p> <p>01</p> <p>01</p> <p>01</p> <p>01</p> <p>01</p>



Subject Title: MOM

Subject Code: 18AE33

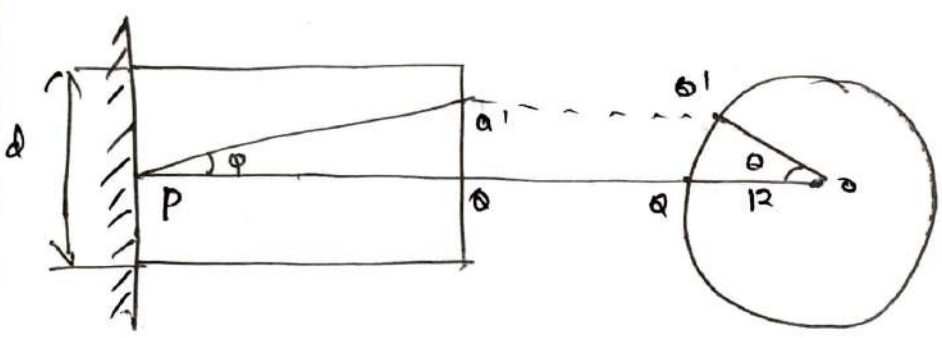
Question Number	Solution	Marks Allocated
	<p>∴ Maximum shear stress at NA</p> $\tau = \frac{F}{I_b} \times Ay$ $= \frac{200}{56.3 \times 10^4 \times 12} \times 280,000$ $= 12.5 \text{ N/mm}^2$	01
9.)	<p><u>Torsional Equation</u></p>  <p>Shear strain at outer surface</p> $\phi = \frac{\theta R}{\lambda}$ $\therefore \phi = \frac{R\theta}{\lambda}$	02 01 01

Subject Title: MOM

Subject Code: 18AE33

Question Number	Solution	Marks Allocated
	$\phi_1 = \frac{\tau \theta}{l}$	
	$\frac{T}{R} = \frac{G \theta}{l} \dots \dots \dots (i) \dots$	01
	$\therefore \frac{T}{R} = \frac{G \theta}{l} = \frac{\tau}{\gamma} \dots \dots \dots (ii) \dots$	01
	$\text{Area} = \delta a = 2\pi r \cdot dr$	
	$\delta F = \frac{T}{R} \cdot 2\pi r^2 dr \dots \dots$	01
	$\text{Total Torque} = \frac{\pi d^4}{32} \cdot \frac{T}{R}$	
	$\therefore \frac{T}{J_p} = \frac{T}{R} \left[ J_p = \frac{\pi d^4}{32} \right] \dots$	01
	$\boxed{\frac{T}{J_p} = \frac{T}{R} = \frac{G \theta}{l}} \dots \dots \dots$	02
	<p>The above equation is known as Torsional Equation.</p>	
10.)	<p><u>Solution</u></p> <p>Power Transmitted <math>N = \frac{2\pi N T_{mean}}{60,000}</math> kW</p> <p><math>T_{mean} = 79577.5 \times 10^3 \text{ Nmm}</math></p> <p><math>T_{max} = 1.25 \times T_{mean} = 99.472 \times 10^6 \text{ Nmm}</math></p>	01 01 01



Subject Title: MOM

Subject Code: 18AE33

Question Number	Solution	Marks Allocated
	<p>i.) <u>Solid Circular Shaft</u></p> $\frac{T}{J_p} = \tau / r$ $T = \frac{\pi}{16} d^3 \cdot \tau$ <p>∴ Diameter of shaft <math>d = 185 \text{ mm}</math></p>	<p>01</p> <p>01</p>
	<p>(ii) <u>Hollow Circular Shaft</u></p> $T_s = T_H$ <p><math>d_o = 193.76</math> (outer dia)</p> <p><math>d_i = 116.26</math> (inner dia)</p>	<p>01</p> <p>01</p> <p>01</p>
	<p>(iii) <u>Percentage Saving in material</u></p> <p>Weight = Volume <math>\times</math> density weight of the material</p> $\% \text{ saving} = \frac{W_s - W_H}{W_s} \times 100$ $= 29.76 \%$	<p>02</p>
	<p>Binu 12/10/19 Staff in charge</p> <p>(V Rajan) 12/10/19 Reviewer</p> <p>(V Rajan) 12/10/19 HOD</p>	



Internal Test Question paper

Name of the staff/s: Dr. BINO PRINCE RAJA.D

Date: 18/11/2019

Signature:

*Bino*  
18/11/19

Reviewer's Signature:

*[Signature]*  
20/11/19

**S.J.C. Institute of Technology**  
**Department of Aeronautical Engineering**  
**Test: III Semester: III**

**Subject Name & Code: Mechanics of Materials - 18AE33**

**Date: 27/11/2019**

**Time: 9.30-12.30**

**Max Marks: 100**

**NOTE: 1. Answer all the questions. Missing datas can be suitably assumed.**

Question Number		Marks	CO	Levels
1	a) Derive Equilibrium equation of 3D stress system.	10	CO1	L-3
	b) Derive Compatibility Equation	10	CO1	L-3
<b>OR</b>				
2	a) Derive the equation for Bars with continuously varying Cross sections with i) Rectangular Cross section ii) Circular Cross section	10	CO1	L-3
	b) Derive the Stresses on an inclined Plane corresponding to i) Uniaxial stresses ii) Biaxial Stresses	10	CO1	L-3
3	a) Derive the equation for Cantilever beam with Point load and UDL	10	CO2	L-3
	b) Derive the equation for Simply supported beam with Point load and UDL	10	CO2	L-3
<b>OR</b>				
4	a) The simply supported beam shown in the figure carries two concentrated loads and a uniformly distributed load. Draw the SFD and BMD.	10	CO2	L-3

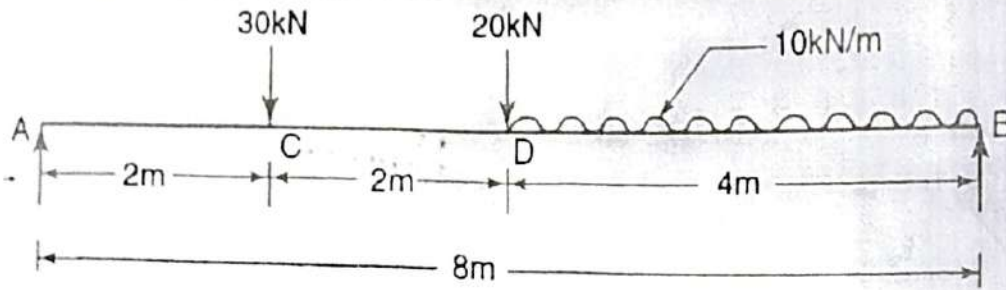

(a) Space Diagram

b) The T section shown in the figure below is used for a simply supported beam over a span of 4m. It carries a uniformly distributed load of 8kN/m over its entire span. Calculate the maximum tensile and compressive stresses occurring in the section .

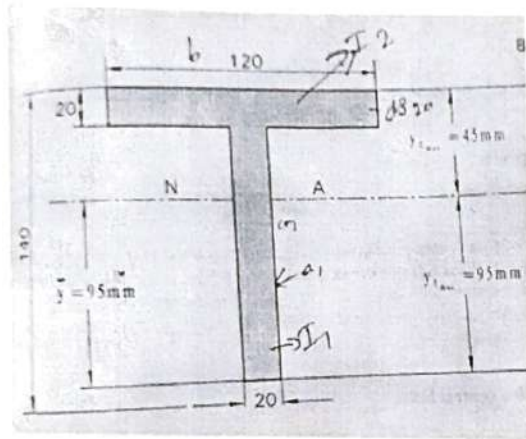

10 CO2 L-3

a) Derive the Deflection of a cantilever beam with point load

5

10 CO3 L-3

b) A cantilever beam 2m long A cantilever beam 2m long and rectangular in cross-section of 100\*200mm wide and deep respectively carries a udl and a point load as shown in the below figure . find the deflection of the beam at the free end . Take  $E = 1 \cdot 10^5 \text{ N/mm}^2$ .

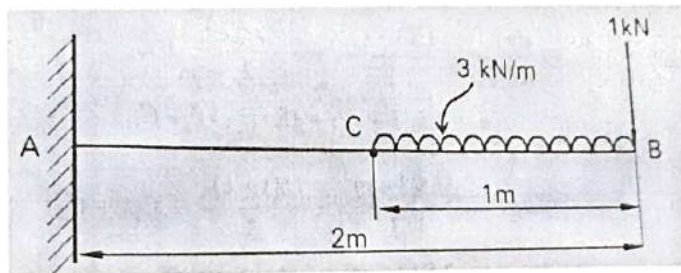

10 CO3 L-3



## OR

6	a) Derive the deflection of Simply supported beam with uniformly distributed load .	10	C03	L-3
	b) Derive the deflection of Simply supported beam with point load at centre.	10	C03	L-3
7	a) Define conservative forces and obtain the work done by conservative force along any path joining two points .	10	C04	L-3
	b) Explain a) Clapeyron's theorem b) Maxwell's theorem c) Castiglione's theorem	10	C04	L-3

## OR

8	a) Define principle of virtual work for a particle. Obtain the equilibrium of a particle.	10	C04	L-3
	b) Explain the steps involved in unit load method applied to TRUSS structures.	10	C04	L-3
9	a) Define fracture. Explain the classification of fracture.	10	C05	L-3
	b) Define fatigue. Explain types of fatigue loading.	10	C05	L-2

## OR

10	a) Explain the SN diagram in fatigue.	10	C05	L-3
	b) Define creep and explain the stages of creep deformation.	10	C05	L-2

**COURSE OUTCOMES:**

**On successful completion of this course, students should be able to**

<b>C01</b>	Apply the concepts of equations of linear elasticity corresponding to stress and strain (L3)
<b>C02</b>	Draw the Shear force and Bending Moment diagrams, and Study the Euler-Bernoulli theory (L3)
<b>C03</b>	Summarize the deflection of beams and concept of torsion (L3)
<b>C04</b>	Illustrate principles of virtual work different energy methods (L3)
<b>C05</b>	Comprehend the basics of fatigue, creep and fracture (L3)

**//JAI SRI GURUDEV//**  
**S.J.C INSTITUTE OF TECHNOLOGY**  
**DEPARTMENT OF AERONAUTICAL ENGINEERING**  
**Mechanics of Materials (18AE33)**

**Tutorials-III**

Sl. No.	Questions	CO	Levels
<b>MODULE-IV</b>			
1.	Define conservative forces and obtain the work done by conservative force along any path joining two points .	CO4	L3
2.	Explain a) Clapeyron's theorem b) Maxwell's theorem c) Castiglione's theorem	CO4	L3
3.	Derive the work potential equation due to body force, surface force and point load.	CO4	L3
4.	Derive the equation for Strain energy in Springs.	CO4	L3
5.	Derive the equation for Strain energy in Beams and solids.	CO4	L3
6.	Define principle of virtual work for a particle. Obtain the equilibrium of a particle.	CO4	L3
7.	Explain the steps involved in unit load method applied to TRUSS structures.	CO4	L3
8.	What are the difference between the principle of virtual work and the principle of complementary?	CO4	L3
9.	Explain the steps involved in unit load method applied to BEAMS.	CO4	L3
<b>MODULE-V</b>			
10.	Define fracture and explain the classification of fracture.	CO5	L3
11.	Define fatigue and explain types of fatigue loading.	CO5	L2
12.	Explain the stages of fatigue failure.	CO5	L2
13.	Explain the SN diagram in fatigue.	CO5	L3
14.	List the fatigue properties.	CO5	L2
15.	List the factors affecting the fatigue.	CO5	L2
16.	Define creep and explain the stages of creep deformation.	CO5	L2
17.	Explain stress relaxation.	CO5	L3
<b>MODULE-III</b>			
18.	Derive the Differential equation for deflection curve.	CO3	L3
19.	Derive the Deflection of a Cantilever beam with a point load at the free end .	CO3	L3
20.	Derive the Deflection of a cantilever beam with point load	CO3	L3
21.	Derive the Deflection of a Cantilever beam with an uniformly distributed load .	CO3	L3
22.	Derive the Deflection of a Cantilever beam with uniformly varying load zero at the free end and w/unit length at the fixed end .	CO3	L3

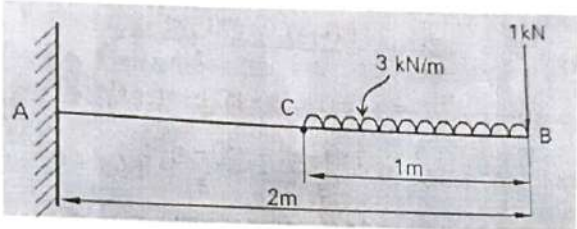
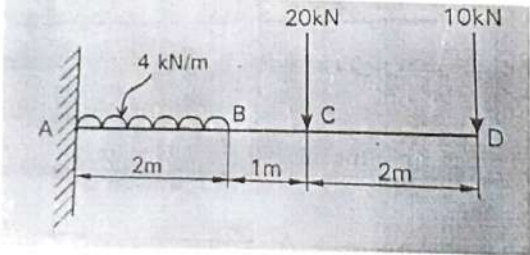
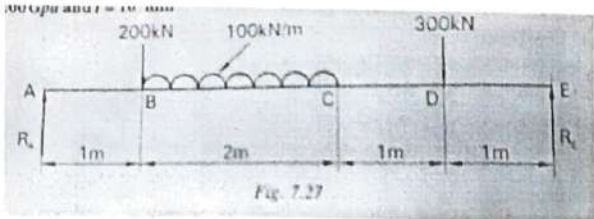
23.	Derive the Deflection of a cantilever beam with couple or moment at the free end .	CO3	L3
24.	Derive the deflection of Simply supported beam with uniformly distributed load .	CO3	L3
25.	Derive the deflection of Simply supported beam with point load at centre.	CO3	L3
26.	Derive the deflection of Simply supported beam with uniformly varying load.	CO3	L3
27.	A cantilever beam 2m long A cantilever beam 2m long and rectangular in cross-section of 100*200mm wide and deep respectively carries a udl and a point load as shown in the below figure . find the deflection of the beam at the free end .Take $E = 1 \cdot 10^5 \text{ N/mm}^2$ .	CO3	L3
			
28.	A Cantilever beam is 150 mm wide , 200 mm deep and of 2m span carries a uniformly varying load of 50 KN/m at the free end to 150 KN/m at the fixed end . find the slope and deflection of the Cantilever beam at the free end .Take $E = 1 \cdot 10^8 \text{ kN/m}^2$ .	CO3	L3
29.	A Cantilever beam 2 m long of 20kN at its free end and 30kN at a distance of 1 m from the free end . find the slope and deflection at the free end . take $I = 15 \cdot 10^7 \text{ mm}^4$ , $E = 2 \cdot 10^5 \text{ N/mm}^2$	CO3	L3
30.	Find the slope and deflection at the free end of the cantilever shown in the below figure $E = 200 \text{ kN/mm}^2$ ; $I = 40 \cdot 10^6 \text{ mm}^4$ .	CO3	L3
			
31.	A simply supported beam is loaded as shown in the below figure . Determine the deflection at point B,C and D take $E = 200 \text{ Gpa}$ and $I = 10^9 \text{ mm}^4$ .	CO3	L3
	 <p style="text-align: center;">Fig. 7.27</p>		
32.	A simply supported steel beam having a uniform cross-section is 14m span and is simply supported at its ends. It carries a concentrated load of 120kN and 80kN at two points 3m and 4.5 m from the left and right end respectively . If the	CO3	L3

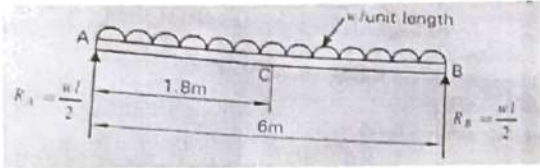
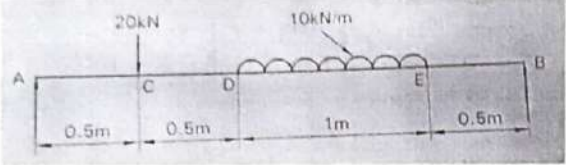
	moment of inertia of the section is $160 \times 10^7 \text{ mm}^4$ and $E = 210 \text{ GPa}$ , calculate the deflection of the beam at load points and mid span.		
33.	A beam of uniform cross-section 6m long is simply supported at its ends. It is loaded at points 2m from each end with a load of 50kN . Find the ratio of maximum deflection to the deflection at the point under one of the loads . also calculate the slopes at the supports.	CO3	L3
34.	A steel girder of 6m length acting as a beam carries a udl $w \text{ N/m}$ run through of its length as shown in the below figure if $I = 30 \times 10^6 \text{ m}^4$ and depth 270 mm calculate ; * magnitude of $w$ so that the maximum stress developed in the beam section does not exceed $72 \text{ MN/m}^2$ . The slope of the deflection in the beam at a distance of 1.8m from one end . Take $E = 200 \text{ GN/m}^2$ .	CO3	L3
			
37	Determine the maximum deflection and its location in the beam as shown in the below figure the beam has a cross-section of 40mm wide*100mm deep. $E = 2 \times 10^5 \text{ N/mm}^2$ .	CO3	L3
			
39	A horizontal beam AB is freely supported at A and B, 8m apart , and carries a uniformly distributed load of 15 kN/m . A clock wise moment of 160kNm is applied to the beam at a point c,3m from the left hand support A . calculate <ul style="list-style-type: none"> <li>• Slope of the beam at C.</li> <li>• Deflection of the beam at C.</li> <li>• Maximum deflection .Take the flexural rigidity as 40 MN-m<sup>2</sup></li> </ul>	CO3	L3

Bing  
17/11/19

*(Signature)*  
(V Rajan)  
20/11/19.

**PROFESSOR & HEAD**  
Department of Aeronautical Engineering  
S.J.C. Institute of Technology  
CHICKBALLAPUR-562101

|| Jai Sri Gurudev ||  
**S.J.C. Institute of Technology, Chickballapur**  
**Department of Aeronautical Engineering**  
**Rubrics-III**

**Subject: Mechanics of Materials**

**Subject code: 18AE33**

Sl. No.	USN	NAME OF THE STUDENT	A	B	C	D	Total
1	1SJ18AE001	ABDUL RAHMAN J	4	1	4	1	10
2	1SJ18AE002	AFRIN TAJ P M	A	A	A	A	A
3	1SJ18AE003	AKASH M	4	1	3	2	10
4	1SJ18AE004	AKASH SIDDANGOUDA PATIL	4	1	4	1	10
5	1SJ18AE005	AKSHAY KUMAR P S	A	A	A	A	A
6	1SJ18AE006	ANNASAGARAM GOWTHAMI	3	1	3	3	10
7	1SJ18AE007	ANUSHREE N	4	1	3	2	10
8	1SJ18AE008	ARAVIND R NAIDU	3	1	3	3	10
9	1SJ18AE009	ARJI BHARATH	4	1	3	2	09
10	1SJ18AE010	BHASKAR S	A	A	A	A	A
11	1SJ18AE011	BHAVANA A J	4	1	4	1	10
12	1SJ18AE012	BINDUSHREE K	4	1	4	1	10
13	1SJ18AE013	CHANDAN KUMAR A	A	A	A	A	A
14	1SJ18AE014	CHAVALI BHIMA SANKARAM	4	1	4	1	10
15	1SJ18AE015	CHIDANANDA	4	1	3	2	10
16	1SJ18AE016	DHANUSH KUMAR B K	4	1	3	2	10
17	1SJ18AE017	DURGAPRASAD N S	3	1	3	3	10
18	1SJ18AE018	GIRIDHAR S	4	1	3	1	9
19	1SJ18AE019	GIRISH N	3	1	4	2	10
20	1SJ18AE020	GOWTHAM S	A	A	A	A	A
21	1SJ18AE021	HARSHA D S	4	1	3	1	9
22	1SJ18AE022	HARSHITH L	3	1	3	3	10
23	1SJ18AE023	HARSHITHA K	4	1	4	1	10
24	1SJ18AE024	HEMANTH B S	3	1	3	3	10
25	1SJ18AE025	JANAPAREDDI SAIKUMAR	4	1	4	1	10

26	1SJ18AE026	K KEERTHIVARDHAN	4	1	4	1	10
27	1SJ18AE027	KOLLANA YESWANTH	4	1	4	1	10
28	1SJ18AE028	MAHIMA T S	4	1	4	1	10
29	1SJ18AE029	MANIKYA G	4	1	4	1	10
30	1SJ18AE031	MANOJ S	4	1	3	1	9
31	1SJ18AE032	MANOJ SINGH H	3	1	4	2	10
32	1SJ18AE033	MARIYAMBI T S	4	1	4	1	10
33	1SJ18AE034	MEGHASHREE M S	3	1	3	3	10
34	1SJ18AE035	MOHAMMED AZAM	3	1	4	2	10
35	1SJ18AE036	MONIKA CHAVAN A	3	1	3	3	10
36	1SJ18AE037	MYTHRI C	4	1	3	2	10
37	1SJ18AE038	NAGAMANI J V	4	1	3	2	10
38	1SJ18AE039	NAGESH D R	3	1	4	2	10
39	1SJ18AE040	PRAJAKTA S LOKHANDE	3	1	4	2	10
40	1SJ18AE041	PRAMODGOWDA T S	3	1	3	3	10
41	1SJ18AE042	PRASAD BELGUNDKAR	3	1	4	2	10
42	1SJ18AE043	RACHANA J	3	1	4	2	10
43	1SJ18AE044	RAHUL P	4	1	4	1	10
44	1SJ18AE045	RAKESH S	4	1	3	2	10
45	1SJ18AE046	RAMYAKRISHNA K	4	1	3	2	10
46	1SJ18AE047	RANJITH B S	A	A	A	A	A
47	1SJ18AE048	RAVINDRA SREE CHENDAN SAI	4	1	3	2	10
48	1SJ18AE049	SAI KEERTHAN B L	4	1	3	1	9
49	1SJ18AE050	SAMPRUTHA A R	4	1	3	2	10
50	1SJ18AE051	SOWBHAGYA M R	4	1	3	2	10
51	1SJ18AE052	SRIDHAR K R	4	1	3	1	9
52	1SJ18AE053	UJWAL N	4	1	3	2	10
53	1SJ18AE054	UMESH RANA	4	1	3	2	10
54	1SJ18AE055	USHA G	4	1	3	2	10
55	1SJ18AE056	VAISHAK M	4	1	3	2	10
56	1SJ18AE057	VARUN M	4	1	3	2	10
57	1SJ18AE058	VEERESH	4	1	3	2	10
58	1SJ18AE059	VIGNESH GOWDA P	4	1	3	1	9
59	1SJ18AE060	YASHWANTH R	4	1	3	2	10

60	1SJ18AE061	YASHWANTH S	4	1	3	2	10
61	1SJ18AE062	YASHWANTH T H	4	1	3	2	10
62	1SJ18AE063	YOGESH E S	A	A	A	A	A
63	1SJ18AE064	NARINDER KUMAR	4	1	3	2	10
64	1SJ18AE0	MOHAN REDDY	4	1	3	2	10

**A = Description for the answer B = Figures or Diagrams C = Numericals and derivations  
D = Timely submission**

*Bid*  
05/11/2017

**DEPARTMENT: AERONAUTICAL ENGINEERING**

**Scheme & Solutions- TEST- I/II/III**

Date: 21/11/19

Semester: III

Subject Title: Mechanics of Materials Subject Code: 18AE33

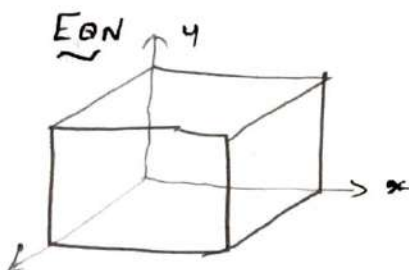
Question Number	Solution	Marks Allocated
1 a.)	<p><u>EQUILIBRIUM</u> <u>EON</u></p>  <p>Considering the Normal and Shear stress acting in x-direction (Force Equilibrium)</p> $\frac{\partial \sigma_x}{\partial x} + \frac{\partial \tau_{yx}}{\partial y} + \frac{\partial \tau_{zx}}{\partial z} + X = 0$ $\frac{\partial \sigma_y}{\partial y} + \frac{\partial \tau_{zy}}{\partial z} + \frac{\partial \tau_{xy}}{\partial x} + Y = 0$ $\frac{\partial \sigma_z}{\partial z} + \frac{\partial \tau_{xz}}{\partial x} + \frac{\partial \tau_{yz}}{\partial y} + Z = 0$ <p><u>Moment Equilibrium</u></p> $\tau_{xy} = \tau_{yx}$ $\tau_{xz} = \tau_{zx}$ $\tau_{yz} = \tau_{zy}$	01  02 02 02  01 01 01
b.)	<p><u>Compatibility Equation</u></p> $\epsilon_x = \frac{\partial u}{\partial x}, \quad \epsilon_y = \frac{\partial v}{\partial y}, \quad \epsilon_z = \frac{\partial w}{\partial z}$ $\gamma_{xy} = \frac{\partial u}{\partial y} + \frac{\partial v}{\partial x}$ $\gamma_{yz} = \frac{\partial v}{\partial z} + \frac{\partial w}{\partial y}$ $\gamma_{xz} = \frac{\partial w}{\partial x} + \frac{\partial u}{\partial z}$	02  02



Subject Title:

MOM

Subject Code:

18AE33

Question Number	Solution	Marks Allocated
	$2 \frac{\partial^2 \epsilon_x}{\partial x \partial y} = \frac{\partial}{\partial x} \left[ \frac{\partial v_{yz}}{\partial z} - \frac{\partial v_{xz}}{\partial y} + \frac{\partial v_{xy}}{\partial z} \right]$	02
	$2 \frac{\partial^2 \epsilon_y}{\partial x \partial z} = \frac{\partial}{\partial y} \left[ \frac{\partial v_{yz}}{\partial z} - \frac{\partial v_{zx}}{\partial y} + \frac{\partial v_{xy}}{\partial z} \right]$	02
	$2 \frac{\partial^2 \epsilon_z}{\partial x \partial y} = \frac{\partial}{\partial z} \left( \frac{\partial v_{yz}}{\partial x} + \frac{\partial v_{xz}}{\partial y} - \frac{\partial v_{xy}}{\partial z} \right)$	02
2 a.)	<p>(i) <u>Rectangular Cross Section</u></p> <p>Rate of change of breadth is <math>\frac{b_1 - b_2}{L}</math></p> $A = t(b_1 - kx)$ $\text{Extension} = \frac{P dx}{(b_1 - kx)tE}$ <p>Total extension of bar is</p> $= \frac{P}{tE} \int_0^L \frac{dx}{b_1 - kx}$ $= \frac{PL}{tE(b_1 - b_2)} \log \frac{b_1}{b_2}$	01 01 01 02
	<p>(ii) <u>Circular cross section</u></p> $k = \frac{d_1 - d_2}{L}$ $A = \frac{\pi}{4} (d_1 - kx)^2$ $\text{Extension of element} = \frac{P dx}{\frac{\pi}{4} (d_1 - kx)^2 E}$ $\text{Extension of the bar} = \int_0^L \frac{P dx}{\frac{\pi}{4} (d_1 - kx)^2 E}$	01 01 01

Subject Title:

MOM

Subject Code: 18AE33

Question Number	Solution	Marks Allocated
	$\Delta = \frac{4PL}{\pi E d^3}$ <p>Uniform bar = <math>\frac{PL}{\frac{\pi}{4} d^3 E}</math></p> <p>Tapering rod = <math>\frac{d^3 PL}{\pi E d^3}</math></p>	<p>01</p> <p>01</p>
<p>b.)</p>	<p>1.) <u>Uniaxial Stresses</u></p> <p><math>\sum</math> forces normal to DE = 0</p> $P_n = P \cos^2 \theta \quad \text{--- (1)}$ <p><math>\sum</math> forces parallel to DE = 0</p> $P_t = P/2 \sin 2\theta \quad \text{--- (2)}$ <p>From (1), <math>P_n</math> is max, when <math>\theta = 0</math></p> <p>From (2), <math>P_t</math> is max, <math>2\theta = 90^\circ</math>, <math>\theta = 45^\circ</math></p>	<p>02</p> <p>02</p> <p>01</p>
	<p>(ii) <u>Biaxial Stresses</u></p> $P_n = P_1 \cos^2 \theta + P_2 \sin^2 \theta$ $P_t = \frac{P_1 - P_2}{2} \sin 2\theta$ $R = \sqrt{P_n^2 + P_t^2}$ $\tan \phi = \frac{P_n}{P_t}$	<p>02</p> <p>02</p> <p>01</p>



Subject Title: MOM

Subject Code: 18AE3

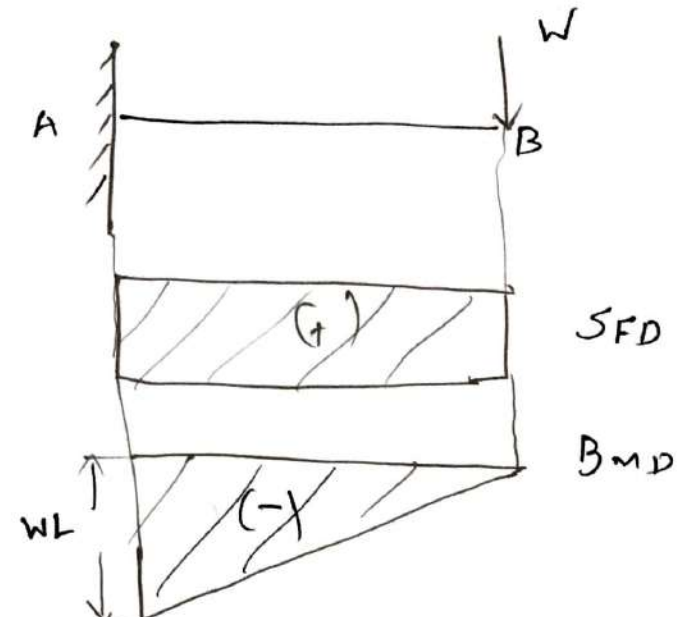
Question Number	Solution	Marks Allocated
3 a.)	<p style="text-align: center;"><u>Cantilever Beam with Point load</u></p>  <p style="text-align: center;"><math>F_{sc} = +W</math></p> <p><u>Shear Force</u></p> <p style="text-align: center;">S.F at B = +W S.F at A = +W</p> <p><u>Bending moment</u></p> <p style="text-align: center;">B.M at B = 0 B.M at A = -WL</p>	<p style="text-align: center;">01</p> <p style="text-align: center;">01</p> <p style="text-align: center;">01</p> <p style="text-align: center;">01</p> <p style="text-align: center;">04</p>

Subject Title: Mom

Subject Code: 18AE33

Question Number	Solution	Marks Allocated
	<p><u>Cantilever Beam with UDL</u></p> <p style="text-align: right;">SFD</p> <p style="text-align: right;">BMD</p> <p style="text-align: center;"><math>F = +wx</math></p> <p><u>Shear Force</u></p> <p>S.F at B = 0</p> <p>S.F at A = <math>-wl</math></p> <p><u>Bending Moment</u></p> <p>B.m at B = 0</p> <p>B.m at A = <math>-\frac{wl^2}{2}</math></p>	<p>01</p> <p>01</p> <p>01</p> <p>01</p> <p>01</p> <p>01</p>



Subject Title: MOM

Subject Code: 18AE3

Question Number	Solution	Marks Allocated
b.)	<p><u>Simply Supported Beam with Point load</u></p> <p><math>R_A = R_B = W/2</math></p> <p>i.) <u>Consider the portion BC</u></p> <p>S.F at B = <math>-W/2</math>          SF at B &amp; c = <math>-W/2</math>          BM at B = 0          BM at c = <math>+Wl/4</math></p> <p>ii.) <u>Consider the portion AC</u></p> <p>S.F A &amp; c = <math>+W/2</math>          B.M = <math>+W/2 x</math>          B.M at B = 0          B.M at c = <math>+Wl/4</math></p>	<p>0  </p> <p>0  </p> <p>0  </p> <p>0  </p>



Subject Title: MOM

Subject Code: 18AE33

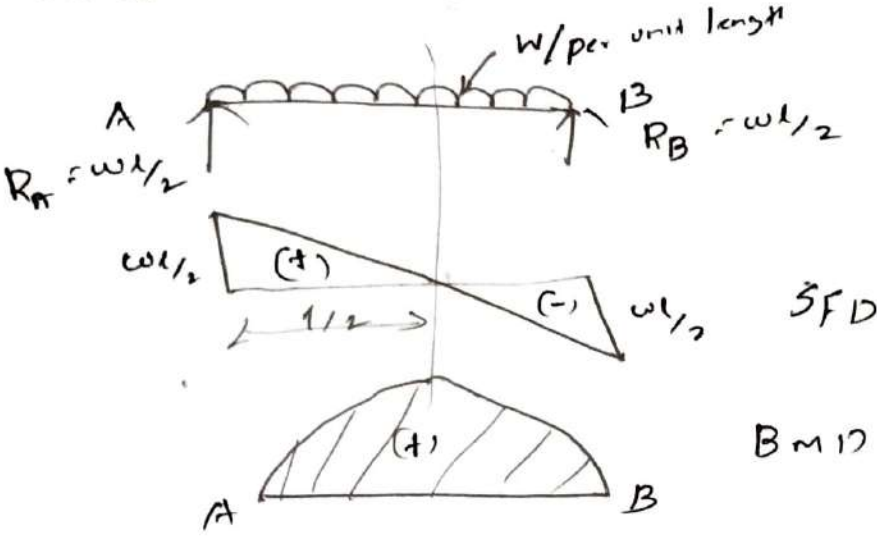
Question Number	Solution	Marks Allocated
	<p><u>Simply supported with UDL</u></p>  <p><u>Shear Force</u></p> <p>S.F at A = <math>+wl/2</math></p> <p>S.F at C = 0</p> <p>SF at B = <math>-wl/2</math></p> <p><u>Bending moment</u></p> <p>B.M at A = 0</p> <p>B.M at C = <math>wl^2/8</math></p> <p>B.M at B = 0</p>	<p>01</p> <p>01</p> <p>01</p> <p>01</p> <p>01</p>



Subject Title: MOM

Subject Code: 18AE33

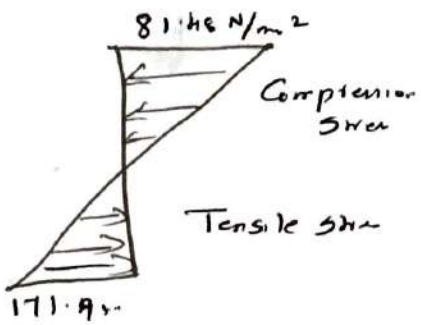
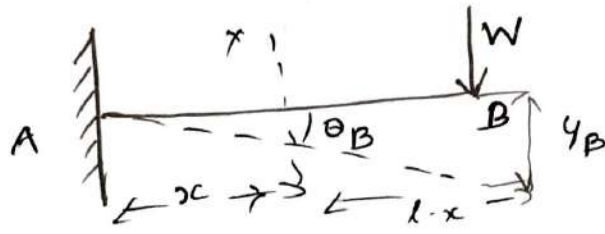
Question Number	Solution	Marks Allocated
b.)	<p>For SSB, <math>M = \frac{wl^2}{8} = 16 \text{ kNm}</math> } ...</p> <p><math>y_c = 45 \text{ mm}, y_t = 95 \text{ mm}</math></p> <p><math>I_1 = 5.82 \times 10^6 \text{ mm}^4, I_2 = 8.84 \times 10^6 \text{ mm}^4</math></p> <p>Bending stress in the top layer:</p> $\sigma_c = \frac{M}{I} \cdot y_{c,max} = 81.488 \text{ N/mm}^2 \text{ (C)}$ <p>Bending stress in the bottom layer:</p> $\sigma_t = 171.957 \text{ N/mm}^2 \text{ (T)}$ 	<p>02</p> <p>02</p> <p>02</p> <p>02</p> <p>02</p>
5 a.)	<p><u>Deflection of cantilever beam with point load</u></p>  <p><math>C_1 = -\frac{wl^2}{2}</math></p> <p><math>\theta_B = \frac{wl^2}{2EI}</math></p> <p><math>C_2 = \frac{wl^3}{6}</math></p> <p><math>y_B = \frac{wl^3}{3EI}</math></p>	<p>02</p> <p>02</p> <p>02</p> <p>02</p>



Subject Title: Mom

Subject Code: 181

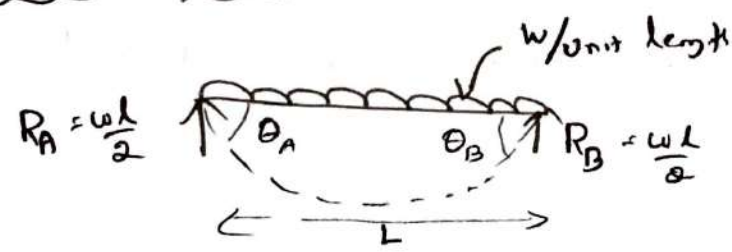
Question Number	Solution	Marks Allocated
b.)	<p>Slope at free end due to UDL = <math>\frac{30.5}{EI}</math> radian</p> <p>Slope at free end due to 3kN = <math>\frac{13.5}{EI}</math> radian</p> <p>Total slope = <math>44 \times 10^{-3}</math> radian</p> <p>Slope at free end <math>\theta_B = 44 \times 10^{-3}</math> radian</p> <p>Deflection at free end due to UDL = <math>\frac{166.375}{EI}</math></p> <p>Deflection at free end due to 3kN = <math>\frac{54 \text{ mm}}{EI}</math></p> <p><math>y_B = 0.0160375 \text{ m}</math></p>	<p>02</p> <p>02</p> <p>02</p> <p>02</p> <p>02</p>
6 a.)	<p><u>Deflection of SSB with UDL</u></p>  <p><math>C_2 = 0</math></p> <p><math>C_1 = \frac{wL^3}{6}</math></p> <p><math>\theta_A = -\frac{wL^3}{24EI}</math></p> <p><math>\theta_B = \frac{wL^3}{24EI}</math></p> <p><math>y_{max} = \frac{5}{384} \frac{wL^4}{EI}</math></p>	<p>02</p> <p>02</p> <p>02</p> <p>02</p>

Subject Title: MoM

Subject Code: 18AE33

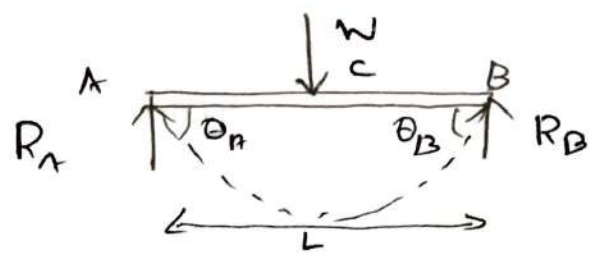
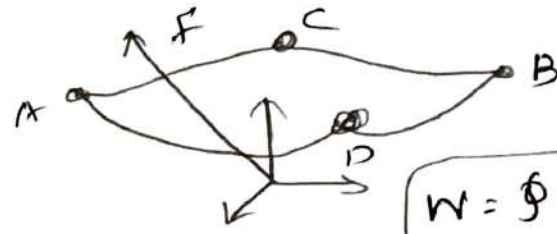
Question Number	Solution	Marks Allocated
b.)	<p><u>Deflection of SSB with load at centre</u></p>  <p> <math>R_A = R_B = \frac{WL}{2}</math>  <math>C_2 = 0</math>  <math>C_1 = -\frac{WL^2}{16}</math>  <math>\theta_A = -\frac{WL^2}{16EI}</math>  <math>\theta_B = \frac{WL^2}{16EI}</math>  <math>y_c = \frac{WL^3}{48EI}</math> </p>	<p>02</p> <p>02</p> <p>02</p> <p>02</p> <p>02</p>
7a.)	<p><u>Conservative Forces</u></p> <p>If and only if the work it performs along any path joining the same initial and final point is identical.</p> <p> <math>W = \int_{\text{Path ACB}} F \cdot ds = \int_{\text{Path ADB}} F \cdot ds</math> </p>  <p> <math>W = \oint F \cdot ds = \oint_c F \cdot ds</math> </p>	<p>02</p> <p>02</p> <p>02</p> <p>04</p>



Subject Title:

MOM

Subject Code: 18AE33

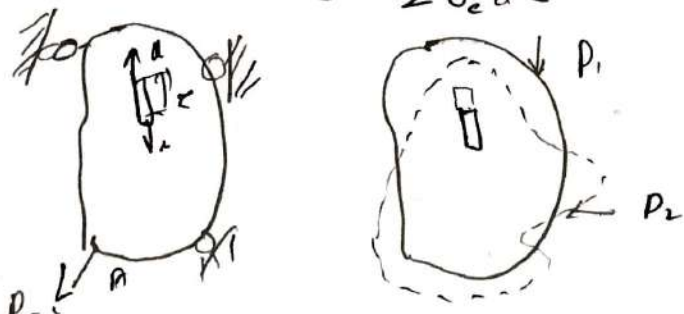
Question Number	Solution	Marks Allocated
b.)	<p>i.) <u>Clapeyron's thm</u></p> $\text{Strain energy} = \sum_{i=1}^n \frac{P_i \times \Delta_i}{2} \dots$ <p>(ii) <u>Castiglione's thm</u>      <u>Statement</u> . . .</p> $\frac{\partial U_i}{\partial \delta_i} = P_i \dots$ <p><u>Statement</u> . . .</p> <p>(iii) <u>Maxwell theorem</u></p> $\delta_{AB} = \delta_{BA} \dots$ <p><u>Statement</u> . . .</p>	<p>02</p> <p>01</p> <p>02</p> <p>01</p> <p>02</p> <p>02</p>
8 a.)	<p><u>Principle of Virtual Work for a Particle</u></p> <p>This Principle is based on law of Conservation of energy. Whenever a body is fixed from moving, it is necessary to loading satisfy the equilibrium conditions of displacements.</p> $U_e = U_i$ $\sum P \Delta = \sum U \delta$ $\Delta = \sum U \cdot dL$ $J. \theta = \sum U_e dL \dots$	<p>02</p> <p>02</p> <p>02</p> <p>02</p>
		<p>02</p>

Subject Title: Mom

Subject Code: 18AE33

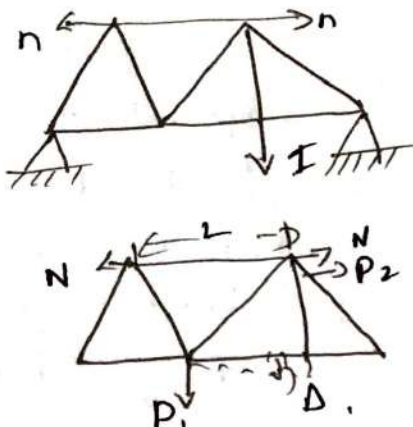
Question Number	Solution	Marks Allocated
b.)	 <p> <math display="block">I \cdot \Delta = \int_0^L \frac{nN}{AE} dx = \frac{nNL}{AE} \quad \text{--- (1)}</math> <math display="block">I \cdot \Delta = \frac{2}{3} \frac{nNL}{AE} \quad \text{--- (2)}</math> </p>	<p>02</p> <p>02</p> <p>03</p> <p>03</p>
9 a.)	<p><u>Fracture</u></p> <p>Fracture is the separation or fragmentation of a solid body into two or more parts under the action of load.</p> <ol style="list-style-type: none"> <li>1.) Ductile Fracture             <ol style="list-style-type: none"> <li>a.) Highly ductile fracture</li> <li>b.) Moderately ductile fracture</li> </ol> </li> <li>2.) Brittle Fracture</li> <li>3.) Shear Failure</li> </ol> <p><u>Explanation</u> - ...</p>	<p>02</p> <p>02</p> <p>02</p> <p>02</p> <p>02</p>



Subject Title: MOM

Subject Code: 18AE33

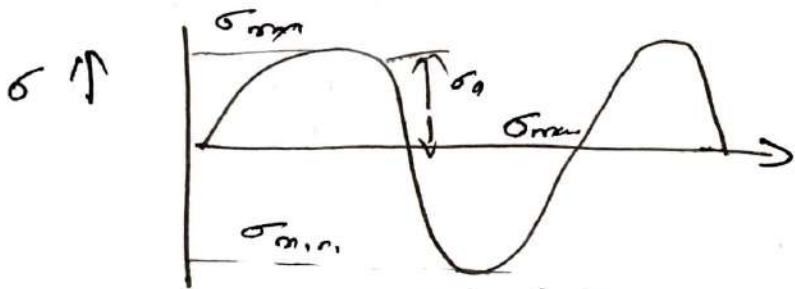
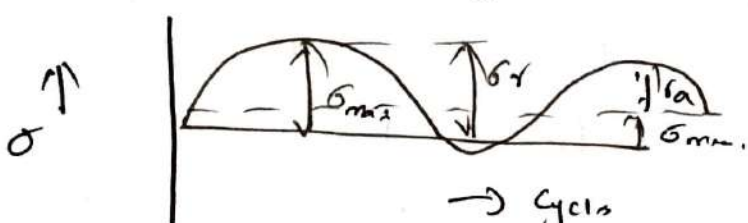
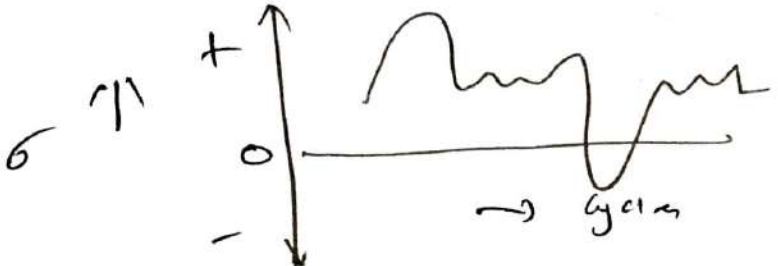
Question Number	Solution	Marks Allocated
b.7)	<p><u>Fatigue</u></p> <p>Materials subjected to fluctuating or repeated loads tend to show a behaviour which is different from steady loading condition. This behaviour is known as "Fatigue behaviour".</p> <p>1.) Completely reversed cycle stress</p>  <p>2.) Repeated stress cycles</p>  <p>3.) Irregular or Random stress cycle</p>  <p>Explanation ...</p>	<p>02</p> <p>02</p> <p>02</p> <p>02</p>

Subject Title: MOM

Subject Code: 18AE33

Question Number	Solution	Marks Allocated
10 a.)	<p><u>S-N Diagram</u></p> <p>Stress (S) ↑</p> <p>Mild Steel</p> <p>Al Alloy</p> <p>Endurance limit</p> <p>→ No. of Cycles</p> <p>Explanation . . .</p>	06
b.)	<p><u>Creep</u></p> <p>The slow and progressive deformation of a material with time at constant stress.</p> <p>3 stages</p> <ol style="list-style-type: none"> <li>① Primary Creep . . . . .</li> <li>② Secondary Creep . . . . .</li> <li>③ Tertiary Creep . . . . .</li> </ol> <p>Explanation of above . . .</p>	04 02 02 02 02

By 21/11/19  
Staff incharge

21/11/19  
Reviewer

(V Rajan)  
PROFESSOR & HEAD  
Department of Aeronautical Engineering  
S.J.C. Institute of Technology  
CHICKBALLUR



Name of the staff: Dr. BINO PRINCE RAJA.D

Subject: Mechanics of Materials

Sub code: 18AE33

Semester: III

Mapping of CO matrix with Test- Question Papers (IA-3)

Sl.No	USN	Name	CO's										Total Marks 100	Total Marks 30
			CO 1	CO 2	CO 3	CO 4	CO 5	CO 6	CO 7	CO 8	CO 9	CO 10		
Max Marks			10	2	2	12	2	36						11
Q.No			ABSENT											
1.	1SJ18AE001	ABDUL RAHMAN J	10	10	2	12	2	36						11
2.	1SJ18AE002	AFRIN TAJ P M	ABSENT											
3.	1SJ18AE003	AKASH M	2	8	6	39						16		
4.	1SJ18AE004	AKASH SIDDANGOURA PATIL	10	18	3	51	20						16	
5.	1SJ18AE006	ANNASAGARAM GOWTHAMI	20	20	17	18	18	93	18					28
6.	1SJ18AE007	ANUSHREE N	20	20	16	15	20	91	20					28
7.	1SJ18AE008	ARAVIND R NAIDU	20	16	9	15	15	60	18					18
8.	1SJ18AE009	ARJI BHARATH	9	10	20	18	51	17						17
9.	1SJ18AE010	BHASKAR S	ABSENT											
10.	1SJ18AE011	BHAVANA A J	20	20	20	20	20	100	30					30
11.	1SJ18AE012	BINDUSHREE K	20	13	16	18	85	26						26
12.	1SJ18AE013	CHANDAN KUMAR A	ABSENT											
13.	1SJ18AE014	CHAVALI BHIMA SANKARAM	20	20	20	20	20	100	30					30
14.	1SJ18AE015	CHIDANANDA	20	5	9	11	45	14						14
15.	1SJ18AE016	DHANUSH KUMAR B K	10	15	7	9	41	13						13
16.	1SJ18AE017	DURGAPRASAD N S	19	18	4	18	79	24	20					24
17.	1SJ18AE018	GIRIDHAR S	20	10	4	34	11						11	



18.	1S18AE019	GIRISH N	20	20	20	20	20	20	20	20	20	100	30
19.	1S18AE020	GOWTHAM S	ABSENT										18
20.	1S18AE021	HARSHA D S		10	12	6	18					51	18
21.	1S18AE022	HARSHITH L	20	19	4	10	2					61	19
22.	1S18AE023	HARSHITHA K	20	19	16	20	20					95	29
23.	1S18AE024	HEMANTH B S		20	20	20	20				20	100	30
24.	1S18AE025	JANAPAREDDI SAIKUMAR		18		19	19					56	17
25.	1S18AE026	K KEERTHIVARDHAN	10	16	14	5	20					65	20
26.	1S18AE027	KOLLANA YESWANTH	20	18	10	10	20					68	21
27.	1S18AE028	MAHIMA T S	13	17	19	19				20		69	21
28.	1S18AE029	MANIKYA G	20	20	20	20	20					100	30
29.	1S18AE030	MANJESH KUMAR K P	ABSENT										
30.	1S18AE031	MANOJ S	9	6		20	9					44	14
31.	1S18AE032	MANOJ SINGH H	10	17	5					9		41	13
32.	1S18AE033	MARIYAMBIT S		20		10	20					70	21
33.	1S18AE034	MEGHASHREE M S	10	20	9	16	18	18				73	22
34.	1S18AE035	MOHAMMED AZAM	10		12	6	10					46	14
35.	1S18AE036	MONIKA CHAVAN A	13	18	14	6	20					71	22
36.	1S18AE037	MYTHRIC		10	12					18		70	21
37.	1S18AE038	NAGAMANI J V	19	18	8	16				10		71	22
38.	1S18039	NAGESH DR		10	20	20	20					90	27
39.	1S18AE040	PRAJAKTA S LOKHANDE		20	7	6	10					50	15
40.	1S18AE041	PRAMODGOWDA T S		16	18	16	15					63	20
41.	1S18AE042	PRASAD BELGUNDKAR		20	20	20	20					97	30
42.	1S18AE043	RACHANA J	18	10	7					12		47	15
43.	1S18AE044	RAHUL P		10	10	20	18			18		58	18
44.	1S18AE045	RAKESH S	20	20	12	18				8		78	24



*Handwritten signature/initials*

	15J18AE046	RAMYAKRISHNA K	20	20	20	20	20	20	20	20	19	99	30
45.	15J18AE046	RAMYAKRISHNA K	20	20	20	20	20	20	20	20	19	99	30
46.	15J18AE047	RANJITH B S											
47.	15J18AE048	RAVINDRA SREE CHENDAN SAI	11			10						21	07
48.	15J18AE049	SAI KEERTHAN B L	4	18					6		20	48	15
49.	15J18AE050	SAMPRUTHA A R	20	20	20				19		19	98	30
50.	15J18AE051	SOWBHAGYA M R	20		14	17			20		20	91	28
51.	15J18AE052	SRIDHAR K R	20		12		9			8	14	63	19
52.	15J18AE053	UJWAL N				7			9		20	36	11
53.	15J18AE054	UMESH RANA	20	19	15				18		20	92	28
54.	15J18AE055	USHA G	20	19	19				15		20	93	28
55.	15J18AE056	VAISHAK M		20	20				16		20	76	23
56.	15J18AE057	VARUN M	20	20							10	50	15
57.	15J18AE058	VEERESH		15	20			19	10		10	74	23
58.	15J18AE059	VIGNESH GOWDA P		2		5			3			9	8
59.	15J18AE060	YASHWANTH R		6		4			9		20	44	14
60.	15J18AE061	YASHWANTH S	20	20					9		20	69	21
61.	15J18AE062	YASHWANTH T H	10	10	10			10	15		30	75	23
62.	15J18AE063	YOGESH E S											
63.	15J18AE064	NARINDER KUMAR	20	20	9				19		18	86	26
64.		MOHAN REDDY	10		13	6					20	55	19

B  
5/12/19

*(Signature)*  
18/12/19

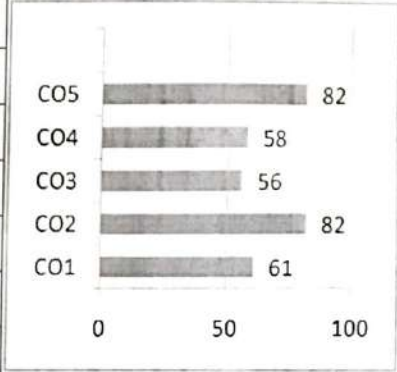
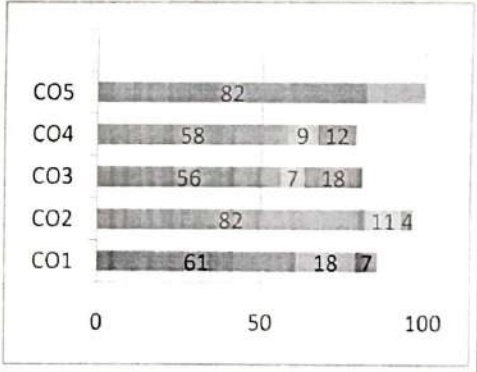
PROFESSOR & HEAD  
Department of Aeronautical Engineering  
S.J.C. Institute of Technology  
CHICKBALLAPUR-562101

SJCIT/NBA/ CO-REPT/ 2019-20		 <b>S J C INSTITUTE OF TECHNOLOGY</b> Chickballapur - 562 101 Department of Aeronautical Engineering							
Course Title		MECHANICS OF MATERIALS					Course Code	C203	
Subject Code	18AE33	Semester	3	Section	A	Emp.ID	2247		
Faculty Name		DR.BINO PRINCE RAJA D					No.students	57	
<b>CO Attainment from -TEST - 1, in the Subject: 18AE33-Based on: TYPE-1, Academic Year 2019-20</b>									
Sl.	CO Number	Sum	T_Std	Av-AT	TS(=3)	AT,%	Ac_AT	ATNT	
CO1	C204.1	129	57	2.3	35	61	1.9	YES	
CO2	C204.2	155	57	2.7	47	82	2.5	YES	
CO3	C204.3	114	57	2	32	56	1.7		
CO4	C204.4	116	57	2	33	58	1.7		
CO5	C204.5	149	57	2.6	47	82	2.5	YES	
<b>Distribution of CO Attainment from -TEST - 1, in Subj: 18AE33-Based on: TYPE-1, ACADY:2019-20</b>									
Sl.	CO Number	3	%	2	%	1	%		
CO1	C204.1	35	61	10	18	4	7		
CO2	C204.2	47	82	6	11	2	4		
CO3	C204.3	32	56	4	7	10	18		
CO4	C204.4	33	58	5	9	7	12		
CO5	C204.5	47	82	4	82		82		
<b>Remarks of Course Instructor</b>									
									
Signature of HOD/DAC				Signature of Course Instructor					

SJCIT/NBA/ CO-REPT/ 2019-20		 <b>S J C INSTITUTE OF TECHNOLOGY</b> Chickballapur - 562 101 Department of Aeronautical Engineering							
Course Title		MECHANICS OF MATERIALS					Course Code	C203	
Subject Code	18AE33	Semester	3	Section	A	Emp.ID	2247		
Faculty Name	DR.BINO PRINCE RAJA D					No.students	57		
CO Analysis from -TEST - 1, in the Subject: 18AE33-Based on: TYPE-1, Academic Year 2019-20									
Sl.	USN	Course Outcome Number			CO1	CO2	CO3	CO4	CO5
		Total Maximum Marks			100	30	40	30	30
1	1SJ18AE001	ABDUL RAHMAN J				Y		Y	
2	1SJ18AE003	AKASH M							
3	1SJ18AE004	AKASH SIDDANGOUDA PATIL				Y			Y
4	1SJ18AE006	ANNASAGARAM GOWTHAMI			Y	Y	Y	Y	Y
5	1SJ18AE007	ANUSHREE N			Y	Y	Y	Y	Y
6	1SJ18AE008	ARAVIND R NAIDU				Y	Y		Y
7	1SJ18AE009	ARJI BHARATH			Y			Y	Y
8	1SJ18AE011	BHAVANA A J			Y	Y	Y	Y	Y
9	1SJ18AE012	BINDUSHREE K				Y	Y	Y	Y
10	1SJ18AE014	CHAVALI BHIMA SANKARAM			Y	Y	Y	Y	Y
11	1SJ18AE015	CHIDANANDA			Y				Y
12	1SJ18AE016	DHANUSH KUMAR B K				Y	Y		
13	1SJ18AE017	DURGAPRASAD N S			Y	Y		Y	Y
14	1SJ18AE018	GIRIDHAR S			Y				
15	1SJ18AE019	GIRISH N			Y	Y	Y	Y	Y
16	1SJ18AE021	HARSHA D S					Y		Y
17	1SJ18AE022	HARSHITH L			Y	Y		Y	
18	1SJ18AE023	HARSHITHA K			Y	Y	Y	Y	Y
19	1SJ18AE024	HEMANTH B S			Y	Y	Y	Y	Y
20	1SJ18AE025	JANAPAREDDI SAIKUMAR				Y		Y	Y
21	1SJ18AE026	K KEERTHIVARDHAN			Y	Y	Y		Y
22	1SJ18AE027	KOLLANA YESWANTH			Y	Y		Y	Y
23	1SJ18AE028	MAHIMA T S			Y	Y		Y	Y
24	1SJ18AE029	MANIKYA G			Y	Y	Y	Y	Y
25	1SJ18AE031	MANOJ S						Y	
26	1SJ18AE032	MANOJ SINGH H			Y	Y			
27	1SJ18AE033	MARIYAMBI T S			Y	Y		Y	Y
28	1SJ18AE034	MEGHASHREE M S				Y	Y	Y	Y
29	1SJ18AE035	MOHAMMED AZAM			Y	Y	Y		Y
30	1SJ18AE036	MONIKA CHAVAN A			Y	Y	Y		Y
31	1SJ18AE037	MYTHRI C				Y	Y		Y
32	1SJ18AE038	NAGAMANI J V			Y	Y	Y		Y
33	1SJ18AE039	NAGESH D R			Y	Y	Y	Y	Y
34	1SJ18AE040	PRAJAKTA S LOKHANDE			Y				Y
35	1SJ18AE041	PRAMODGOWDA T S			Y	Y	Y	Y	Y
36	1SJ18AE042	PRASAD BELGUNDKAR			Y	Y	Y	Y	Y
37	1SJ18AE043	RACHANA J				Y			Y
38	1SJ18AE044	RAHUL P			Y	Y		Y	Y
39	1SJ18AE045	RAKESH S			Y	Y	Y	Y	
40	1SJ18AE046	RAMYAKRISHNA K			Y	Y	Y	Y	Y

SJCIT/NBA/ CO-PO-PSO REPT/ 2019-20	 <b>S J C INSTITUTE OF TECHNOLOGY</b> Chickballapur - 562 101 Department of Aeronautical Engineering						
Course Title	MECHANICS OF MATERIALS					Course Code	C203
Subject Code	18AE33	Semester	3	Section	A	Emp.ID	2247
Faculty Name	DR.BINO PRINCE RAJA D					No.students	57

**Summary of CO attainments of Sub: 18AE33 Based on (ACTUAL-TYPE-1) Academic Year:2019-20**

CO	CID_CO	CIE			SEE			CES			TOT_Attainment		
		S_AT	T_ST	ATN	S_AT	T_ST	ATN	S_AT	T_ST	ATN	ATN	%	Status
CO1	C204.1	35	57	1.8	28	57	1.5	2	40	0.2	1.5	50	NO
CO2	C204.2	47	57	2.5	28	57	1.5	1	40	0.1	1.8	59	NO
CO3	C204.3	32	57	1.7	28	57	1.5	3	40	0.3	1.5	49	NO
CO4	C204.4	33	57	1.7	28	57	1.5	4	40	0.3	1.5	49	NO
CO5	C204.5	47	57	2.5	28	57	1.5	4	40	0.3	1.8	60	YES

**Summary of PO attainments of Sub: 18AE33 Based on (ACTUAL-TYPE-1) Academic Year:2019-20**

PO Number	1	2	3	4	5	6	7	8	9	10	11	12
Direct ATNT(D)	1.74	1.74							1.74			1.74
Indirect ATNT(ID)	0.24	0.24							0.24			0.24
Total-ATNT	1.62	1.62							1.62			1.62

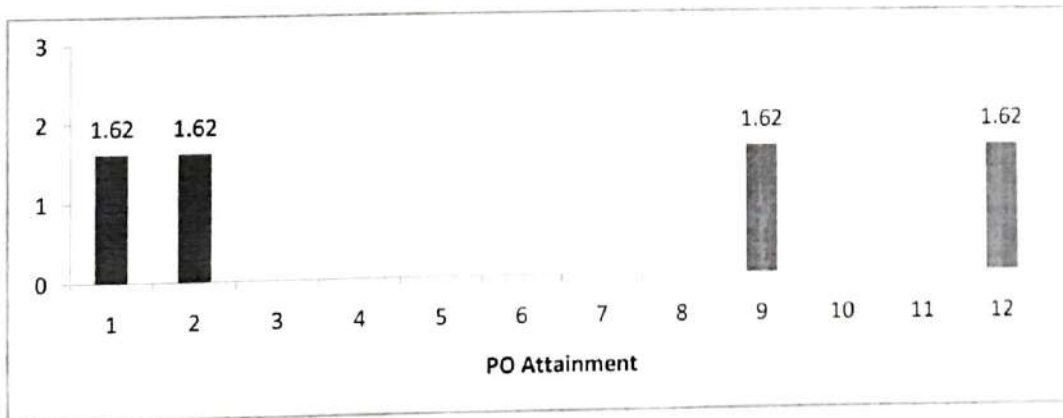

**Summary of PSO attainments in Year:2019-20**

PSO Number	1	2	3	4
Direct ATNT(D)				
Indirect ATNT(ID)				
Total-ATNT				

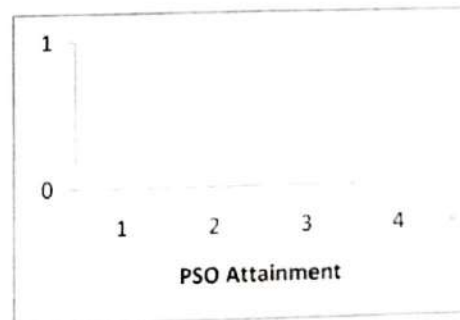

SJCIT/NBA/  
S&F-REPT/  
2019-20



**S J C INSTITUTE OF TECHNOLOGY**  
Chickballapur - 562 101  
Department of Aeronautical Engineering

<b>Course Title</b>	MECHANICS OF MATERIALS				<b>Course Code</b>	C203	
<b>Subject Code</b>	18AE33	<b>Semester</b>	3	<b>Section</b>	A	<b>Emp.ID</b>	2247
<b>Faculty Name</b>	DR.BINO PRINCE RAJA D				<b>No.students</b>	57	

Sl.	CO_ID	CO-ATTAINMENT COMPARISON FOR THE CAY, CAY-1, CAY-2		
		2019-20	2018-19	2017-18
1	C204.1	1.5	1.9	3
2	C204.2	1.8	1.88	3
3	C204.3	1.5	1.51	2.4
4	C204.4	1.5	1.515	3
5	C204.5	1.8	1.17	
6	C204.6		1.9	

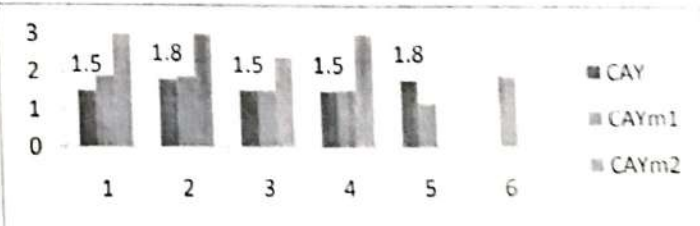

Sl.	PO-No.	PO-ATTAINMENT COMPARISON FOR THE CAY, CAY-1, CAY-2		
		2019-20	2018-19	2017-18
1	PO-1	1.62	4.18	2.35
2	PO-2	1.62	2.72	2.35
3	PO-3		2.53	2.4
4	PO-4		2.28	1.9
5	PO-5		1.33	
6	PO-6			
7	PO-7			
8	PO-8			
9	PO-9	1.62		
10	PO-10			
11	PO-11			
12	PO-12	1.62		1.9

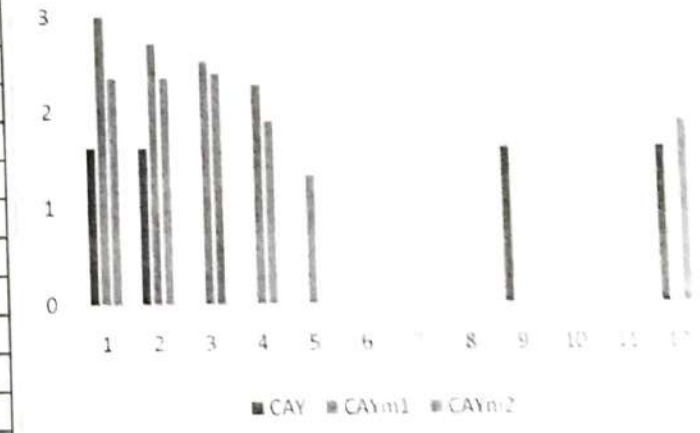

Sl.	PSO-No.	PSO-ATTAINMENT COMPARISON FOR THE CAY, CAY-1, CAY-2		
		2019-20	2018-19	2017-18
1	PSO-1			0.95
2	PSO-2			0.95
3	PSO-3			
4	PSO-4			



Academic Year	Course Instructor Name
2019-20	DR.BINO PRINCE RAJA D
2018-19	ADITYA A.R
2017-18	VIGNESWARAN CM

SJCIT/NBA/ CO-REPT/ 2019-20		 <b>S J C INSTITUTE OF TECHNOLOGY</b> Chickballapur - 562 101 Department of Aeronautical Engineering							
Course Title		MECHANICS OF MATERIALS				Course Code		C203	
Subject Code		18AE33	Semester	3	Section	A	Emp.ID		2247
Faculty Name		DR.BINO PRINCE RAJA D				No.students		57	
41	1SJ18AE048	RAVINDRA SREE CHENDAN SAI				Y			
42	1SJ18AE049	SAI KEERTHAN B L				Y		Y	
43	1SJ18AE050	SAMPRUTHA A R			Y	Y	Y	Y	Y
44	1SJ18AE051	SOWBHAGYA M R			Y	Y	Y	Y	Y
45	1SJ18AE052	SRIDHAR K R				Y			Y
46	1SJ18AE053	UJWAL N							Y
47	1SJ18AE054	UMESH RANA			Y	Y	Y	Y	Y
48	1SJ18AE055	USHA G			Y	Y	Y	Y	Y
49	1SJ18AE056	VAISHAK M				Y	Y	Y	Y
50	1SJ18AE057	VARUN M			Y	Y			Y
51	1SJ18AE058	VEERESH				Y	Y	Y	Y
52	1SJ18AE059	VIGNESH GOWDA P							
53	1SJ18AE060	YASHWANTH R			Y				Y
54	1SJ18AE061	YASHWANTH S			Y	Y			Y
55	1SJ18AE062	YASHWANTH T H				Y	Y	Y	Y
56	1SJ18AE064	NARINDER KUMAR				Y	Y	Y	Y
57	COC	MOHAN REDDY				Y	Y		Y

SJCIT/NBA/  
SEE-REPT/  
2019-20



**S J C INSTITUTE OF TECHNOLOGY**  
Chickballapur - 562 101  
Department of Aeronautical Engineering

<b>Course Title</b>	MECHANICS OF MATERIALS				<b>Course Code</b>	C203
<b>Subject Code</b>	18AE33	<b>Semester</b>	3	<b>Section</b>	A	<b>Emp.ID</b> 2247
<b>Faculty Name</b>	DR.BINO PRINCE RAJA D				<b>No.students</b>	57
<b>Result Analysis of Subject Code -18AE33 - for the Academic year 2019-20</b>						

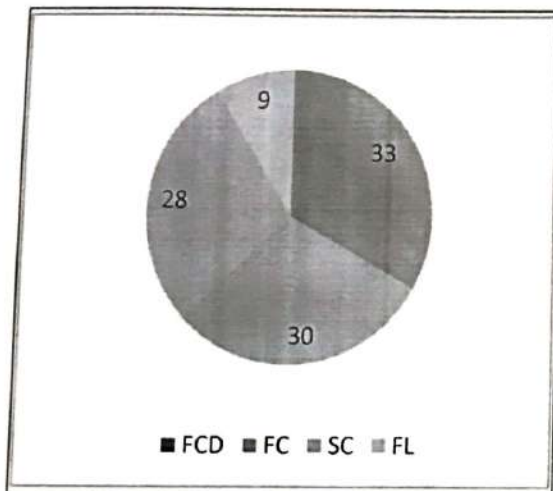

No. Students	Pass	%	Fail	%
57	52	91	5	9

No. Students	57	%	Grade Point
FCD	19	33	10,9,8
FC	17	30	7
SC	16	28	6,4
FL	5	9	0

CIE	AVG	SEE	AVG	TOT	AVG
40	32	60	33	100	65

Sum_AT	108
T_students	57
Avg.ATNT	1.9
Sum_AT(=3)	28
AT(=3)%	49
Attainment	NO

Grade Letter	S	A	B	C	D	E	F
Grade Point	10	9	8	7	6	4	0
No.of Students	2	7	10	17	15	1	1
% of Students	4	12	18	30	26	2	2

<b>CIE and SEE correlation Coefficient</b>	<b>0.72</b>
--	-------------

**Course Coordinator Remarks on Semester End Results for the Academic Year 2019-20**